

**TURCK**

Your Global Automation Partner

# TX800 HMI/PLC Series

Instructions for Use

# Table of Contents

<b>1</b>	<b>About these instructions</b>	<b>4</b>
1.1	Target groups	4
1.2	Explanation of symbols	4
1.3	Other documents	4
1.4	Feedback about these instructions	4
<b>2</b>	<b>Notes on the product</b>	<b>5</b>
2.1	Product identification	5
2.1.1	Type label	5
2.1.2	Type code	6
2.2	Scope of delivery	6
2.3	Turck service	6
<b>3</b>	<b>For your safety</b>	<b>7</b>
3.1	Intended use	7
3.2	General safety instructions	7
3.3	Notes on Ex protection	7
3.4	Note on explosion protection (USA and Canada only)	7
3.5	Conditions resulting from Ex approvals for use in Zone 2/Zone 22	8
<b>4</b>	<b>Product description</b>	<b>9</b>
4.1	Device overview	9
4.2	Properties and features	10
4.3	Functions and operating modes	10
4.3.1	Interfaces	10
4.4	Accessories	11
4.4.1	Plug-in extension modules	11
4.4.2	Power supply	11
<b>5</b>	<b>Installing</b>	<b>12</b>
5.1	Installation instructions	12
5.2	Fasten devices in the mounting cutout	13
5.3	Installing plug-in modules	13
5.4	Grounding the device	14
<b>6</b>	<b>Connecting</b>	<b>15</b>
6.1	Connecting TX805	15
6.2	Connecting TX807, TX810, TX815 and TX821	16
6.3	Connecting the device to Ethernet	16
6.4	Connecting the power supply	17
6.5	Connecting external devices to the serial interface	17
6.6	Connecting plug-in modules	18
6.6.1	Slot assignment – CAN port	19
6.6.2	Slot assignment – serial interfaces	19
<b>7</b>	<b>Commissioning</b>	<b>20</b>
7.1	Charging the battery	20
7.2	Using the touchscreen	20
7.3	Initial commissioning	20
7.3.1	User management	21

7.4	Web server login .....	21
7.5	Setting the IP address .....	22
7.5.1	Setting the IP address via the web server.....	22
7.5.2	Setting the IP address via Turck Service Tool.....	23
7.5.3	Setting the IP address via TAS (Turck Automation Suite) .....	24
7.6	Programming with CODESYS .....	26
7.6.1	Supported protocol functions .....	26
7.6.2	Access to the CODESYS WebVisu .....	26
7.7	Programming with TX VisuPro .....	26
7.7.1	Transferring TX VisuPro to the device.....	27
8	Configuring .....	28
8.1	Configuring the system settings.....	28
9	Operating.....	31
9.1	LED displays .....	31
10	Troubleshooting.....	32
11	Maintenance .....	33
12	Repair .....	33
12.1	Returning devices .....	33
13	Disposal.....	33
14	Technical data.....	34
15	Appendix: approvals and markings .....	38
16	Turck branches — contact data .....	39

# 1 About these instructions

These instructions describe the setup, functions and use of the product and help you to operate the product according to its intended purpose. Read these instructions carefully before using the product. This will prevent the risk of personal injury and damage to property. Keep these instructions safe during the service life of the product. If the product is passed on, pass on these instructions as well.

## 1.1 Target groups

These instructions are aimed at qualified personnel and must be carefully read by anyone mounting, commissioning, operating, maintaining, dismantling or disposing of the device.

When operating the device in a hazardous area, the user must have a working knowledge of explosion protection (IEC/ EN 60079-14, etc.).

## 1.2 Explanation of symbols

The following symbols are used in these instructions:



### **DANGER**

DANGER indicates a hazardous situation with a high level of risk, which, if not avoided, will result in death or serious injury.



### **WARNING**

WARNING indicates a hazardous situation with a medium level of risk, which, if not avoided, will result in death or serious injury.



### **CAUTION**

CAUTION indicates a hazardous situation with a medium level of risk, which, if not avoided, will result in moderate or minor injury.



### **NOTICE**

CAUTION indicates a situation which, if not avoided, may cause damage to property.



### **NOTE**

NOTE indicates tips, recommendations and important information about special action steps and issues. The notes simplify your work and help you to avoid additional work.



### **MANDATORY ACTION**

This symbol denotes actions that the user must carry out.



### **RESULT OF ACTION**

This symbol denotes the relevant results of an action.

## 1.3 Other documents

The following additional documents are available online at [www.turck.com](http://www.turck.com)

- Data sheet
- Quick Start Guide
- Declarations of conformity (current version)
- Approvals

## 1.4 Feedback about these instructions

We make every effort to ensure that these instructions are as informative and as clear as possible. If you have any suggestions for improving the design or if some information is missing in the document, please send your suggestions to [techdoc@turck.com](mailto:techdoc@turck.com).

## 2 Notes on the product

### 2.1 Product identification

These instructions apply to the following HMIs:

- TX805-P3CV01 (ID: 100046992),  
expected to be available from Q4/2024, not ATEX or IECEx certified, yet
- TX807-P3CV01 (ID: 100046993)
- TX810-P3CV01 (ID: 100046994)
- TX815-P3CV01 (ID: 100046995)
- TX821-P3CV01 (ID: 100046996)

#### 2.1.1 Type label

The type label is located on the back of the device.

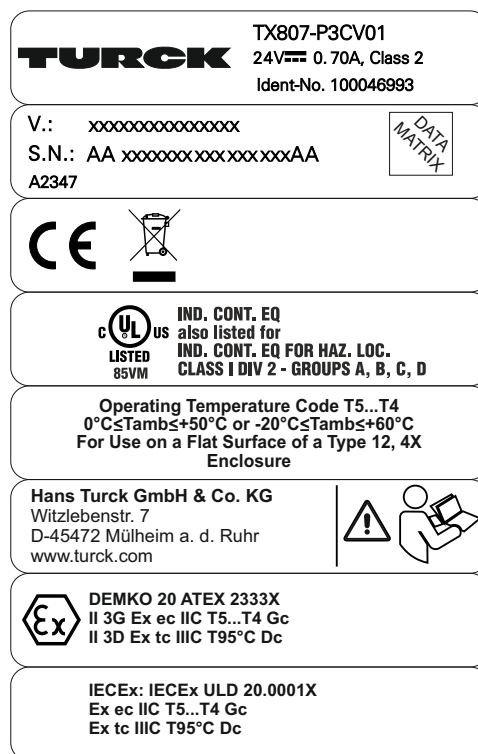

Fig. 1: Type label TX807 (example)

Type designation	TX810-...
ID	100046994
Year/week of production	A2347
Internal version ID of the product	V.: ...
Serial number	S.N.: AA...AA

## 2.1.2 Type code

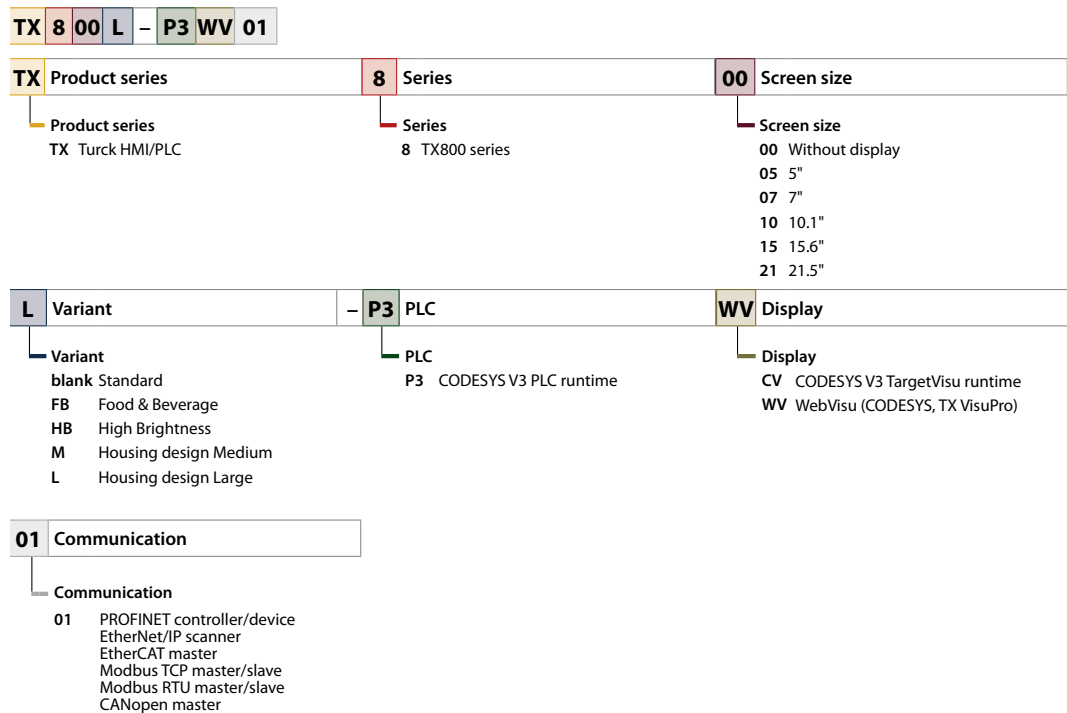

Fig. 2: Type Code TX800

## 2.2 Scope of delivery

The delivery consists of the following:

- TX800
- Power supply connector
- Connector for serial interface
- Mounting brackets
- Quick Start Guide

## 2.3 Turck service

Turck supports you in your projects – from the initial analysis right through to the commissioning of your application. The Turck product database at [www.turck.com](http://www.turck.com) offers you several software tools for programming, configuring or commissioning, as well as data sheets and CAD files in many export formats.

The contact data for Turck branches is provided at [▶ 39].

## 3 For your safety

The product is designed according to state of the art technology. Residual hazards, however, still exist. Observe the following safety instructions and warnings in order to prevent danger to persons and property. Turck accepts no liability for damage caused by failure to observe these safety instructions.

### 3.1 Intended use

The HMIs (Human Machine Interfaces) of the TX800 family are used to control, operate and monitor machine processes.

The devices are suitable for use in Zone 2 and Zone 22.

The device must only be used as described in these instructions. Any other use is not in accordance with the intended use. Turck accepts no liability for any resulting damage.

### 3.2 General safety instructions

- The device must only be fitted, installed, operated, parameterized and maintained by trained and qualified personnel.
- Only use the device in compliance with the applicable national and international regulations, standards and laws.
- The device meets the EMC requirements for the industrial areas. When used in residential areas, take measures to prevent radio frequency interference.
- The programmable devices can be used to control machines. Changes to system and network settings or the controller program may cause undefined states in the controlled machine. Changes must only be carried out if the controlled machine is in the safe stop state and the device is isolated from the machine.
- Change the default password of the integrated web server after the first login. Turck recommends the use of a secure password.

### 3.3 Notes on Ex protection

- Observe national and international regulations for explosion protection.
- When using the device in Ex areas, the user must have knowledge of explosion protection (IEC/EN 60079-14 etc.).
- Only use the device within the permissible operating and ambient conditions (see certification data and Ex approval specifications).
- Do not disconnect the device in an ignitable atmosphere when energized.
- Do not open the device when energized.
- Do not remove Ethernet connections, USB devices and SD cards in an ignitable atmosphere.
- Do not remove the battery in an ignitable atmosphere.
- Switch-off the device before replacing or wiring extension modules.

### 3.4 Note on explosion protection (USA and Canada only)

- The device is suitable for the use in Class I, Division 2, groups A, B, C and D hazardous locations or for the use in non-hazardous locations.
- The Power, input and output (I/O) wiring has to be done in accordance with Class I, Division 2 and in accordance with the authority having jurisdictions. For U.S. in accordance with Article 501.10 (B) of the National Electrical Code, NFPA 70 and for Canada in accordance with Section 18-1J2 of Canadian Electrical Code.
- Use only components that meet Class I, Division 2 certification.
- Disconnect the device from the power supply before replacing or connecting plug-in modules.
- Do not disconnect the device in an ignitable atmosphere when energized.

## 3.5 Conditions resulting from Ex approvals for use in Zone 2/Zone 22

### Special conditions of use

- Zone 2 (EPL Gc)
  - The equipment shall only be used in an area of at least pollution degree 2, as defined in IEC 60664-1.
  - The equipment shall be installed through an end-equipment enclosure that provides a minimum ingress protection of IP54 in accordance with EN IEC 60079-0, suitable for the applicable gas group, temperature classification and ambient temperature range.
  - Transient protection shall be provided that is set at a level not exceeding 140 % of the peak rated voltage value at the supply terminals to the equipment.
- Zone 22 (EPL Dc)
  - The equipment shall be installed through an end-equipment enclosure that provides a minimum ingress protection of IP6x in accordance with EN IEC 60079-0, suitable for the applicable dust group, temperature classification and ambient temperature.
- Observe the permissible ambient temperature depending on the temperature class [▶ 38].
- Care shall be taken not to allow layers of dust to form on the graphic panel in a way that might cause the accumulation of static charges.
- The devices have only been evaluated for low risk of mechanical impact.



## 4 Product description

The front of the device is designed in protection class IP66, the rear of the housing in IP20.

For the connection to Ethernet, two (TX805) or three (TX807, TX810, TX815 and TX821) Ethernet ports are available.

The serial port is used to communicate with a PLC or with field devices with RS232 or RS485 interface. Plug-in modules with different functions (digital and analog I/Os, CAN master, PROFIBUS-DP slave, RS232 and RS485 interface, mobile communication and WLAN modem, etc.) can be connected via the extension slots. A USB host port and an SD card slot are provided for using external storage media.

The TFT wide screen color display of the devices is designed as a capacitive multi-touch touch screen.

The devices all have a RISC quad-core processor (64 bit, 1.6 GHz) as well as 8 GB flash and 2 GB RAM.

### 4.1 Device overview

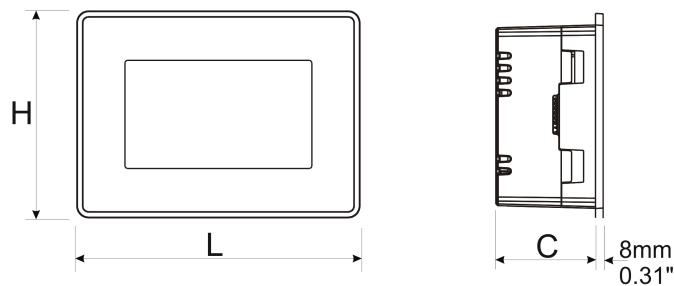

Fig. 3: Dimensions TX805

Device	Height (H)	Width (L)	Depth (C)
TX805	107 mm/4.21"	147 mm/5.78"	56 mm/2.04"

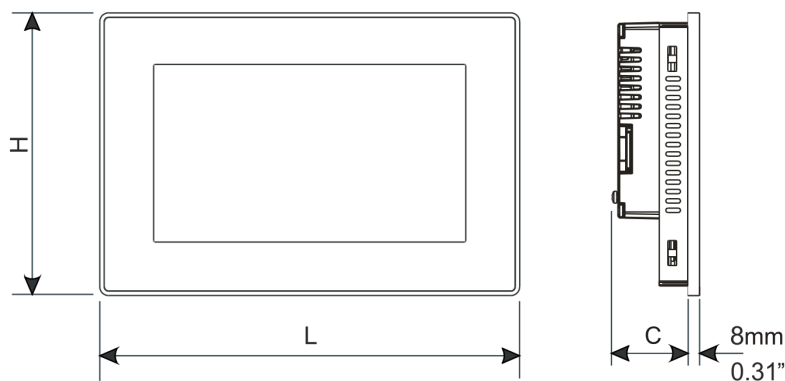

Fig. 4: Dimensions TX807, TX810, TX815 and TX821

Device	Height (H)	Width (L)	Depth (C)
TX807	147 mm/5.79"	187 mm/7.36"	47 mm/1.85"
TX810	197 mm/7.80"	282 mm/11.10"	56 mm/2.20"
TX815	267 mm/10.50"	422 mm/16.60"	56 mm/2.20"
TX821	347 mm/13.66"	552 mm/21.73"	56 mm/2.20"

## 4.2 Properties and features

- Gateway function with OPC UA Server and Client (with TX VisuPro)
- Safe connection to Turck Cloud with complete network isolation
- MQTT for connecting all common cloud systems (with TX VisuPro)
- CODESYS V3 PLC runtime with selection of the most important I/O protocols
- CODESYS V3 WebVisu or TX VisuPro WebVisu
- Optional extension modules for I/Os and further communication interfaces

## 4.3 Functions and operating modes

The CODESYS V3 PLC of the TX800 devices has the functions PROFINET controller, EtherCAT master, EtherNet/IP scanner and Modbus TCP as well as Modbus RTU client. Additionally the devices of the TX800-HMIs can be used as PROFINET device, Modbus TCP as well as Modbus RTU server.

The devices combine all functions of a PLC with the functions and interfaces of the TX VisuPro software.

### Additional functions

- Ethernet TCP/IP or UDP/IP communication
- OPC UA server (with CODESYS or TX VisuPro)
- OPC UA client and MQTT (with TX VisuPro)
- Serial communication via RS232, RS485 and RS422

### 4.3.1 Interfaces

The device has the following interfaces:

- Ethernet ports
  - TX805: 2 × 10/100 Mbit
  - TX807, TX810, TX815 and TX821: 2 × 10/100 Mbit, 1 × 10/100/1000 Mbit
- Extension slot for plug-in module
  - TX805: 1 slots for max. 2 plug-in modules
  - TX807, TX810, TX815 and TX821: 2 slots for max. 4 plug-in modules
- Serial interface
- Slot for SD card
- USB port

### Compatible SD cards

Specification	
Supported types	SD, SDHC
Format	FAT, FAT32
Max. size	Limited by FAT32 specifications ≤ 4 GB for a single file ≤ 32 GB

### Compatible USB devices

Specification	
Format	FAT, FAT32
Max. size	Limited by FAT32 specifications ≤ 4 GB for a single file ≤ 32 GB

## 4.4 Accessories

### 4.4.1 Plug-in extension modules

ID	Type	Description
6828210	TX-CAN	CAN interface
6828203	TX-IO-DX06	<ul style="list-style-type: none"> <li>■ 8 digital inputs, 24 VDC, pnp</li> <li>■ 6 digital outputs, 24 VDC, 0.5 A, pnp</li> <li>■ 1 × relay output, NO</li> </ul>
6828201	TX-IO-XX03	<ul style="list-style-type: none"> <li>■ 20 digital inputs, 24 VDC, pnp</li> <li>■ 12 digital outputs, 24 VDC, 0.5 A, pnp</li> <li>■ 8 × analog inputs, U, I, RTD, TC</li> <li>■ 4 × analog outputs, U, I</li> </ul>
100002598	TX-RS485	Serial interface for RS485/RS422 communication
100002599	TX-RS232	Serial interface for RS232 communication
100004786	TX-EXTEND	Bus extension, electromechanical adapter for the use of the plug-in module TX-IO-XX03
100025179	TX-LTE-WLAN	Wireless modem <ul style="list-style-type: none"> <li>■ Mobile radio: 2G, 3G, 4G</li> <li>■ WLAN: IEEE 802.11a, IEEE 802.11b, IEEE 802.11g 2.4 GHz and 5 GHz</li> </ul>
100010167	TX-DP-S	PROFIBUS-DP slave, 12 Mbaud

### 4.4.2 Power supply

ID	Type	Description
100002938	TX-PSC	TX power supply onnector

## 5 Installing



### NOTICE

Operation in residential and commercial areas  
**Electromagnetic disturbances!**

- ▶ When operating the devices in residential and commercial areas, observe the measured values according to IEC 61000-6-3.

The devices are inserted into a flat mounting plate with a corresponding installation cut-out.



### NOTE

The technical data in the appendix of these operating instructions contain information on the size of the required installation cut-out.

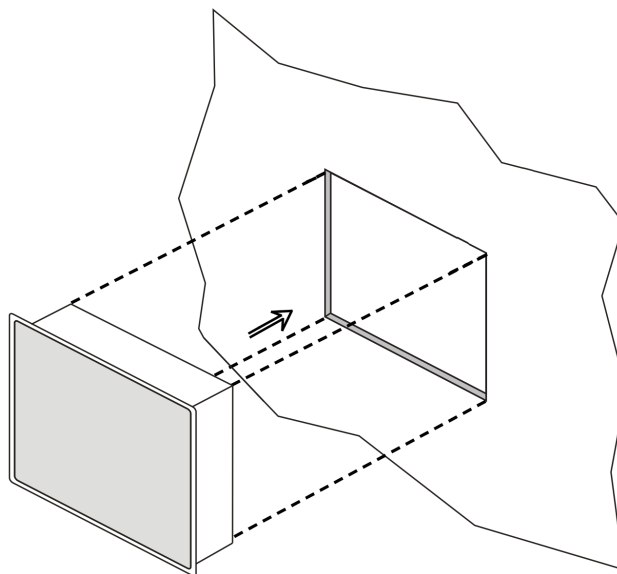

Fig. 5: TX700 – mounting

### 5.1 Installation instructions

- For use in Zone 2 and Zone 22: Observe notes on explosion protection.
- Do not cover the ventilation slots in the device.
- Do not expose the device to direct sunlight for long periods of time to avoid overheating the device.
- Do not install the device in environments where it comes into contact with corrosive chemical substances.

In order to meet the IP66, proper installation procedure must be followed:

- The device is suitable for mounting on a flat surface (curvature:  $\leq 0.5$  mm) with a thickness of 1.5...6 mm.
- The maximum surface roughness of the mounting surface is 120  $\mu\text{m}$ .
- The cut-out for the HMI must correspond to the specified dimensions, see "Technical Data".
- The borders of the cutout must be flat.
- The minimum tightening torque for the fixing screws of the holding clamps is 130 Ncm. The mounting brackets must rest firmly on the device.

## 5.2 Fasten devices in the mounting cutout

The devices are fixed in the mounting cutout with mounting brackets.

- ▶ Mount the brackets as follows.

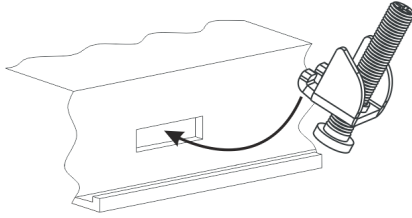

Fig. 6: Insert the brackets

- ▶ Tighten the fastening screws until the brackets are firmly in contact with the device. The minimum tightening torque to guarantee protection class IP66 is 130 Ncm.

## 5.3 Installing plug-in modules

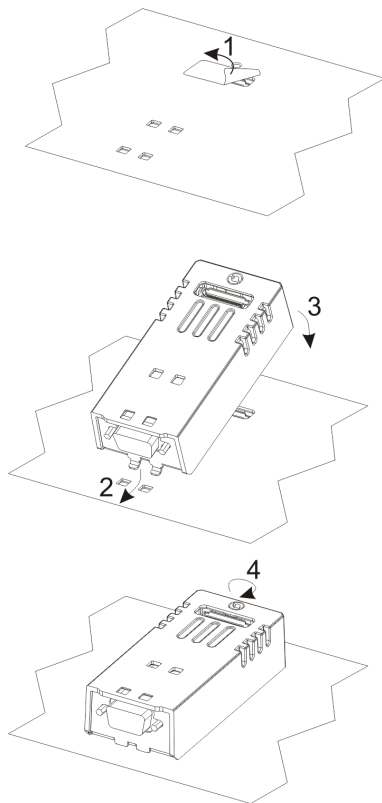

Fig. 7: Installing plug-in modules  
(e. g. TX-CAN, TX-IO-DX06)

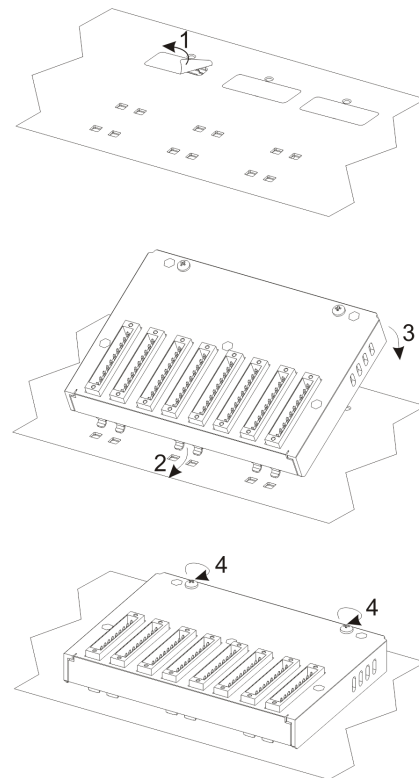

Fig. 8: Installing plug-in modules  
(e. g. TX-IO-XX03)

## 5.4 Grounding the device

The unit has to be grounded.

- ▶ Ground the device via the grounding screw on the back of the housing or via terminal 3 on the power supply connection.
- ▶ Observe the minimum cable cross-section of 1.5 mm<sup>2</sup> for the grounding connection.

General notes for device grounding

- ▶ All the electronic devices in the control system must be properly grounded.
- ▶ Carry out grounding according to the applicable regulations.
- ▶ Ground the device to minimize noise effects from electromagnetic interference.

Grounding the power supply

The power supply circuit may be floating or grounded.

- ▶ To ground the supply circuit, connect the ground wire to the protective earth as shown in the following figure (dotted line).
- ▶ If the supply circuit is not grounded, the unit itself is internally connected to ground (1 MΩ resistor with 4.7 nF capacitor connected in parallel).
- ▶ The power supply must have double or reinforced insulation.

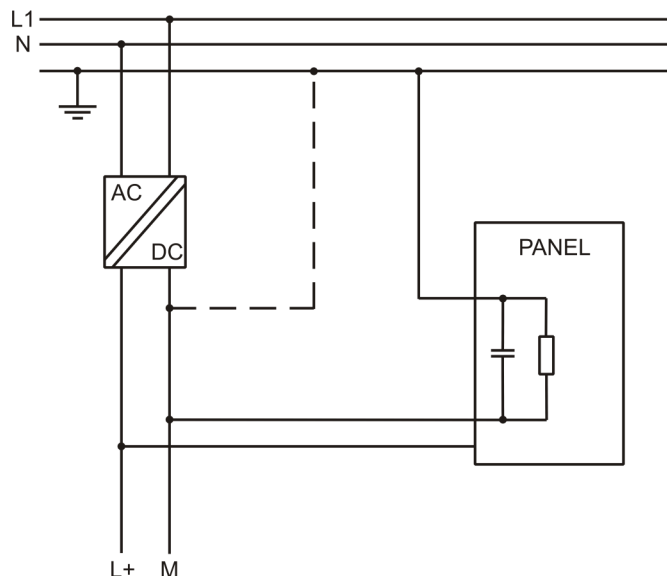

Fig. 9: Power supply – wiring

## 6 Connecting



### DANGER

Ignitable atmosphere

#### Explosion by ignitable sparks

- ▶ Do not disconnect the device in an ignitable atmosphere when energized.
- ▶ Disconnect the device from the power supply before replacing or connecting modules.

- ▶ Observe notes on explosion protection.
- ▶ Provide transient protection at the supply terminals set to a maximum of 140 % of the peak value of the rated voltage.
- ▶ Ensure that the power supply is of sufficient capacity to operate the device.

### 6.1 Connecting TX805

The device type TX805 is expected to be available from Q4/2024.

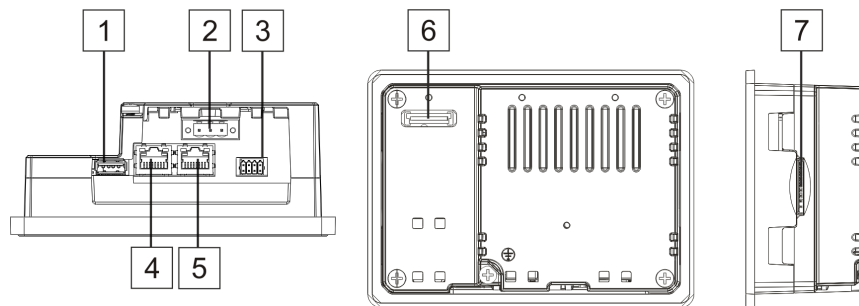

Fig. 10: Connectors TX805

Connector	Description
1	USB ports, V2.0, max. 500 mA
2	Power supply
3	Serial interface
4	Ethernet port 0 (10/100 Mbit)
5	Ethernet port 1 (10/100 Mbit)
6	Expansion slot for plug-in modules
7	SD card slot

## 6.2 Connecting TX807, TX810, TX815 and TX821

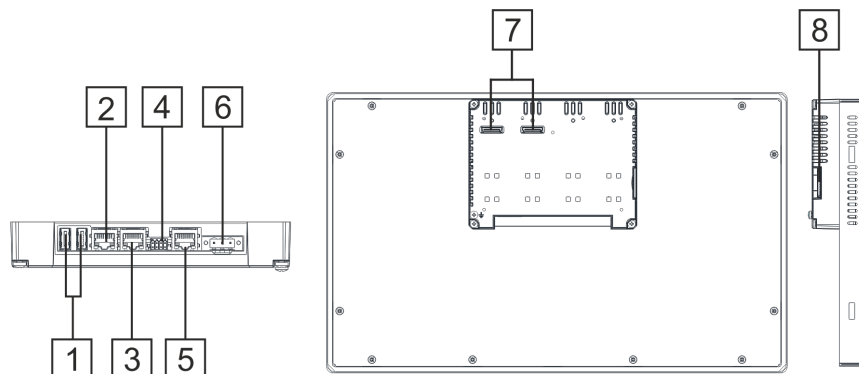

Fig. 11: Connectors TX807, TX810, TX815 and TX821

Port	Description
1	USB port, V2.0, max. 500 mA
2	Ethernet port 2 (10/100 Mbit)
3	Ethernet port 1 (10/100 Mbit)
4	Serial interface
5	Ethernet port 0 (10/100/1000 Mbit)
6	Power supply
7	2 extension slots for plug-in modules
8	SD card slot

## 6.3 Connecting the device to Ethernet

The TX805 have two RJ45 Fast Ethernet sockets for the connection to Ethernet. The TX807, TX810, TX815 and TX821 have two RJ45 Fast Ethernet sockets and one RJ45 Gigabit Ethernet socket.

- ▶ Connect the device to Ethernet using a standard Ethernet cable. Use a Gigabit-capable Ethernet cable to connect the devices to a Gigabit network.

Default settings of the Ethernet ports

ETH0/WAN:	DHCP
ETH1/LAN:	IP address: 192.168.1.254 Subnet mask: 255.255.255.0
ETH2/LAN:	DHCP (only for TX807, TX810, TX815 and TX821)



## 6.4 Connecting the power supply

- ▶ Connect the device to the voltage supply according to the following figure.

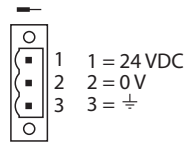

Fig. 12: Power supply connector TX...



### NOTE

The power connector is part of the scope of delivery and can be ordered as spare part [▶ 11].

## 6.5 Connecting external devices to the serial interface

The serial port is used to communicate with a PLC or with another type of device. The following standards are available at the serial interface: The type of serial interface is determined in the programming software. The connection cable must be selected to match the device to be connected.

- ▶ Connect the serial devices according to the pin assignment.

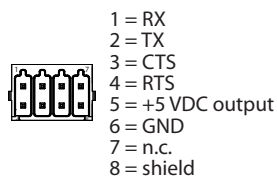

Fig. 13: RS232 connection

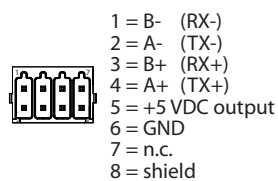

Fig. 14: RS485 connection

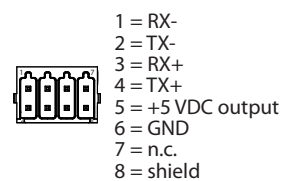

Fig. 15: RS422 connection



### NOTE

To operate in RS485, pins 1 and 2 as well as pins 3 and 4 must be connected externally.

## 6.6 Connecting plug-in modules

The TX800-HMIs allow the use of several optional in modules. Several module configurations are possible.

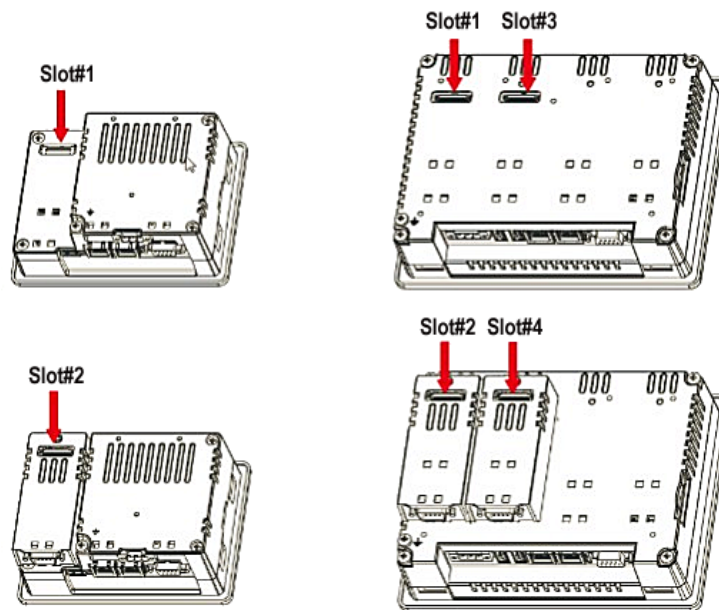

Fig. 16: Slots for plug-in modules

Slot2 and Slot4 are available only if the plug-in module has bus extension connector.

Each slot has three communication channels:

- 1 serial interface
- 1 CAN interface
- 1 SPI interface
- 1 USB interface



### NOTE

It is not possible to stack two modules that are using the same type of interface.

The following table shows, which plug-in module and how many plug-in modules can be used at which device. The column max. modules refers to the max. number of modules which can be plugged into the HMI (all slots).

Module	Application	Max. number of modules	Interface type/ communication interface	Bus extension connector
TX-CAN	CAN	■ 1 only for TX805	CAN	Yes
TX-RS485	RS485/RS422	■ 2 only for TX807, TX810, TX815 and TX821	Serial	Yes
TX-RS232	RS232		Serial	Yes
TX-IO-DX06	Compact I/O		SPI	No
TX-IO-XX03	Multifunction I/O	1 TX805: TX-EXTEND or other extension module necessary	SPI	No

Module	Application	Max. number of modules	Interface type/ communication interface	Bus extension connector
TX-DP-S	PROFIBUS-DP slave	1	SPI	No
TX-LTE- WLAN	Wireless modem		USB	Yes
TX-EXTEND	Expansion module	1 for TX805	None	Yes

The device type TX805 is expected to be available from Q4/2024.

### 6.6.1 Slot assignment – CAN port

Physical interface	CODESYS parameter „network“
Slot 1	Network 0
Slot 2	Network 0
Slot 3	Network 1
Slot 4	Network 1

### 6.6.2 Slot assignment – serial interfaces

Physical interface	CODESYS parameter “Device/Interface Parameter“	CODESYS parameter “Modbus COM/COM Port“
local serial COM port	Mode COM1	COM Port 1
Slot 1	Mode COM2	COM Port 2
Slot 2	Mode COM2	COM Port 2
Slot 3	Mode COM3	COM Port 3
Slot 4	Mode COM3	COM Port 3

Slot 1 to Slot 4 refer to the extension slots on the rear of the device.

## 7 Commissioning



### **DANGER**

Potentially explosive atmosphere

#### **Explosion due to ignitable sparks in case of electrostatic discharge**

- ▶ For use in zones 2 and 22: Clean the front of the device with a damp cloth before switching on to prevent electrostatic discharge.

### 7.1 Charging the battery

The device is equipped with a rechargeable lithium battery, which is not user replaceable.

The following information is maintained by the battery:

- Hardware real-time clock (date and time)

- ▶ Charge the battery for at least 48 hours before using the device for the first time.

When the battery is fully charged, it guarantees data backup at 25 °C for three months.

### 7.2 Using the touchscreen

- ▶ Before initial operation, check that the touch screen is working properly.
- ▶ Do not use sharp or pointed objects (screwdrivers, etc.) to operate the touch screen.

### 7.3 Initial commissioning

The Ethernet ports of the device are set to DHCP by default. During the initial commissioning, the IP address is therefore set via the system settings on the touch screen of the device, via a DHCP server in the network, via the Turck Automation Suite (TAS) or via the Turck Service Tool.

### 7.3.1 User management

To prevent unauthorized access to the system, it is necessary to enter secure passwords for the two users "user" and "admin" during initial commissioning.

Passwords must meet the following minimum requirements:

- at least 8 characters
  - at least 1 lowercase and 1 uppercase letter
  - at least 1 number
  - at least 1 special character
- ▶ Enter, confirm and save the password for the user "user".
  - ▶ Enter, confirm and save the password for the user "admin".

The screenshot shows a web browser window titled "Authentication". At the top right, there are "RELOAD" and "ADMIN" buttons. A yellow banner at the top states: "Password change is required at first access. NOTE: system will reboot upon completion". Below this, the main heading is "[1/2] Choose a password for user 'user'". On the left, there are two input fields: "New Password" and "Confirm Password", both containing masked characters. Below these fields is a "Change Password" button with a gear icon. On the right side, there is a list of password requirements: "Passwords are required to include:" followed by four bullet points: "At least 8 characters in total", "At least one lower case and one upper case letter", "At least one numeric character", and "At least one special character (eg. # ! @ ?)".

Fig. 17: Assigning admin password

- ⇒ The device performs a restart.

### 7.4 Web server login

- ▶ Open the web server using the device's IP address.
- ▶ Connect via `https://IP`.  
IP = current IP address of the TX... device
- ▶ Log on to the device as administrator:  
Default user: admin  
Default password: admin

If the simple link causes a conflict with an already active WebVisu application, the system settings can also be accessed directly via the following link:

`https://IP/machine_config`

**Example access:**

`https://192.168.1.24/machine_config`

Username: admin

Password: admin

## 7.5 Setting the IP address

### 7.5.1 Setting the IP address via the web server

- ▶ Log in to the device's web server as described under "Web server login".
- ▶ Edit the network setting via **System Settings** → **Network** → **Edit**.

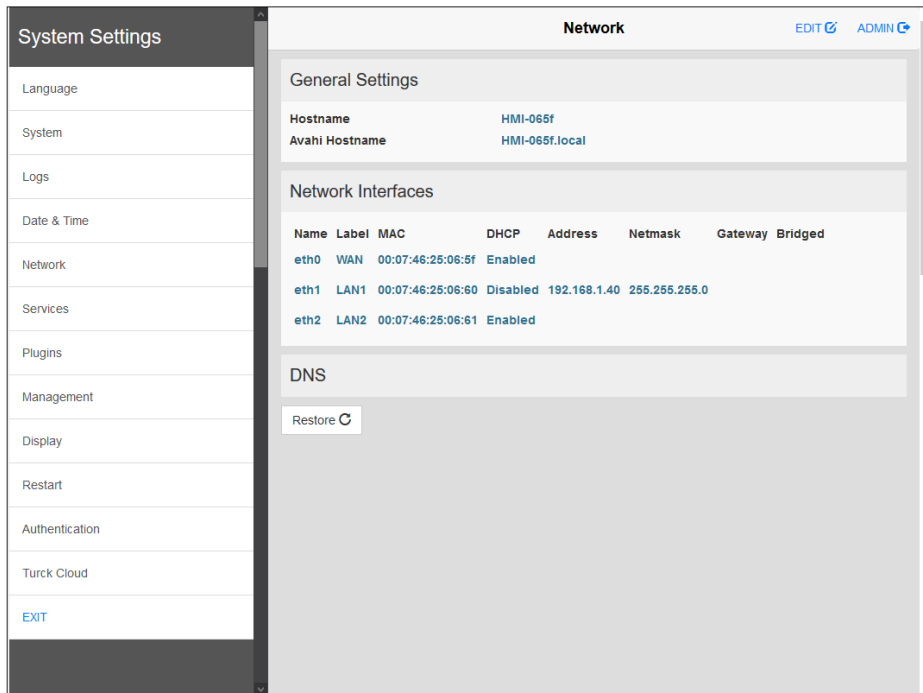

Fig. 18: Webserver – system settings

- ▶ Set the IP address, the subnet mask, etc. under **Network interface** and **save** the changes.

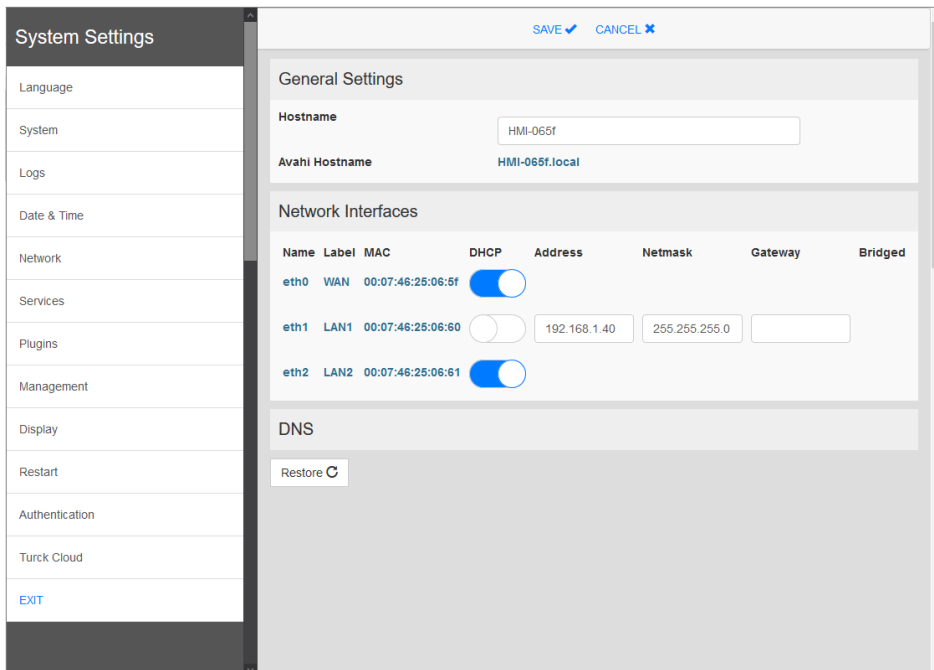

Fig. 19: Webserver – network interface

### 7.5.2 Setting the IP address via Turck Service Tool

- ▶ Connect the device to the PC via the Ethernet interface.
- ▶ Open Turck Service Tool.
- ▶ Click **Search** or press [F5].

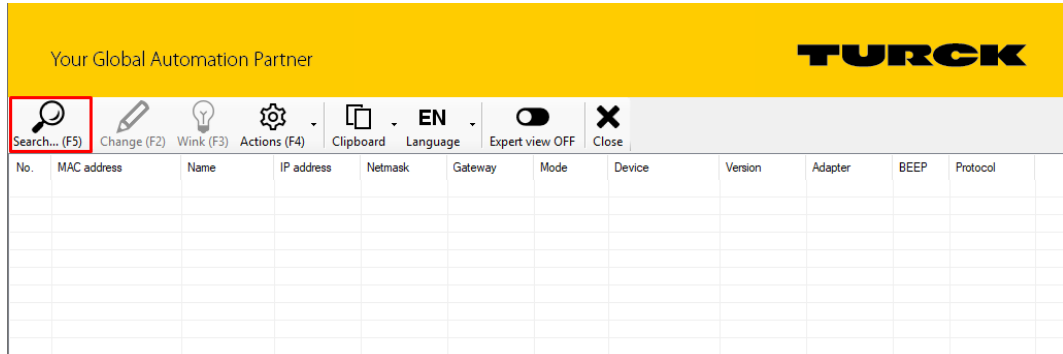

Fig. 20: Turck Service Tool – home screen

⇒ Turck Service Tool shows the connected devices.



**NOTE**

Clicking the device's IP address opens the web server.

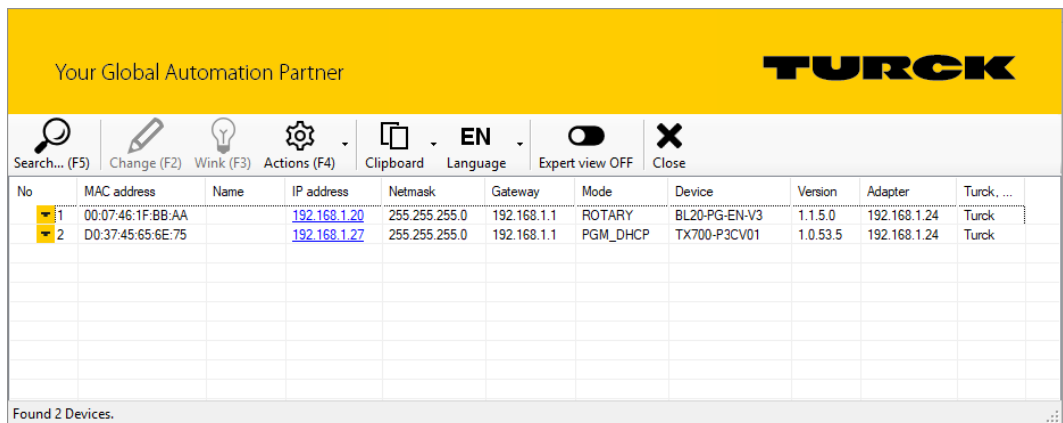

Fig. 21: Turck Service Tool – found devices

- ▶ Click on the desired device.
- ▶ Click **Change** or press [F2].
- ▶ Change the IP address and the net mask, if necessary.
- ▶ Accept the changes with **Set in device**.

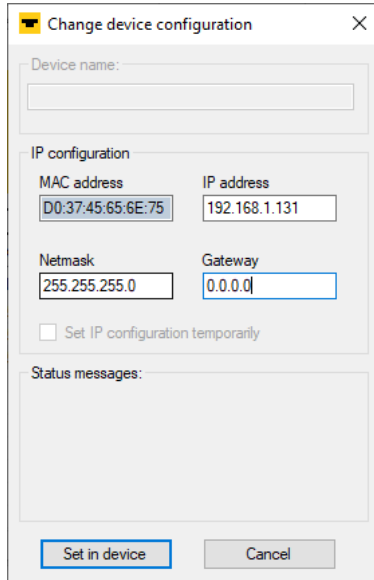

Fig. 22: Turck Service Tool – changing the IP configuration

### 7.5.3 Setting the IP address via TAS (Turck Automation Suite)

- ▶ Connect the device to the PC via the Ethernet interface.
- ▶ Open Turck Automation Suite in the web browser.
- ▶ Select **Device list** → **Network** and click **Scan network**.

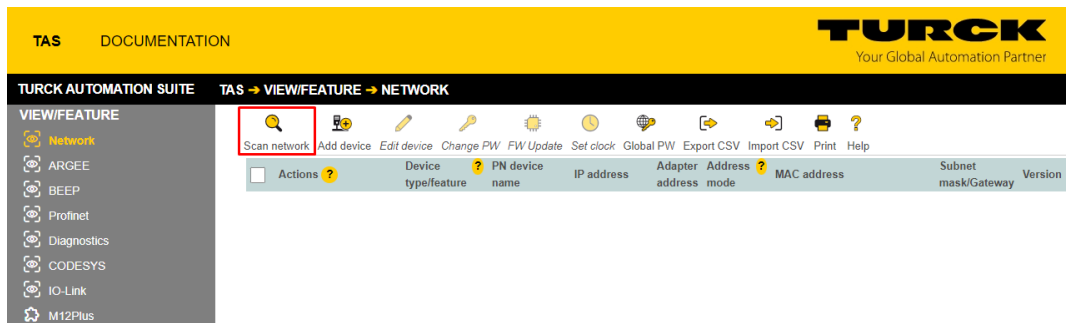

Fig. 23: Turck Automation Suite: Scan network

⇒ The Turck Automation Suite shows the connected devices.

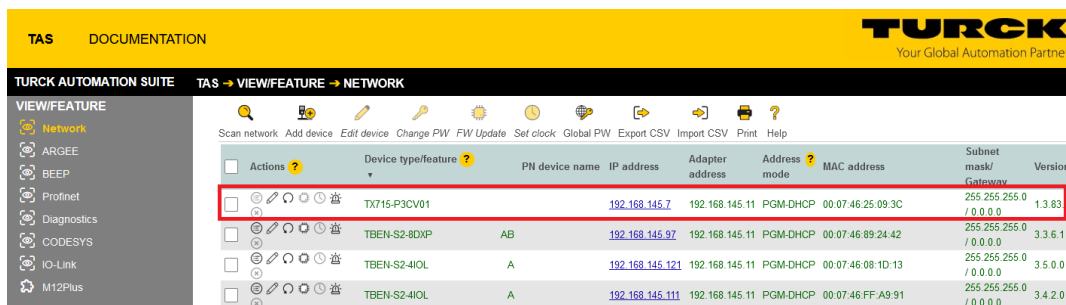

Fig. 24: Turck Automation Suite: found devices



- ▶ Click on the desired device.
- ▶ Click **Edit device**
- ▶ Change the IP address and, if necessary, the default gateway and subnet mask in the **network settings** window.
- ▶ Accept the changes with **apply**.

### Edit network settings

IP address	<input type="text" value="192.168.145.7"/>
Default gateway	<input type="text" value="0.0.0.0"/>
Subnet mask	<input type="text" value="255.255.255.0"/>

Take care, that the IP address isn't used by any other devices or switches!

Fig. 25: Turck Automation Suite: Change network settings

## 7.6 Programming with CODESYS

The devices are delivered with a pre-installed CODESYS runtime.

The CODESYS software as well as the CODESYS package for the devices can be downloaded from [www.turck.com](http://www.turck.com).

### Prerequisites

- CODESYS (≥ V 3.5.18.0) and the package "TXxxx HMI/PLC series" for the device have to be installed on a PC computer running Microsoft Windows.

### 7.6.1 Supported protocol functions

Protocol	Controller/client	Device/server
PROFINET	Yes	Yes
EtherNet/IP	Yes	-
Modbus TCP	Yes	Yes
Modbus RTU	Yes	Yes
CANopen	Yes	-
EtherCAT	Yes	-
OPC-UA	-	Yes

### 7.6.2 Access to the CODESYS WebVisu

The CODESYS WebVisu is accessed via port 8085:

<http://<<IP address>>:8085/webvisu.htm>

Example:

<http://192.168.1.40:8085/webvisu.htm>

## 7.7 Programming with TX VisuPro

### Prerequisites

- For programming the HMI/PLCs with TX VisuPro, the software tool has to be installed on a PC computer running Microsoft Windows.
- If the visualization of TX VisuPro is to be used instead of the CODESYS-TargetVisu, the TX VisuPro runtime has to be installed first.
- Before installing the TX VisuPro runtime, the existing CODESYS runtime has to be deleted.
  - ▶ To delete the currently installed runtime, run the following command:  
**System Settings** → **Management** → **Data** → **Clear**



#### NOTE

In addition to the runtime, the "delete" command also deletes all other application data such as the CODESYS application and any log files that may have been created. Alternatively, the CODESYS runtime can be deactivated in tap-tap mode. However, Turck recommends deleting the runtime completely.

### Deactivate alternative CODESYS runtime (not recommended)

- ▶ Tap-Tap-Mode [▶ 28] → **Startup sequence** → sign on as „admin“ and move **CODESYS-App** from the **Boot Sequence** area to **Installed Aps**.

### 7.7.1 Transferring TX VisuPro to the device

There are two options to transfer a TX VisuPro runtime project to a device:

- Via Ethernet
- Via a USB stick

#### Project transfer via Ethernet

- ▶ Connect the HMI device to the computer with an Ethernet network.
- ▶ Execute the command **Run/Download** in TX VisuPro. You may have to ensure that the proper firewall policy has been configured in the computer to allow TX VisuPro to access the network.

#### Project transfer via a USB stick

- ▶ Create an update package with TX VisuPro and copy it to a USB stick.

## 8 Configuring

The devices have an integrated a user interface and a web server for configuring the system. The user interface is based on HTML pages accessible via port 443 using a Web browser (Firefox V.79 Chrome V.44 or higher). Alternatively, the system settings can be called and operated via a VNC client. To use the VNC client, the VNC service must be activated in the system settings.

Initial commissioning is done by local access to the system settings via the touch screen on the device. If the "System Settings" button is not displayed on the home screen, the device must be restarted in "Tap-Tap mode" (see "Recovery operation" in "Adapting the system settings" [▶ 28]).

### 8.1 Configuring the system settings

The available options can be selected from the navigation menu on the left side of the screen.

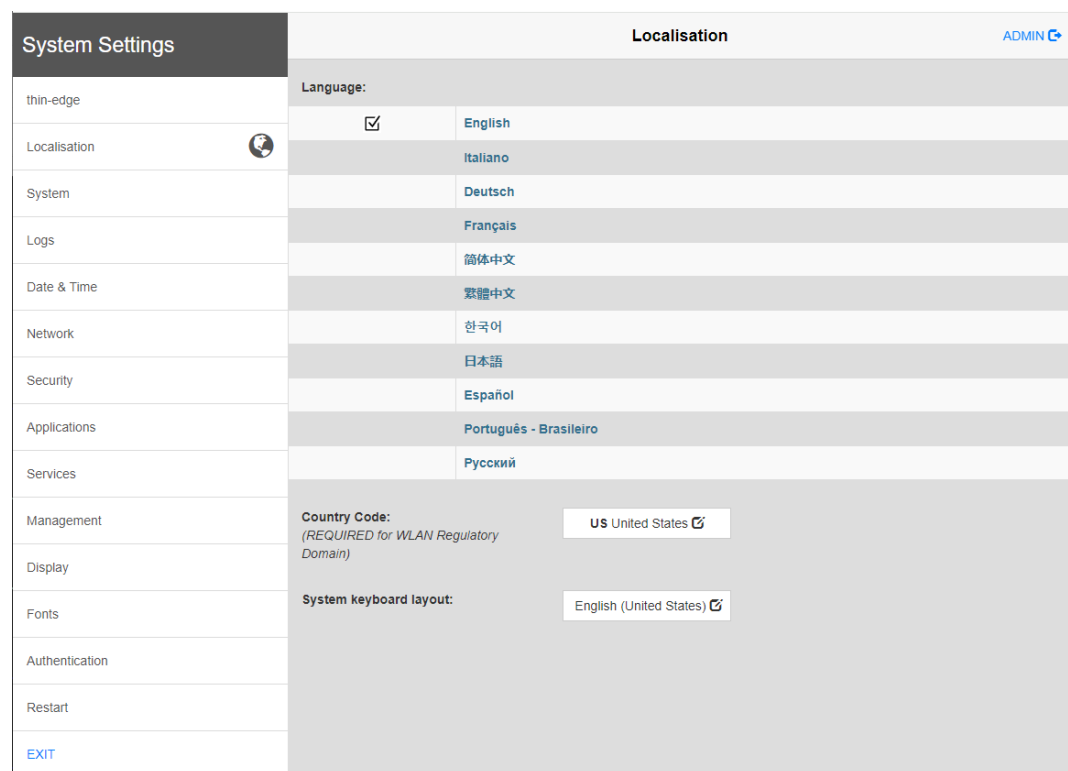

Fig. 26: System settings

System settings has two operating modes:

Mode	Usage
User mode	<ul style="list-style-type: none"> <li>■ Device with TX VisuPro runtime</li> <li>■ Device in delivery state</li> </ul>
System Mode	<p>In addition to the options in user mode, the system mode includes additional commands for system upgrade and recovery.</p> <ul style="list-style-type: none"> <li>■ Device without TX VisuPro runtime</li> <li>■ Device with software error</li> </ul>

Edit system settings in user mode

Status device	Description
Factory default status	▶ Open the <b>System Settings</b> .
TX VisuPro runtime running	▶ Press and hold the unused area of the touch screen for at least 2 s. ▶ Open the context menu and select "System Settings".

Edit the system settings in system mode

Status device	Description
Standard state	<p>If no TX VisuPro runtime is running on the device:</p> <p><b>User mode</b></p> <ul style="list-style-type: none"> <li>▶ Open the <b>System Settings</b>.</li> </ul> <p><b>System Mode</b></p> <ul style="list-style-type: none"> <li>▶ Device without TX VisuPro runtime: Restart the device via <b>Restart</b> → <b>Config. Restart OS</b>.</li> <li>▶ Device with TX VisuPro runtime: Open the context menu and select <b>System Settings</b>.</li> <li>▶ To open the context menu: Press and hold the unused area of the touch screen for at least 2 s.</li> <li>▶ Restart the device via <b>Restart</b> → <b>Config. OS</b>.</li> </ul>
Recovery operation	<p>If the device is not responsive, use the so-called "tap-tap" procedure.</p> <ul style="list-style-type: none"> <li>▶ Touch the surface of the touch screen several times with a typing frequency of at least 2 Hz immediately after switching on the device.</li> </ul> <p>⇒ When the sequence is detected, the message "Tap Tap detected, Going to Config Mode" will appear on the display.</p>

The basic settings for the device are made in the system settings.

Setting	Description
Lokalization	Configuration of the language used for the "system settings" menu.
System	Information about platform, status and timers ("like System on time, "backlight on time")
Logs	Activating and exporting persistent log for BSP
Date & Time	Date and time, including time zone and NTP Server
Network	Configuration to the IP address of the Ethernet interface and all other network settings like DNS, Gateway, DHCP, Host name, routing and bridging.
Security	Contains passwords and certificates that are required by the applications used.
Applications	Listing and managing the applications loaded on the HMI. The "App management" is used to load new applications, update or remove applications that are already installed and define the application start sequence.
Services	Activate/deactivate services (e.g. OpenSSH server, bridge, cloud, router, SNMP, logging)

Setting	Description
Management	Update of BSP components (Main OS, Config OS, Boot loader, XLoader), check for partitions consistence, update of splash screen, information about usage and size of partitions. The update of Main OS is available only in System Mode, the update of Config OS is only in User Mode.
Display	Configuring the automatic backlight, adjusting the brightness, changing the display orientation
Fonts	Shows the currently used fonts and enables the installation of user-defined fonts.
Authentication	Configuration of the password for the administrator ("admin") and for the standard user ("user"). The administrator has full access to the system settings (updates of the BSP and other system components). The standard user has some restrictions.
Restart	Restarts the device By default, the device is restarted in user mode via the "Main OS" option. The "Configuration OS" option restarts the device directly in System Settings in System Mode.

## 9 Operating



### **DANGER**

Changing components

#### **Explosion hazard – Suitability for Class I, Division 2 possibly impaired**

- ▶ When replacing components, make sure that the suitability of the device for Class I, Division 2 is not affected.
- ▶ Only use components that are suitable for use in Class I, Division 2.
- ▶ If necessary, take measures to restore suitability for Class I, Division 2.

### 9.1 LED displays

The device has the following LED displays:

- Status of the Ethernet ports

<b>LED orange (left LED)</b>	<b>Meaning</b>
Off	No Ethernet connection
On	Ethernet connection established

<b>LED green (right LED)</b>	<b>Meaning</b>
On	No data transfer
Flashing	Data transfer

## 10 Troubleshooting



### **DANGER**

Ignitable atmosphere

#### **Explosion by ignitable sparks**

- ▶ Do not disconnect the device in an ignitable atmosphere when energized.
  - ▶ Disconnect the device from the power supply before replacing or connecting modules.
- 

If the device does not function as expected, first check whether ambient interference is present. If there is no ambient interference present, check the connections of the device for faults.

If there are no faults, there is a device malfunction. In this case, decommission the device and replace it with a new device of the same type.



## 11 Maintenance

Dust layers on the display can lead to static electricity.

- ▶ To avoid dust layers on the display: Clean the device at regular intervals with a soft cloth and a neutral soap product.
- ▶ Do not use solvents.

## 12 Repair

The device must not be repaired by the user. Take defective devices out of operation and return them to Turck for an error analysis. Observe our return acceptance conditions when returning the device to Turck.

### 12.1 Returning devices

If a device has to be returned, bear in mind that only devices with a decontamination declaration will be accepted. This is available for download at

<https://www.turck.de/en/return-service-6079.php>

and must be completely filled in, and affixed securely and weather-proof to the outside of the packaging.

## 13 Disposal

The device is equipped with a rechargeable lithium battery, which is not user replaceable.

- ▶ For disposal, open the back of the device and remove the battery.



The device the lithium battery must be disposed of properly in accordance with WEEE Directive 2012/19/EU and does not belong in normal household waste.

## 14 Technical data

The device type TX805 is expected to be available from Q4/2024.

	TX805-P3CV01	TX807-P3CV01	TX810-P3CV01
<b>Device</b>			
ID	100046992	100046993	100046994
<b>Display/touch</b>			
Display	TFT color	TFT color	TFT color
Touch	Capacitive	Capacitive	Capacitive
Active image area	5"	7"	10.1"
Resolution (pixels)	800 × 480	800 × 480	1280 × 800
Format	16:9	16:9	16:9
Brightness	300 Cd/m <sup>2</sup> typ.	500 Cd/m <sup>2</sup> typ.	500 Cd/m <sup>2</sup> typ.
Dimmable	Yes (up to 0 %)	Yes (up to 0 %)	Yes (up to 0 %)
Viewing angle horizontal	■ From the right: 50° ■ From the left: 70°	70°	85°
Viewing angle vertical	70°	■ From above: 50° ■ From below: 70°	85°
<b>System</b>			
CPU	64 bit RISC, quad core, 1.6 GHz	64 bit RISC, quad core, 1.6 GHz	64 bit RISC, quad core, 1.6 GHz
Operating system	Linux RT	Linux RT	Linux RT
Flash	8 GB	8 GB	8 GB
RAM	2 GB	2 GB	2 GB
Expansion memory	USB/SD card	USB/SD card	USB/SD card
Real Time Clock	Yes (battery-backed)	Yes (battery-backed)	Yes (battery-backed)
Accuracy RTC (at 25 °C)	< 100 ppm	< 100 ppm	< 100 ppm
Buzzer	Yes	Yes	Yes
<b>SPS data</b>			
Programming	CODESYS V3	CODESYS V3	CODESYS V3
Programming languages	IEC 61131-3 (IL, LD, FBD, SFC, ST)	IEC 61131-3 (IL, LD, FBD, SFC, ST)	IEC 61131-3 (IL, LD, FBD, SFC, ST)
Programming interface	Ethernet	Ethernet	Ethernet
Program memory	20 MB	20 MB	20 MB
Non-volatile memory	63 kByte	63 kByte	63 kByte
<b>Interfaces</b>			
Ethernet ports	2 × 10/100 Mbit	1 × 10/100/1000 Mbit, 2 × 10/100 Mbit	1 × 10/100/1000 Mbit, 2 × 10/100 Mbit
Serial ports (configurable)	1 × RS232/RS485/RS422	1 × RS232/RS485/RS422	1 × RS232/RS485/RS422
USB Host port	2 × Host V2.0, max. 500 mA	2 × Host V2.0, max. 500 mA	2 × Host V2.0, max. 500 mA
SD card	Yes	Yes	Yes
Extension slot (plug-in)	1	2	2

	TX805-P3CV01	TX807-P3CV01	TX810-P3CV01
■ Max. number of plug-in modules	2	4	4
<b>Power supply</b>			
Rated value	24 VDC (SELV or Class 2)	24 VDC (SELV or Class 2)	24 VDC (SELV or Class 2)
Admissible voltage range	18...32 VDC	18...32 VDC	18...32 VDC
Current consumption at 24 VDC	0.6 A	0.7 A	1 A
<b>Dimensions</b>			
Housing (W × H)	147 × 107 mm	187 × 147 mm	282 × 197 mm
Housing (W × H)	136 × 96 mm	176 × 136 mm	271 × 186 mm
Installation depth (D)	52 cm	47 cm	56 cm
Weight	0.8 kg	1.3 kg	1.78 kg

	TX815-P3CV01	TX821-P3CV01
<b>Device</b>		
ID	100046995	100046996
<b>Display/touch</b>		
Display	TFT color	TFT color
Touch	Capacitive	Capacitive
Active image area	15.6"	21.1"
Resolution (pixels)	1366 × 768	1920 × 1080
Format	16:9	16:9
Brightness	400 Cd/m <sup>2</sup> typ.	300 Cd/m <sup>2</sup> typ.
Dimmable	Yes	Yes
Viewing angle horizontal	80°	89°
Viewing angle vertical	80°	89°
<b>System</b>		
CPU	64 bit RISC, quad core, 1.6 GHz	64 bit RISC, quad core, 1.6 GHz
Operating system	Linux RT	Linux RT
Flash	8 GB	8 GB
RAM	2 GB	2 GB
Expansion memory	USB/SD card	USB/SD card
Real Time Clock	Yes (battery-backed)	Yes (battery-backed)
Accuracy RTC (at 25 °C)	< 100 ppm	< 100 ppm
Buzzer	Yes	Yes
<b>SPS data</b>		
Programming	CODESYS V3	CODESYS V3
Programming languages	IEC 61131-3 (IL, LD, FBD, SFC, ST)	IEC 61131-3 (IL, LD, FBD, SFC, ST)
Programming interface	Ethernet	Ethernet
Program memory	20 MB	20 MB
Non-volatile memory	63 kByte	63 kByte
<b>Interfaces</b>		
Ethernet ports	1 × 10/100/1000 Mbit, 2 × 10/100 Mbit	1 × 10/100/1000 Mbit, 2 × 10/100 Mbit

	TX815-P3CV01	TX821-P3CV01
Serial ports (configurable)	1 × RS232/RS485/RS422	1 × RS232/RS485/RS422
USB Host port	2 × Host V2.0, max. 500 mA	2 × Host V2.0, max. 500 mA
SD card	Yes	Yes
Extension slot (plug-in)	2	2
■ Max. number of plug-in modules	4	4
<b>Power supply</b>		
Rated value	24 VDC (SELV or Class 2)	24 VDC (SELV or Class 2)
Admissible voltage range	18...32 VDC	18...32 VDC
Current consumption at 24 VDC	1.2 A	1.7 A
<b>Dimensions</b>		
Housing (W × H)	422 × 267 mm	552 × 347 mm
Housing (W × H)	411 × 256 mm	541 × 336 mm
Installation depth (D)	56 cm	56 cm
Weight	4.1 kg	6.1 kg



**NOTE**

For applications requiring compliance with EN 61131-2 and specifically in reference to 10 ms voltage dips, the minimum power supply voltage is 18 VDC.

**Degree of protection according to EN 60529**

Device front	IP66
Device rear	IP20

**Environmental conditions**

Operating temperature (surrounding air temperature)	-20...+60 °C (vertical installation) 0...50 °C (Temperature Class T5) installed with plug-in module TX-IO-XX03	EN 60068-2-14
Storage temperature	-30...+70 °C	EN 60068-2-1 EN 60068-2-2 EN 60068-2-14
Operating and storage humidity	5...85 % RH, non condensing	EN 60068-2-30
Vibrations	5...9 Hz, 7 mm <sub>p-p</sub> 9...150 Hz, 1 g	EN 60068-2-6
Shock	± 50 g, 11 ms, 3 pulses per axis	EN 60068-2-27

**Electromagnetic Compatibility (EMC)**

Radiation interference	Class A	CISPR 22, CISPR 16-2-3
------------------------	---------	---------------------------



**Immunity**

Electrostatic discharge	8 kV (air electrostatic discharge) 4 kV (contact electrostatic discharge)	EN 61000-4-2
-------------------------	--	--------------

<b>Electromagnetic Compatibility (EMC)</b>		
Radiation, high frequency, electromagnetic fields	80 MHz...1 GHz, 10 V/m 1.4 GHz...2 GHz, 3 V/m 2 GHz...2.7 GHz, 1 V/m	EN 61000-4-3
Burst	± 1 kV DC power port ± 1 kV signal line	EN 61000-4-4
Overvoltage	± 0,5 kV DC power port (line to earth) ± 0,5 kV DC power port (line to line) ± 1 kV signal line (line to earth)	EN 61000-4-5
Interference from high-frequency fields	0.15...80 MHz, 10 V	EN 61000-4-6
Power frequency magnetic field immunity test	Housing: 50/60 Hz, 30 A/m	EN 61000-4-8
Voltage dips, short interruptions, voltage fluctuations	Port: AC mains; Level: duration 100 % : 1 cycle and 250 cycles (50 Hz) duration 100 % : 1 cycle and 300 cycles (60 Hz) duration 40 % : 10 cycles (50 Hz) duration 40 % : 12 cycles (60 Hz) duration 70 % : 25 cycles (50 Hz) duration 70 % : 30 cycles (60 Hz) phase: 0°...180°	
Test executed on the 230 VAC side of the power supply		EN 61000-4-11
	Port: DC mains 0 %, duration: 10 ms, 20 fields × 1 s	
Test executed on the 24Vdc of the EUT		EN 61000-4-29

## 15 Appendix: approvals and markings

The ATEX or IECEx approval currently only applies to the TX807, TX810, TX815 and TX821. The TX805 (expected to be available from Q4/2024) is not ATEX or IECEx certified, yet.

Approvals	
DEMKO 20 ATEX 2333X	 II 3 G Ex ec IIC T5...T4 Gc  II 3 D Ex tc IIIC T95°C Dc
IECEx ULD 20.0001X	Ex ec IIC T5...T4 Gc Ex tc IIIC T95°C Dc

Ambient temperature  $T_{amb}$ : 0...+50 °C or -20...+60 °C,  
for mounting on the flat surface of a housing of type 12, 4X

Max. ambient temperature	Temperature Class
-20...+60 °C	T4
0...+50 °C	T5

Approvals	
	see Declarations of conformity (current version)
cULus	File No. E484727 File No. E484803 Class I, Division 2, Groups A, B, C and D
DNV	TAA000027Z

## 16 Turck branches — contact data

<b>Germany</b>	Hans Turck GmbH & Co. KG Witzlebenstraße 7, 45472 Mülheim an der Ruhr <a href="http://www.turck.de">www.turck.de</a>
<b>Australia</b>	Turck Australia Pty Ltd Building 4, 19-25 Duerdin Street, Notting Hill, 3168 Victoria <a href="http://www.turck.com.au">www.turck.com.au</a>
<b>Austria</b>	Turck GmbH Graumanngasse 7/A5-1, A-1150 Vienna <a href="http://www.turck.at">www.turck.at</a>
<b>Belgium</b>	TURCK MULTIPROX Lion d'Orweg 12, B-9300 Aalst <a href="http://www.multiprox.be">www.multiprox.be</a>
<b>Brazil</b>	Turck do Brasil Automação Ltda. Rua Anjo Custódio Nr. 42, Jardim Anália Franco, CEP 03358-040 São Paulo <a href="http://www.turck.com.br">www.turck.com.br</a>
<b>Canada</b>	Turck Canada Inc. 140 Duffield Drive, CDN-Markham, Ontario L6G 1B5 <a href="http://www.turck.ca">www.turck.ca</a>
<b>China</b>	Turck (Tianjin) Sensor Co. Ltd. 18,4th Xinghuazhi Road, Xiqing Economic Development Area, 300381 Tianjin <a href="http://www.turck.com.cn">www.turck.com.cn</a>
<b>Czech Republic</b>	TURCK s.r.o. Na Brne 2065, CZ-500 06 Hradec Králové <a href="http://www.turck.cz">www.turck.cz</a>
<b>France</b>	TURCK BANNER S.A.S. 11 rue de Courtalin Bat C, Magny Le Hongre, F-77703 MARNE LA VALLEE Cedex 4 <a href="http://www.turckbanner.fr">www.turckbanner.fr</a>
<b>Hungary</b>	TURCK Hungary kft. Árpád fejedelem útja 26-28., Óbuda Gate, 2. em., H-1023 Budapest <a href="http://www.turck.hu">www.turck.hu</a>
<b>India</b>	TURCK India Automation Pvt. Ltd. 401-403 Aurum Avenue, Survey. No 109 /4, Near Cummins Complex, Baner-Balewadi Link Rd., 411045 Pune - Maharashtra <a href="http://www.turck.co.in">www.turck.co.in</a>
<b>Italy</b>	TURCK BANNER S.R.L. Via San Domenico 5, IT-20008 Bareggio (MI) <a href="http://www.turckbanner.it">www.turckbanner.it</a>
<b>Japan</b>	TURCK Japan Corporation ISM Akihabara 1F, 1-24-2, Taito, Taito-ku, 110-0016 Tokyo <a href="http://www.turck.jp">www.turck.jp</a>

<b>Korea</b>	Turck Korea Co, Ltd. A605, 43, Iljik-ro, Gwangmyeong-si 14353 Gyeonggi-do <a href="http://www.turck.kr">www.turck.kr</a>
<b>Malaysia</b>	Turck Banner Malaysia Sdn Bhd Unit A-23A-08, Tower A, Pinnacle Petaling Jaya, Jalan Utara C, 46200 Petaling Jaya Selangor <a href="http://www.turckbanner.my">www.turckbanner.my</a>
<b>Mexico</b>	Turck Comercial, S. de RL de CV Blvd. Campestre No. 100, Parque Industrial SERVER, C.P. 25350 Arteaga, Coahuila <a href="http://www.turck.com.mx">www.turck.com.mx</a>
<b>Netherlands</b>	Turck B. V. Ruiterlaan 7, NL-8019 BN Zwolle <a href="http://www.turck.nl">www.turck.nl</a>
<b>Poland</b>	TURCK sp.z.o.o. Wroclawska 115, PL-45-836 Opole <a href="http://www.turck.pl">www.turck.pl</a>
<b>Romania</b>	Turck Automation Romania SRL Str. Siriului nr. 6-8, Sector 1, RO-014354 Bucuresti <a href="http://www.turck.ro">www.turck.ro</a>
<b>Sweden</b>	Turck AB Fabriksstråket 9, 433 76 Jonsered <a href="http://www.turck.se">www.turck.se</a>
<b>Singapore</b>	TURCK BANNER Singapore Pte. Ltd. 25 International Business Park, #04-75/77 (West Wing) German Centre, 609916 Singapore <a href="http://www.turckbanner.sg">www.turckbanner.sg</a>
<b>South Africa</b>	Turck Banner (Pty) Ltd Boeing Road East, Bedfordview, ZA-2007 Johannesburg <a href="http://www.turckbanner.co.za">www.turckbanner.co.za</a>
<b>Turkey</b>	Turck Otomasyon Ticaret Limited Sirketi Inönü mah. Kayisdagi c., Yesil Konak Evleri No: 178, A Blok D:4, 34755 Kadiköy/ Istanbul <a href="http://www.turck.com.tr">www.turck.com.tr</a>
<b>United Kingdom</b>	TURCK BANNER LIMITED Blenheim House, Hurrricane Way, GB-SS11 8YT Wickford, Essex <a href="http://www.turckbanner.co.uk">www.turckbanner.co.uk</a>
<b>USA</b>	Turck Inc. 3000 Campus Drive, USA-MN 55441 Minneapolis <a href="http://www.turck.us">www.turck.us</a>



# TURCK

Your Global Automation Partner

Over 30 subsidiaries and  
60 representations worldwide!

100048212 | 2024/03



[www.turck.com](http://www.turck.com)