











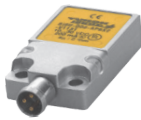







# Rectangular Inductive Sensor Selection Guide

Rectangular Style Sensors					
					
Housing	4.7 mm	5.5 mm	6 mm	8 mm	10 mm
Sensing Range	2 mm	2 - 3.5 mm	3 mm	5 - 8 mm	2 - 5 mm
Pages	A11	A11	A11	A13 - 16	A17
Features				Uprox+	Uprox+

Rectangular Style Sensors					
					
Housing	Variable, with pigtail	10 mm	12 mm	14 mm	20 mm
Sensing Range	2 - 7 mm	2 - 4 mm	2 - 5 mm	10 - 20 mm	15 - 25 mm
Pages	A19	A21	A23	A25	A27 - 30
Features			Uprox+		

Rectangular Style Sensors					
					
Housing	18 mm	25 mm	30 mm	40 mm	40 mm
Sensing Range	5 - 10 mm	10 mm	15 mm	20 mm	15 - 50 mm
Pages	A31	A31	A31	A33	A35 - 40
Features				Uprox+	Uprox+

Rectangular Style Sensors					
					
Housing	40 mm	80 mm	80 mm	90 mm	Variable
Sensing Range	15 - 50 mm	40 - 75 mm	50 - 75 mm	60 - 100 mm	2 - 50 mm
Pages	A41 - 46	A47 - 50	A51	A53	A55 - 58
Features	Uprox+	Uprox+	Uprox+		Intrinsically Safe

We reserve the right to make technical alterations without prior notice.

## Rectangular Inductive Sensor Part Number Key



- Mounting**  
 B = embeddable  
 N = nonembeddable
- Principle of Operation**  
 i = inductive
- Rated Operating Distance (mm)**
- Sensing Characteristics**  
 S = side sensing on Q10S sensor  
 U = Uprox® Sensor
- Housing Style**  
**Rectangular**  
 K = smooth  
 Q = metal or plastic, various rectangular styles
- Limit Switch**  
 CA = Stubby®, short aluminum housing, connector  
 CK = Stubby, short plastic housing, connector  
 CP = Combiprox®, plastic housing, terminal chamber base with removable sensor
- Housing Height (mm)**

- Number of LEDs**  
 (blank) = no LEDs  
 X = 1 LED  
 X2 = 2 LEDs
- Voltage Range**  
**AC/DC: (No SCP\*\*)**  
 3 = 20-250 VAC, 10-300 VDC  
 31 = 20-250 VAC, 10-300 VDC, plastic barrel  
**AC/DC: (Latched SCP)**  
 30 = 20-250 VAC, 10-300 VDC 400 mA  
 32 = 20-250 VAC, 10-300 VDC 400 mA  
**DC:**  
 4 = 10-65 VDC, polarity protected, pulsed SCP\*\*  
 6 = 10-30 VDC, polarity protected, pulsed SCP  
 \*\*SCP = short-circuit and overload protection
- Output**  
 D = 2-wire DC (transistor output)  
 DZ = 2-wire AC/DC, (power MOSFET output)  
 N = NPN transistor (current sinking)  
 P = PNP transistor (current sourcing)  
 Z = 2-wire AC or 2-wire AC/DC
- Output Function**  
 A = normally open (N.O.)  
 F = connection programmable (N.O. or N.C.)  
 V = complementary outputs: one N.O., one N.C.  
 Y0 = NAMUR output, requires switching amplifier  
 Y1 = NAMUR output, requires switching amplifier/ATEX approved

- Secondary Housing Modifier**  
 SR = straight terminal chamber

**NOTE:**  
 Part number keys are to assist in identification only.  
 Verify new part numbers with factory; some configurations are not possible.

We reserve the right to make technical alterations without prior notice.

Rectangular Inductive Sensors

### Wiring Options\*

#### A. Connectorized Sensor

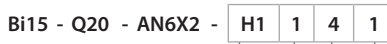

- Connector Family**  
 B1 = Minifast®, Metal, Male  
 B2 = Minifast, Plastic, Male  
 B3 = Microfast®, Metal, Male  
 H1 = Eurofast®, Metal or Plastic, Male  
 V1 = Picofast®, Metal, Male  
 V2 = Picofast, Snap and M8x1, Male (Q08 Only)
- Connector/Sensor Transition**  
 1 = straight

- Wiring Configuration**  
**Example:**  
 1 = Standard  
 3 = N.C. DC Output on Pin 4 (for US)
- Number of Pins**

#### B. Potted Cable

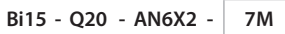

- Cable Length**  
 Blank = 2 meter cable  
 7M = 7 meter cable

### Special Option Codes\*\*



- Option Code**  
**Example:**  
 /S34 = Weld Field Immune  
 /S97 = -40 °C (-40 °F) Operating Temperature  
 /S100 = +100 °C (+212 °F) Operating Temperature  
 /S1590 = CK/CA40 sensors with Weldguard laminate  
 /S1591 = CA40 sensors with Weldguard and Armorguard

# Rectangular Inductive Sensors

## Mounting

Turck inductive proximity sensors are manufactured with a shielded coil, designated by “Bi” in the part number, and a nonshielded coil, designated by “Ni” in the part number (see page A2). Embeddable (shielded) units may be safely flush-mounted in metal. Nonembeddable (nonshielded) units require a metal free area around the sensing face. Because of possible interference of the electromagnetic fields generated by the oscillators, minimum spacing is required between adjacent or opposing sensors.

It is good engineering practice to mount sensors horizontally or with the sensing face looking down. Avoid sensors that look up wherever possible, especially if metal filings and chips are present.

## Embeddable Mounting Characteristics - Rectangular Housings

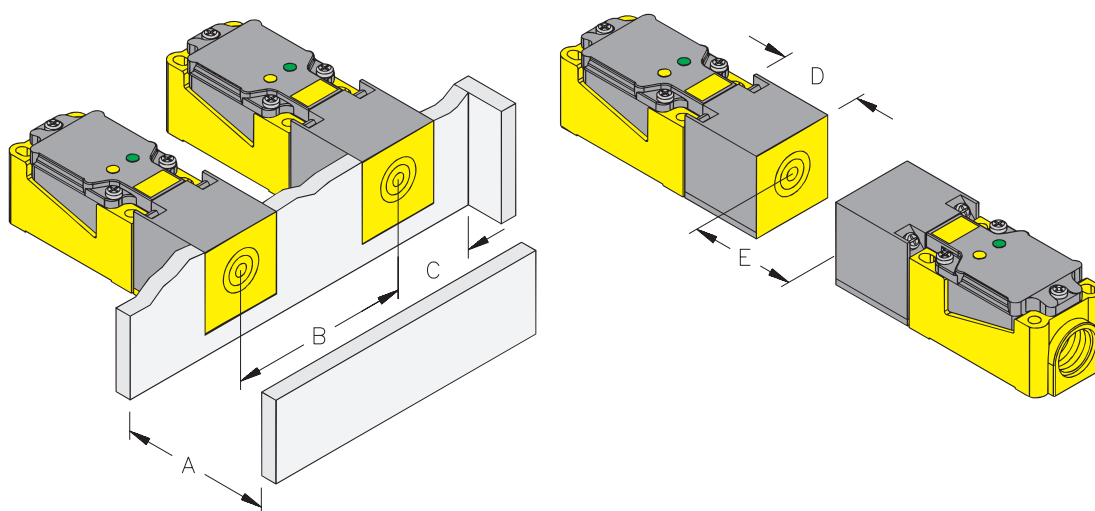

## Flush Mountable - CK40 and CP40

Housing Type	Sensor Type	A	B	C	D	E
CP40/CK40	Bi15U	45.00	80.00	40.00	40.00	90.00
CP40/CK40	Bi15	45.00	80.00	40.00	40.00	90.00
CP40/CK40/CA40	Bi20U	60.00	80.00	40.00	40.00	120.00
CP40	Bi20	60.00	80.00	40.00	40.00	120.00
CP40/CK40	Bi30U	90.00	80.00	40.00	40.00	180.00

Dimensions are in mm.

We reserve the right to make technical alterations without prior notice.

## Rectangular Inductive Sensors

### Nonembeddable Mounting Characteristics - Rectangular Housings

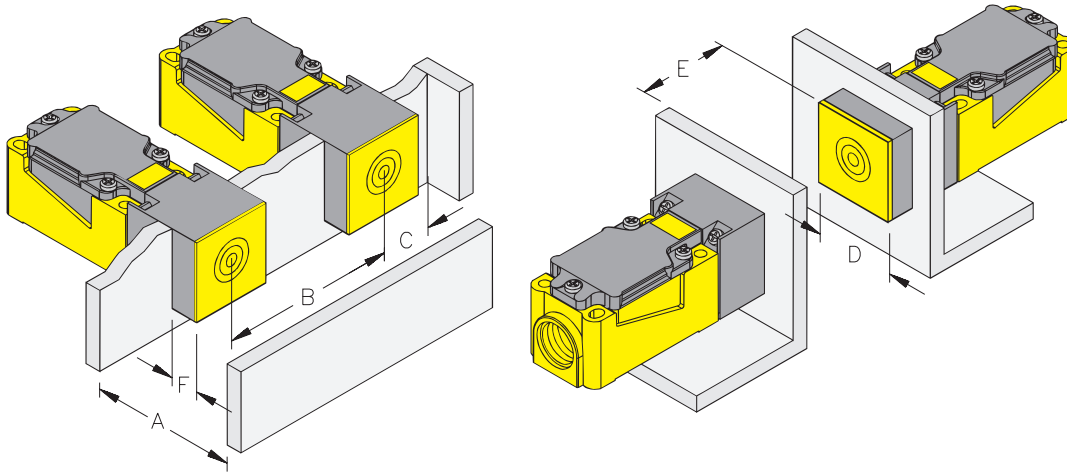

### Non - Flush Mountable - CA25, CK40, and CP40

Housing Type	Sensor Type	A	B	C	D	E	F	1-Side	2-Side	3-Side	4-Side
CP/CK40	Ni20	60.00	120.00	60.00	40.00	120.00	20.00				
CP/CK40	Ni25U	75.00	240.00	60.00	40.00	150.00	30.00	Sr=22 mm*	Sr=20 mm*	Sr=17 mm*	Sr=13 mm*
CP/CK40	Ni25	75.00	120.00	60.00	40.00	150.00	40.00				
CP/CK40	Ni35U	105.00	240.00	60.00	40.00	210.00	30.00	Sr=28 mm*	Sr=24 mm*	Sr=19 mm*	
CP/CK40	Ni35	105.00	180.00	60.00	40.00	210.00	40.00				
CP/CK40	Ni40U	120.00	240.00	60.00	40.00	240.00	30.00				
CP/CK40	Ni40	120.00	180.00	60.00	40.00	240.00	40.00				
CP/CK40	Ni50U	105.00	240.00	60.00	40.00	240.00	30.00	Sr=35 mm*	Sr=25 mm*	Sr=20 mm*	Sr=15 mm*

Dimensions are in mm.

\*Uprox Non-embeddable flush mounting guidelines. The above Uprox Ni sensors with DC outputs can be flush mounted because the sensor automatically compensates for metal alongside its sensing face by decreasing the sensing range, preventing the output from locking on.

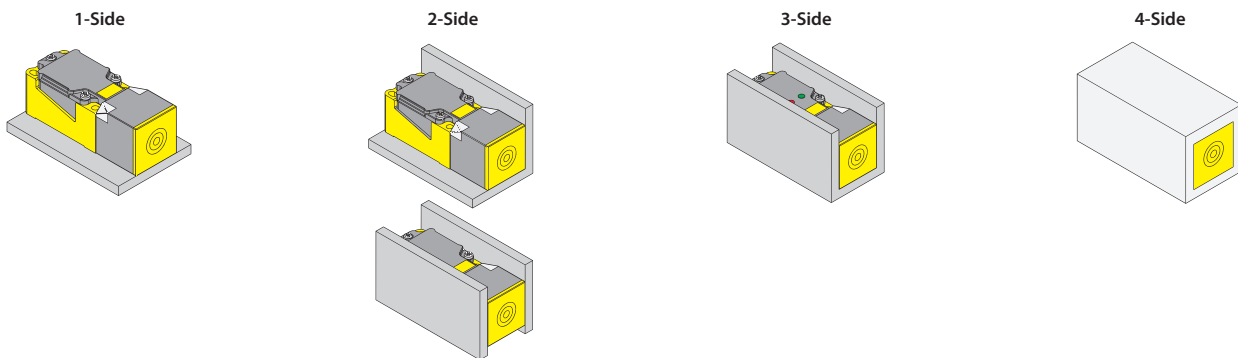

We reserve the right to make technical alterations without prior notice.

Rectangular Inductive Sensors

# Rectangular Inductive Sensors

## Embeddable Mounting Characteristics - Rectangular Housings

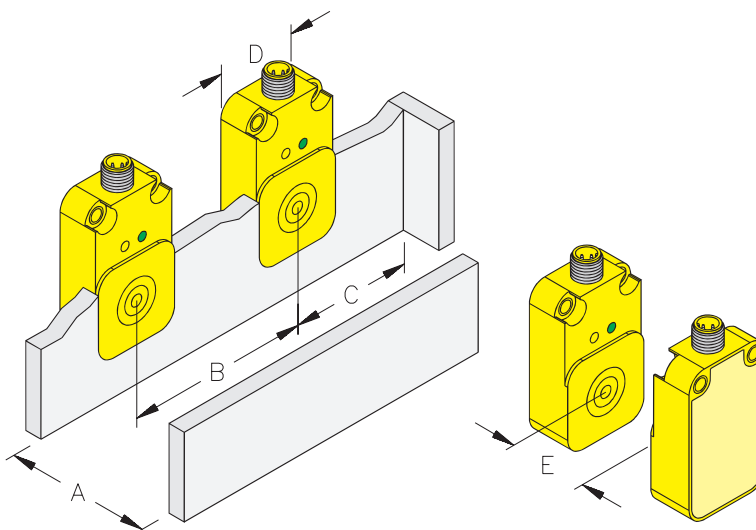

### Flush Mountable

Housing Type	Sensor Type	A	B	C	D	E
Q4.7	Bi2	6.00	16.00	12.00	8.00	12.00
Q5.5	Bi2	6.00	16.00	8.00	8.00	12.00
Q06	Bi3	9.00	35.00	17.00	17.30	18.00
Q08	Bi5	15.00	40.00	20.00	20.00	30.00
Q08	Bi5U	15.00	40.00	20.00	20.00	30.00
Q08	Bi7	21.00	40.00	20.00	20.00	42.00
Q10	Bi8	24.00	50.00	25.00	25.00	48.00
Q10	Bi8U	24.00	50.00	25.00	25.00	48.00
Q14	Bi10	30.00	45.00	30.00	30.00	60.00
Q14	Bi10U	30.00	45.00	30.00	30.00	60.00
Q20	Bi15	45.00	60.00	40.00	40.00	90.00
Q20	Bi15U	45.00	60.00	40.00	40.00	90.00
CP80	Bi40	120.00	160.00	80.00	80.00	240.00
Q80	Bi50U	150.00	240.00	80.00	80.00	300.00

Dimensions are in mm.

We reserve the right to make technical alterations without prior notice.

## Rectangular Inductive Sensors

### Embeddable Mounting Characteristics - Rectangular Housings

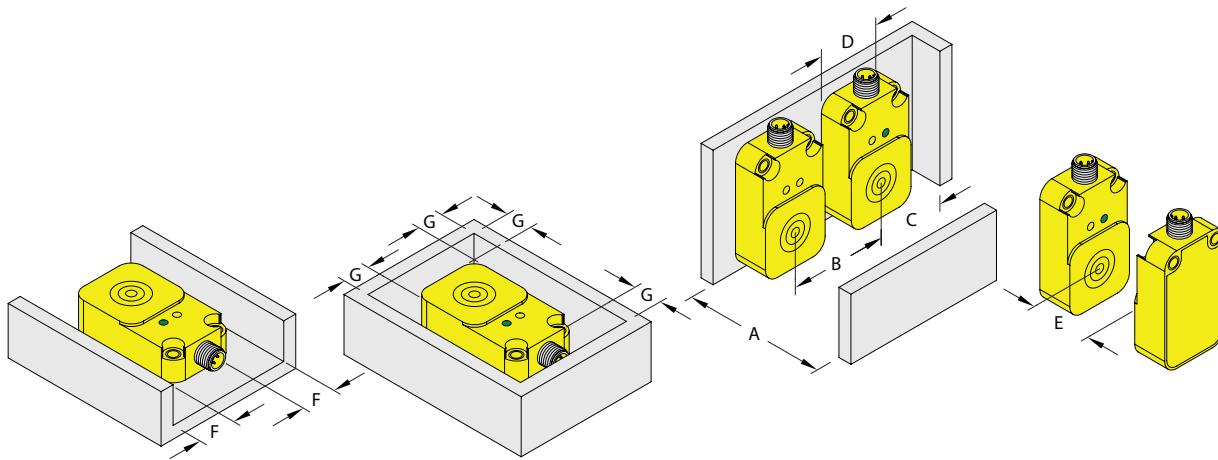

### Non-flush Mountable - Minimum Distances - Q5.5, Q14, Q20, CP80, Q80 and K90

Housing Type	Sensor Type	A	B	C	D	E	F	G	1-Side	2-Side	3 & 4-Side
Q5.5	Ni3.5	11.00	24.00	12.00	8.00	21.00	4.00	8.00			
Q14	Ni20	60.00	90.00	45.00	30.00	120.00	20.00	40.00			
Q20	Ni25	75.00	120.00	60.00	40.00	150.00	25.00	50.00			
CP80	Ni40	120.00	240.00	120.00	80.00	240.00	80.00	80.00			
Q80	Ni75U	225.00	240.00	60.00	80.00	450.00	80.00	80.00	Sr=50 mm*	Sr=45 mm*	Sr=40 mm*
CP80	Ni75U	225.00	240.00	120.00	80.00	450.00	80.00	80.00			
K90	Ni60	180.00	270.00	135.00	90.00	360.00	60.00	90.00			
K90SR	Ni100U	300.00	270.00	90.00	90.00	600.00	100.00	200.00	Sr=70 mm*		

Dimensions are in mm.

\*Uprox Non-embeddable flush mounting guidelines. The above Uprox Ni sensors with DC outputs can be flush mounted because the sensor automatically compensates for metal alongside its sensing face by decreasing the sensing range, preventing the output from locking on.

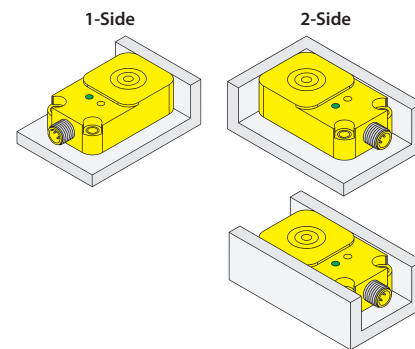

We reserve the right to make technical alterations without prior notice.

Rectangular Inductive Sensors

# Rectangular Inductive Sensors

## Embeddable Mounting Characteristics

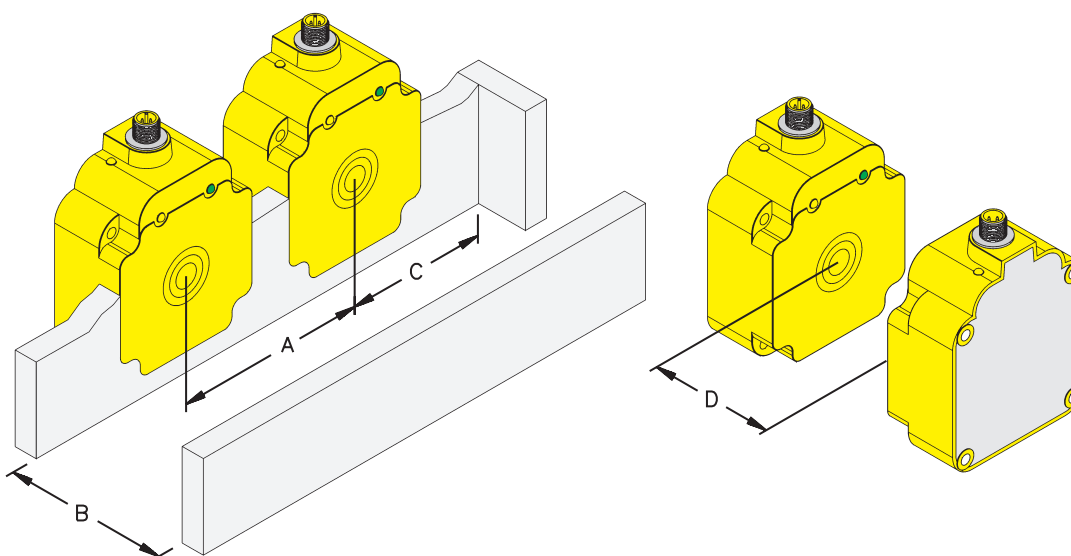

### Embeddable, Square Sensors

Part Number	A	B	C	D
Bi50U-Q80	240.00	150.00	80.00	300.00

Dimensions are in mm.

## Nonembeddable Mounting Characteristics

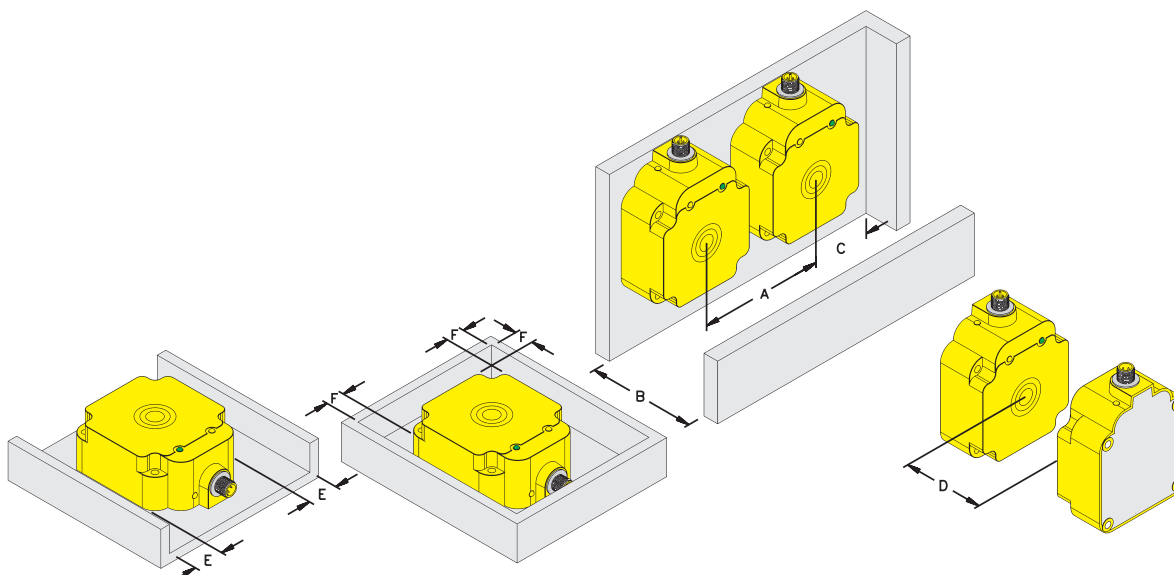

### Nonembeddable, Square Sensors

Part Number	A	B	C	D	E	F
Ni75U-Q80	240.00	225.00	60.00	450.00	80.00	80.00

Dimensions are in mm.

We reserve the right to make technical alterations without prior notice.

## Rectangular Inductive Sensors

### Embeddable Mounting Characteristics - Rectangular Housings

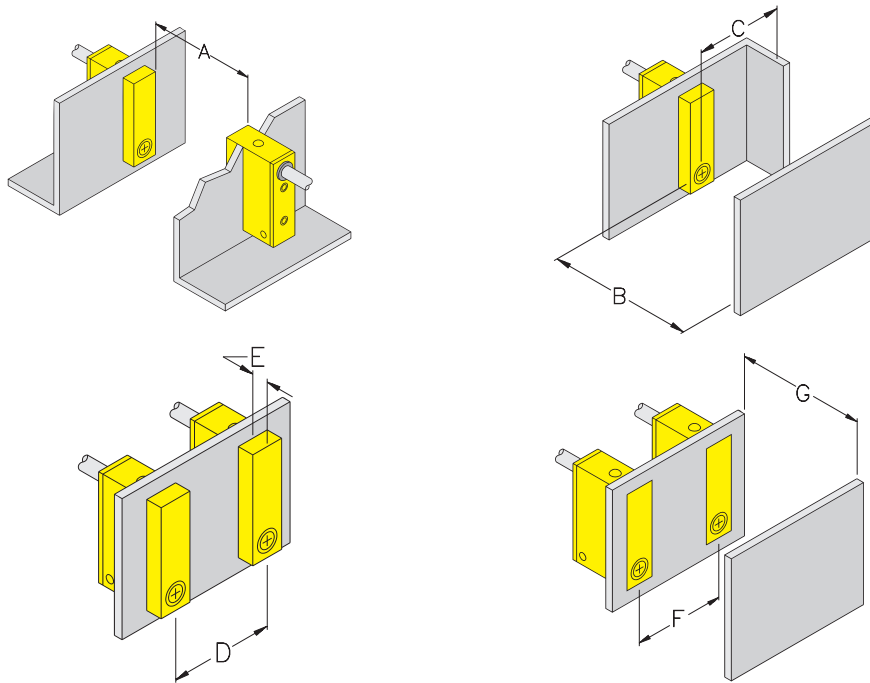

We reserve the right to make technical alterations without prior notice.

Rectangular Inductive Sensors

#### Flush Mountable

Housing Type	Sensor Type	Housing	A	C	F	G
Q6.5	Bi1	6.50	6.00	7.00	13.00	3.00
Q10S	Bi2	10.00	12.00	10.00	20.00	6.00
Q12	Bi2	12.00	12.00	12.00	24.00	6.00

Dimensions are in mm.

#### Non-Flush Mountable

Housing Type	Sensor Type	Housing	A	B	C	D	E
Q6.5	Ni2	6.50	12.00	6.00	10.00	20.00	4.00
Q9.5	Ni2	9.50	12.00	6.00	14.00	19.00	4.00
Q12	Ni4	12.00	24.00	12.00	18.00	24.00	8.00
Q25	Ni10	25.00	60.00	30.00	38.00	75.00	20.00
Q30	Ni15	30.00	90.00	45.00	45.00	90.00	30.00

Dimensions are in mm.



# Rectangular Inductive Sensors

## Embeddable Mounting Characteristics

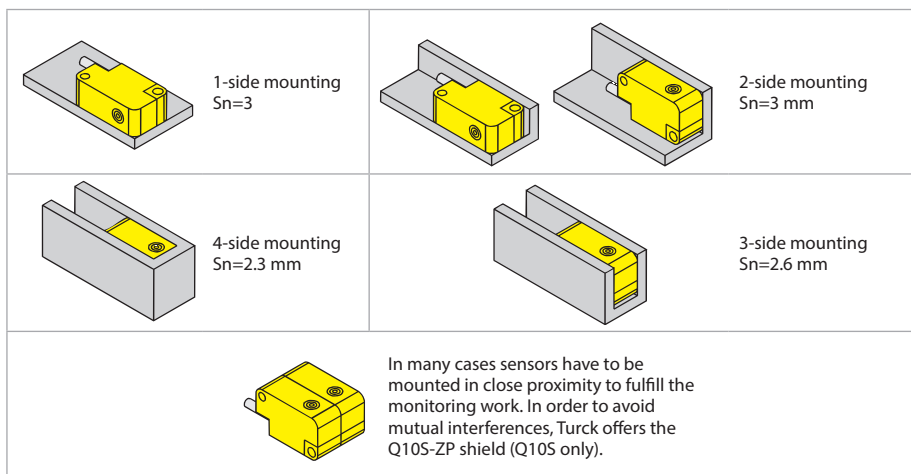
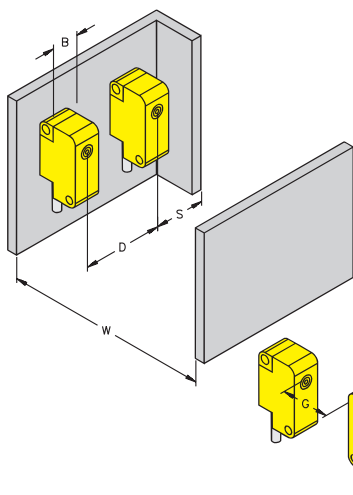

## Nonembeddable, Square Sensors

Part Number	D	W	S	G	B Width of Active Face
Ni5U-Q10S	31.00	15.00	15.30	30.00	10.20

Dimensions are in mm.

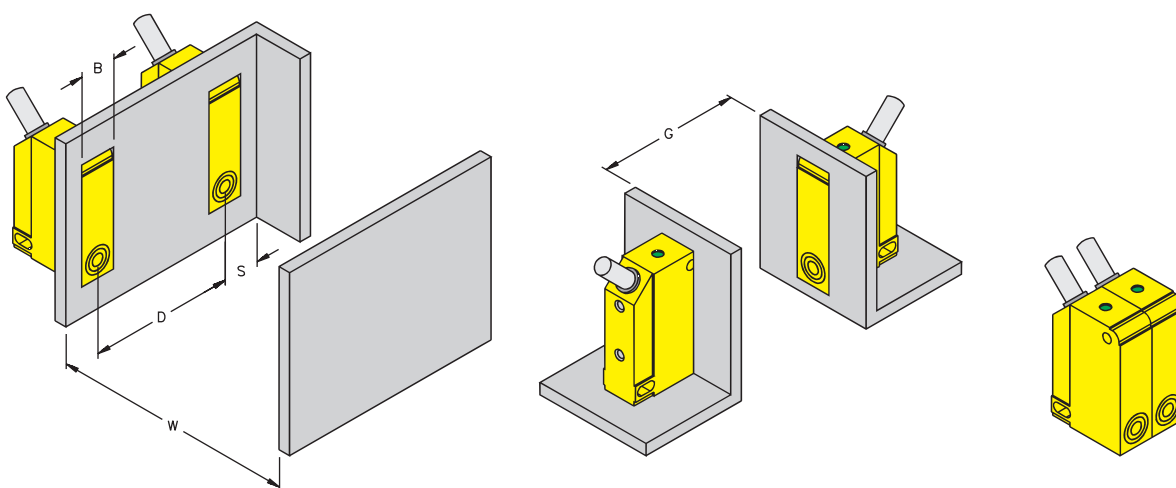

## Embeddable, Square Sensors

Part Number	D	W	S	G	B Width of Active Face
Bi5U-Q12	48.00	25.00	12.00	50.00	12.00

Dimensions are in mm.

We reserve the right to make technical alterations without prior notice.

Notes

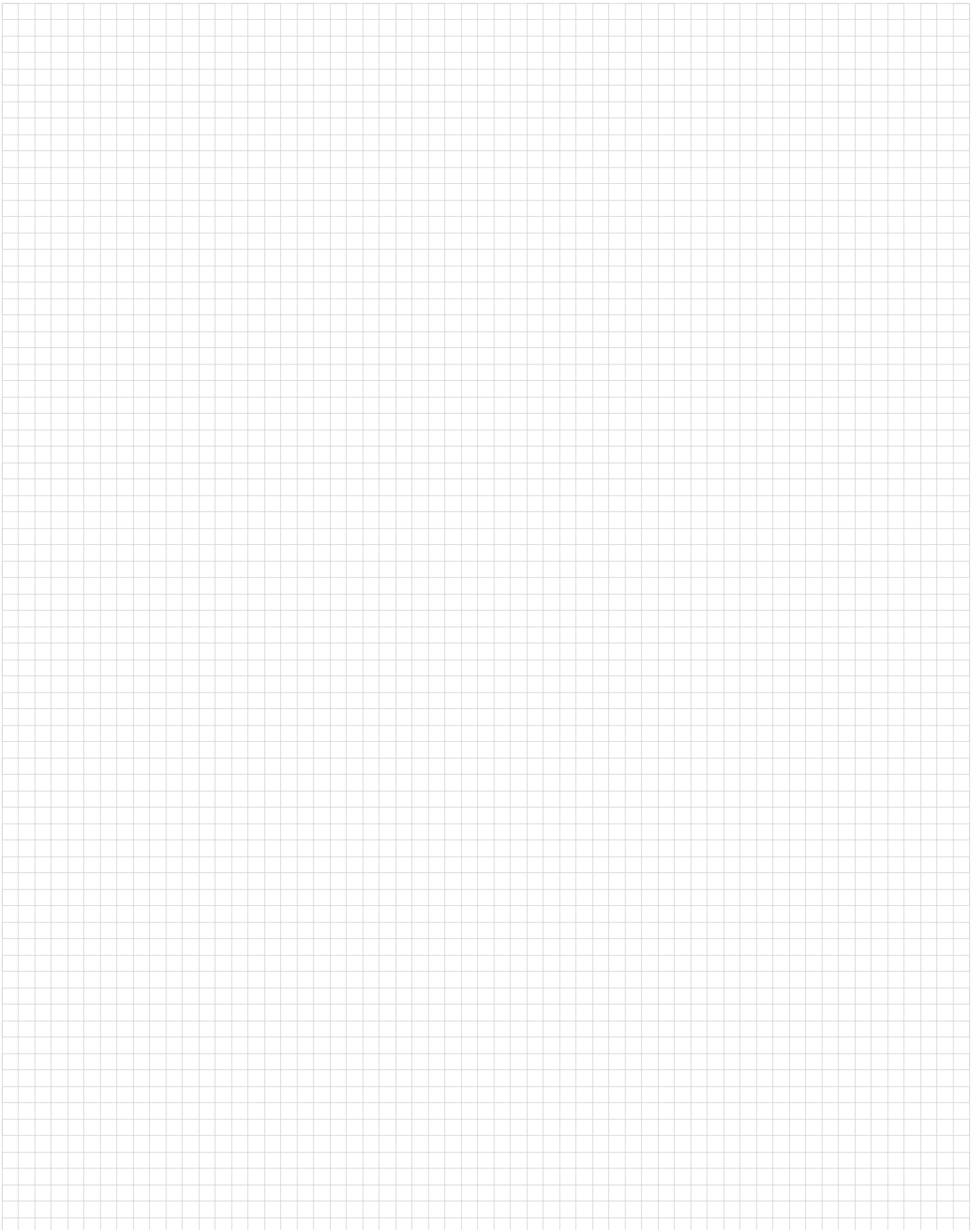

# Rectangular Inductive Sensors | Q4.7, Q5.5, & Q06

## Top Sensing Subminiature Qpak Housing

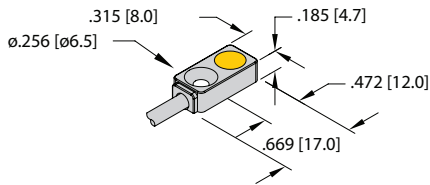
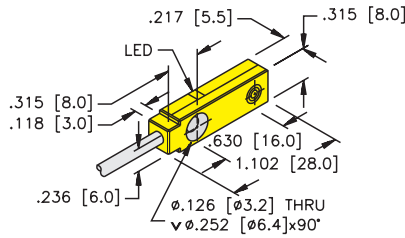
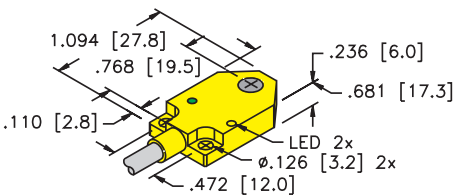
Housing Style	Dimension Drawings
	<p><b>A</b></p>  <p>4.7 mm - Embeddable, Potted-In Cable</p>
<p><b>B</b></p>  <p>5.5 mm - Embeddable/Nonembeddable, Potted-In Cable</p>	<p><b>C</b></p>  <p>6.0 mm - Embeddable, Potted-In Cable</p>

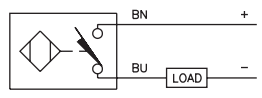
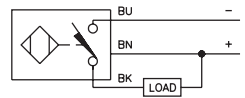
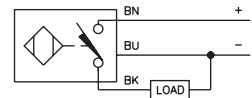
Wiring Diagrams/Mating Cordsets		
<p><b>1</b></p> 	<p><b>2</b></p> 	<p><b>3</b></p> 

A2 2-wire DC - (AD, RD, AG)	
<p>Ripple: <math>\leq 10\%</math>                      Differential Travel (Hysteresis): 3-15% (5% typical)                      Voltage Drop Across Conducting Sensor: Non-polarized (AD) <math>&lt; 5.0\text{ V}</math>                      Polarized (AG) <math>\leq 4.2\text{ V}</math>                      Trigger Current for Short Circuit Protection: <math>\geq 120\text{ mA}</math>                      Minimum Load Current: <math>\geq 3.0\text{ mA}</math></p>	<p>Off-State (Leakage) Current: <math>\leq 0.8\text{ mA}</math>                      Power-On Effect: Per IEC 947-5-2                      Transient Protection: Per EN 60947-5-2                      Shock: 30 g, 11 ms                      Vibration: 55 Hz, 1 mm Amplitude in all 3 Planes                      Repeatability: <math>\leq 2\%</math> of Rated Operating Distance</p>
A4 3 and 4-wire DC - (AN, RN, AP, RP, VN, VP)	
<p>Ripple: <math>\leq 10\%</math>                      Differential Travel (Hysteresis): 3-15% (5% typical)                      Voltage Drop Across Conducting Sensor: <math>\leq 1.8\text{ V}</math>                      Trigger Current for Short Circuit Protection: <math>\geq 220\text{ mA}</math> on 200 mA Load Current  <math>\geq 170\text{ mA}</math> on 150 mA Load Current  <math>\geq 120\text{ mA}</math> on 100 mA Load Current                      Off-State (Leakage) Current: <math>\leq 0.1\text{ mA}</math>                      No-Load Current: <math>\leq 15\text{ mA}</math> (Ferrite, Uprox, Rectangular)  <math>\leq 20\text{ mA}</math> (Uprox+, Uprox 3)                      Time Delay Before Availability: <math>\leq 8\text{ ms}</math></p>	<p>Power-On Effect: Per IEC 947-5-2                      Reverse Polarity Protection: Incorporated                      Wire-Break Protection: Incorporated                      Transient Protection: Per EN 60947-5-2                      Temperature Drift: <math>\leq \pm 10\%</math>                      Shock: 30 g, 11 ms                      Vibration: 55 Hz, 1 mm Amplitude in all 3 Planes                      Repeatability: <math>\leq 2\%</math> of Rated Operating Distance</p>

We reserve the right to make technical alterations without prior notice.

# Rectangular Inductive Sensors | Q4.7, Q5.5, & Q06

## Top Sensing Subminiature Qpak Housing

Part Number/ ID Number	Features	Embeddable	Sensing Range (mm)	Output	Voltage	Switching Freq. (Hz)	Operating Current (mA)	Operating Temp. (°C)	Protection	Housing	Front Cap/Face	Power LED	Output LED	Cable Length/Jacket	Dimension Drawings	Wiring Diagrams	Spec List
Bi2-Q4.7-AN6X 1614001		•	2	3-wire DC NPN	10-30 VDC	1000	≤100	0 to +85	IP67	Zinc	PA	N/A	YE	2M/TPU	A	2	A4
Bi2-Q4.7-AP6X 1614000		•	2	3-wire DC NPN	10-30 VDC	1000	≤100	0 to +85	IP67	Zinc	PA	N/A	YE	2M/TPU	A	3	A4
Bi2-Q5.5-AG6X 1613108		•	2	2-wire DC	10-30 VDC	1000	≤50	-25 to +70	IP67	PP	PP	N/A	YE	2M/TPU	B	1	A2
Bi2-Q5.5-AN6X 1613100		•	2	3-wire DC NPN	10-30 VDC	2000	≤150	-25 to +85	IP67	PP	PP	N/A	YE	2M/TPU	B	2	A4
Bi2-Q5.5-AN6X/S34 1613101	WFI	•	2	3-wire DC NPN	10-30 VDC	2000	≤150	-25 to +70	IP67	PP	PP	N/A	YE	2M/TPU	B	2	A4
Ni3.5-Q5.5-AN6X 4613610			3.5	3-wire DC NPN	10-30 VDC	2000	≤150	-25 to +70	IP67	PP	PP	N/A	YE	2M/TPU	B	2	A4
Bi2-Q5.5-AP6X 1613000		•	2	3-wire DC PNP	10-30 VDC	2000	≤150	-25 to +85	IP67	PP	PP	N/A	YE	2M/TPU	B	3	A4
Bi2-Q5.5-AP6X/S34 1613001	WFI	•	2	3-wire DC PNP	10-30 VDC	2000	≤150	-25 to +70	IP67	PP	PP	N/A	YE	2M/TPU	B	3	A4
Ni3.5-Q5.5-AP6X 4613601			3.5	3-wire DC PNP	10-30 VDC	2000	≤150	-25 to +70	IP67	PP	PP	N/A	YE	2M/TPU	B	3	A4
Bi3-Q06-AN6X2 1620150		•	3	3-wire DC NPN	10-30 VDC	1000	≤200	-25 to +70	IP67	PBT	PA	GN	YE	2M/TPU	C	2	A4
Bi3-Q06-AP6X2 1620100		•	3	3-wire DC PNP	10-30 VDC	1000	≤200	-25 to +70	IP67	PBT	PA	GN	YE	2M/TPU	C	3	A4

We reserve the right to make technical alterations without prior notice.

Rectangular Inductive Sensors

# Rectangular Inductive Sensors | Q08

## Top Sensing Qpak Housing with Potted-in Cable

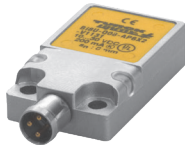
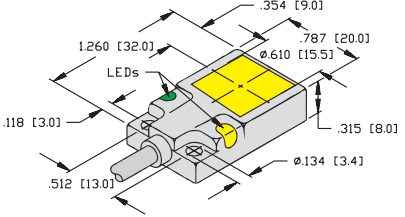
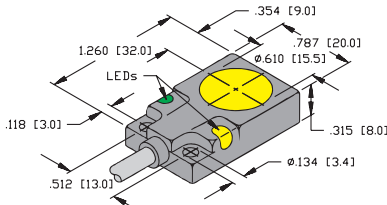
Housing Style	Dimension Drawings
	<p><b>A</b></p>  <p>8.0 mm - Embeddable, Potted-In Cable</p>
<p><b>B</b></p>  <p>8.0 mm - Embeddable, Potted-In Cable</p>	

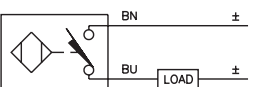
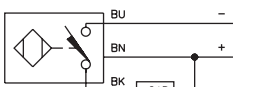
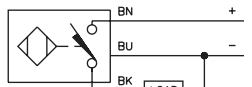
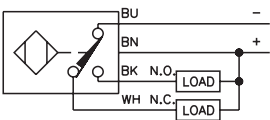
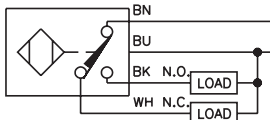
Wiring Diagrams/Mating Cordsets		
<p><b>1</b></p> 	<p><b>2</b></p> 	<p><b>3</b></p> 
<p><b>4</b></p> 	<p><b>5</b></p> 	

A2 2-wire DC - (AD, RD, AG)	
<p>Ripple: <math>\leq 10\%</math>                      Differential Travel (Hysteresis): 3-15% (5% typical)                      Voltage Drop Across Conducting Sensor: Non-polarized (AD) <math>&lt; 5.0\text{ V}</math>                      Polarized (AG) <math>\leq 4.2\text{ V}</math>                      Trigger Current for Short Circuit Protection: <math>\geq 120\text{ mA}</math>                      Minimum Load Current: <math>\geq 3.0\text{ mA}</math></p>	<p>Off-State (Leakage) Current: <math>\leq 0.8\text{ mA}</math>                      Power-On Effect: Per IEC 947-5-2                      Transient Protection: Per EN 60947-5-2                      Shock: 30 g, 11 ms                      Vibration: 55 Hz, 1 mm Amplitude in all 3 Planes                      Repeatability: <math>\leq 2\%</math> of Rated Operating Distance</p>
A4 3 and 4-wire DC - (AN, RN, AP, RP, VN, VP)	
<p>Ripple: <math>\leq 10\%</math>                      Differential Travel (Hysteresis): 3-15% (5% typical)                      Voltage Drop Across Conducting Sensor: <math>\leq 1.8\text{ V}</math>                      Trigger Current for Short Circuit Protection: <math>\geq 220\text{ mA}</math> on 200 mA Load Current  <math>\geq 170\text{ mA}</math> on 150 mA Load Current  <math>\geq 120\text{ mA}</math> on 100 mA Load Current                      Off-State (Leakage) Current: <math>\leq 0.1\text{ mA}</math>                      No-Load Current: <math>\leq 15\text{ mA}</math> (Ferrite, Uprox, Rectangular)  <math>\leq 20\text{ mA}</math> (Uprox+, Uprox 3)                      Time Delay Before Availability: <math>\leq 8\text{ ms}</math></p>	<p>Power-On Effect: Per IEC 947-5-2                      Reverse Polarity Protection: Incorporated                      Wire-Break Protection: Incorporated                      Transient Protection: Per EN 60947-5-2                      Temperature Drift: <math>\leq \pm 10\%</math>                      Shock: 30 g, 11 ms                      Vibration: 55 Hz, 1 mm Amplitude in all 3 Planes                      Repeatability: <math>\leq 2\%</math> of Rated Operating Distance</p>

We reserve the right to make technical alterations without prior notice.

# Rectangular Inductive Sensors | Q08

## Top Sensing Qpak Housing with Potted-in Cable

Part Number/ ID Number	Features	Embeddable	Sensing Range (mm)	Output	Voltage	Switching Freq. (Hz)	Operating Current (mA)	Operating Temp. (°C)	Protection	Housing	Front Cap/Face	Power LED	Output LED	Cable Length/Jacket	Dimension Drawings	Wiring Diagrams	Spec List
Bi5U-Q08-AN6X2 1608911	Uprox	•	5	3-wire DC NPN	10-30 VDC	250	≤200	-30 to +85	IP67	Zinc	PA 12	GN	YE	2M/TPU	B	2	A4
Bi5U-Q08-AP6X2 1608901	Uprox	•	5	3-wire DC PNP	10-30 VDC	250	≤200	-30 to +85	IP67	Zinc	PA 12	GN	YE	2M/TPU	B	3	A4
Bi5-Q08-AD4X/S34 4414550	WFI	•	5	2-wire DC	10-65 VDC	50	≤100	-25 to +70	IP67	Zinc	PA 12	N/A	YE	2M/TPU	B	1	A2
Bi5-Q08-VN6X2 1600200	Comp. Outputs	•	5	4-wire DC NPN	10-30 VDC	1000	≤200	-25 to +70	IP67	Zinc	PA 12	GN	YE	2M/TPU	B	4	A4
Bi5-Q08-VP6X2 1600100	Comp. Outputs	•	5	4-wire DC PNP	10-30 VDC	1000	≤200	-25 to +70	IP67	Zinc	PA 12	GN	YE	2M/TPU	B	5	A4
Bi7-Q08-AN6X2 1601620	Ext. Range	•	7	3-wire DC NPN	10-30 VDC	500	≤200	-25 to +70	IP67	Zinc	PA 12	GN	YE	2M/TPU	B	2	A4
Bi7-Q08-AP6X2 1601600	Ext. Range	•	7	3-wire DC PNP	10-30 VDC	500	≤200	-25 to +70	IP67	Zinc	PA 12	GN	YE	2M/TPU	B	3	A4
Bi7-Q08-VN6X2 1600920	Ext. Range	•	7	4-wire DC NPN	10-30 VDC	500	≤200	-25 to +70	IP67	Zinc	PA 12	GN	YE	2M/TPU	B	4	A4
Bi7-Q08-VP6X2 1600900	Ext. Range	•	7	4-wire DC PNP	10-30 VDC	500	≤200	-25 to +70	IP67	Zinc	PA 12	GN	YE	2M/TPU	B	5	A4
Bi8U-Q08-AN6X2 1662007	Uprox+	•	8	3-wire DC NPN	10-30 VDC	1000	≤200	-30 to +85	IP68	Zinc	PA12	GN	YE	2M/TPU	A	2	A4
Bi8U-Q08-AP6X2 1662006	Uprox+	•	8	3-wire DC PNP	10-30 VDC	1000	≤200	-30 to +85	IP68	Zinc	PA12	GN	YE	2M/TPU	A	3	A4

We reserve the right to make technical alterations without prior notice.

Rectangular Inductive Sensors

# Rectangular Inductive Sensors | Q08

## Top Sensing Qpak Housing with Integral Connector

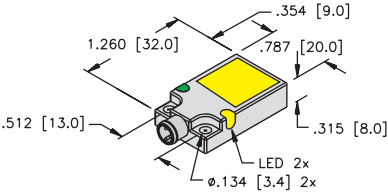
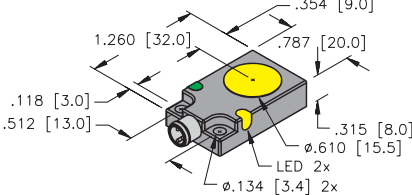
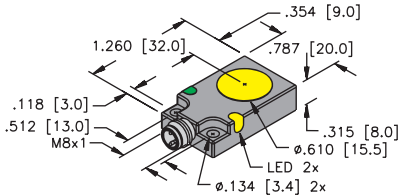
Housing Style	Dimension Drawings
	<p><b>A</b></p>  <p>8.0 mm - Embeddable, Picofast Connector</p>
<p><b>B</b></p>  <p>8.0 mm - Embeddable, M8 snap-on Picofast Connector</p>	<p><b>C</b></p>  <p>8.0 mm - Embeddable, M8 thread-on Picofast Connector</p>

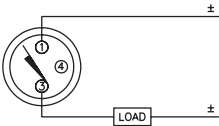
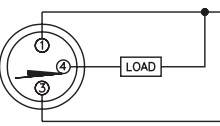
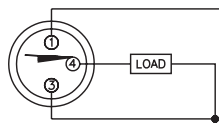
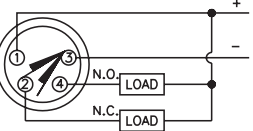
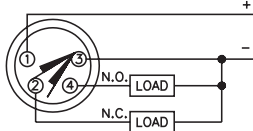
Wiring Diagrams/Mating Cordsets		
<p><b>1</b></p>  <p>Mating Cordset: PKG 3Z-*; PKG 3M-*</p>	<p><b>2</b></p>  <p>Mating Cordset: PKG 3Z-*; PKG 3M-*</p>	<p><b>3</b></p>  <p>Mating Cordset: PKG 3Z-*; PKG 3M-*</p>
<p><b>4</b></p>  <p>Mating Cordset: PKG 4Z-*</p>	<p><b>5</b></p>  <p>Mating Cordset: PKG 4Z-*</p>	

A2	2-wire DC - (AD, RD, AG)	
<p>Ripple: ≤10%</p> <p>Differential Travel (Hysteresis): 3-15% (5% typical)</p> <p>Voltage Drop Across Conducting Sensor: Non-polarized (AD) &lt;5.0 V Polarized (AG) ≤4.2 V</p> <p>Trigger Current for Short Circuit Protection: ≥120 mA</p> <p>Minimum Load Current: ≥3.0 mA</p>		<p>Off-State (Leakage) Current: ≤0.8 mA</p> <p>Power-On Effect: Per IEC 947-5-2</p> <p>Transient Protection: Per EN 60947-5-2</p> <p>Shock: 30 g, 11 ms</p> <p>Vibration: 55 Hz, 1 mm Amplitude in all 3 Planes</p> <p>Repeatability: ≤2% of Rated Operating Distance</p>

A4	3 and 4-wire DC - (AN, RN, AP, RP, VN, VP)	
<p>Ripple: ≤10%</p> <p>Differential Travel (Hysteresis): 3-15% (5% typical)</p> <p>Voltage Drop Across Conducting Sensor: ≤1.8 V</p> <p>Trigger Current for Short Circuit Protection: ≥220 mA on 200 mA Load Current ≥170 mA on 150 mA Load Current ≥120 mA on 100 mA Load Current</p> <p>Off-State (Leakage) Current: ≤0.1 mA</p> <p>No-Load Current: ≤15 mA (Ferrite, Uprox, Rectangular) ≤20 mA (Uprox+, Uprox 3)</p> <p>Time Delay Before Availability: ≤8 ms</p>		<p>Power-On Effect: Per IEC 947-5-2</p> <p>Reverse Polarity Protection: Incorporated</p> <p>Wire-Break Protection: Incorporated</p> <p>Transient Protection: Per EN 60947-5-2</p> <p>Temperature Drift: ±10%</p> <p>Shock: 30 g, 11 ms</p> <p>Vibration: 55 Hz, 1 mm Amplitude in all 3 Planes</p> <p>Repeatability: ≤2% of Rated Operating Distance</p>

We reserve the right to make technical alterations without prior notice.

# Rectangular Inductive Sensors | Q08

## Top Sensing Qpak Housing with Integral Connector

Part Number/ ID Number	Features	Embeddable	Sensing Range (mm)	Output	Voltage	Switching Freq. (Hz)	Operating Current (mA)	Operating Temp. (°C)	Protection	Housing	Front Cap/Face	Power LED	Output LED	Mating Cord	Dimension Drawings	Wiring Diagrams	Spec List
Bi5U-Q08-AN6X2-V1131 1608910	Uprox	•	5	3-wire DC NPN	10-30 VDC	250	≤200	-30 to +85	IP67	Zinc	PA 12	GN	YE	PKG 3Z-*	B	2	A4
Bi5U-Q08-AP6X2-V1131 1608900	Uprox	•	5	3-wire DC PNP	10-30 VDC	250	≤200	-30 to +85	IP67	Zinc	PA 12	GN	YE	PKG 3Z-*	B	3	A4
Bi5U-Q08-AN6X2-V2131 1608904	Uprox	•	5	3-wire DC NPN	10-30 VDC	250	≤200	-30 to +85	IP67	Zinc	PA 12	GN	YE	PKG 3M-*	C	2	A4
Bi5U-Q08-AP6X2-V2131 1608905	Uprox	•	5	3-wire DC PNP	10-30 VDC	250	≤200	-30 to +85	IP67	Zinc	PA 12	GN	YE	PKG 3M-*	C	3	A4
Bi5-Q08-AD4X-V1130 4414551		•	5	2-wire DC	10-65 VDC	1000	≤100	-25 to +70	IP67	Zinc	PA 12	N/A	YE	PKG 3Z-*	B	1	A2
Bi5-Q08-AN6X2-V1131 1600600		•	5	3-wire DC NPN	10-30 VDC	1000	≤200	-25 to +70	IP67	Zinc	PA 12	GN	YE	PKG 3Z-*	B	2	A4
Bi5-Q08-AP6X2-V1131 1600500		•	5	3-wire DC PNP	10-30 VDC	1000	≤200	-25 to +70	IP67	Zinc	PA 12	GN	YE	PKG 3Z-*	B	3	A4
Bi5-Q08-VN6X2-V1141 1600400	Comp. Outputs	•	5	4-wire DC NPN	10-30 VDC	1000	≤200	-25 to +70	IP67	Zinc	PA 12	GN	YE	PKG 4Z-*	B	4	A4
Bi5-Q08-VP6X2-V1141 1600300	Comp. Outputs	•	5	4-wire DC PNP	10-30 VDC	1000	≤200	-25 to +70	IP67	Zinc	PA 12	GN	YE	PKG 4Z-*	B	5	A4
Bi5-Q08-AD4X-V2130 4414553		•	5	2-wire DC	10-65 VDC	1000	≤100	-25 to +70	IP67	Zinc	PA 12	N/A	YE	PKG 3M-*	C	1	A2
Bi5-Q08-AN6X2-V2131 1600602		•	5	3-wire DC NPN	10-30 VDC	1000	≤200	-25 to +70	IP67	Zinc	PA 12	GN	YE	PKG 3M-*	C	2	A4
Bi5-Q08-AP6X2-V2131 1600502		•	5	3-wire DC PNP	10-30 VDC	1000	≤200	-25 to +70	IP67	Zinc	PA 12	GN	YE	PKG 3M-*	C	3	A4
Bi7-Q08-AN6X2-V1131 1601622	Ext. Range	•	7	3-wire DC NPN	10-30 VDC	500	≤200	-25 to +70	IP67	Zinc	PA 12	GN	YE	PKG 3Z-*	B	2	A4
Bi7-Q08-AP6X2-V1131 1601602	Ext. Range	•	7	3-wire DC PNP	10-30 VDC	500	≤200	-25 to +70	IP67	Zinc	PA 12	GN	YE	PKG 3Z-*	B	3	A4
Bi7-Q08-AN6X2-V2131 1601623	Ext. Range	•	7	3-wire DC NPN	10-30 VDC	500	≤200	-25 to +70	IP67	Zinc	PA 12	GN	YE	PKG 3M-*	C	2	A4
Bi7-Q08-AP6X2-V2131 1601603	Ext. Range	•	7	3-wire DC PNP	10-30 VDC	500	≤200	-25 to +70	IP67	Zinc	PA 12	GN	YE	PKG 3M-*	C	3	A4
Bi7-Q08-VN6X2-V1141 1600922	Ext. Range	•	7	4-wire DC NPN	10-30 VDC	500	≤200	-25 to +70	IP67	Zinc	PA 12	GN	YE	PKG 4Z-*	B	4	A4
Bi7-Q08-VP6X2-V1141 1600902	Ext. Range	•	7	4-wire DC PNP	10-30 VDC	1000	≤200	-25 to +70	IP67	Zinc	PA 12	GN	YE	PKG 4Z-*	B	5	A4
Bi8U-Q08-AN6X2-V1131 1662008	Uprox+	•	8	3-wire DC NPN	10-30 VDC	1000	≤200	-30 to +85	IP68	Zinc	PA 12	GN	YE	PKG 3Z-*	A	2	A4
Bi8U-Q08-AP6X2-V1131 1662005	Uprox+	•	8	3-wire DC PNP	10-30 VDC	1000	≤200	-30 to +85	IP68	Zinc	PA 12	GN	YE	PKG 3Z-*	A	3	A4

We reserve the right to make technical alterations without prior notice.

Rectangular Inductive Sensors



# Rectangular Inductive Sensors | Q8SE & Q10S

## Side Sensing Qpak Housing

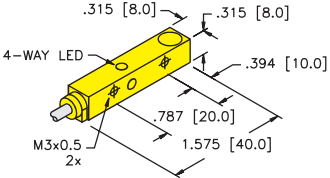
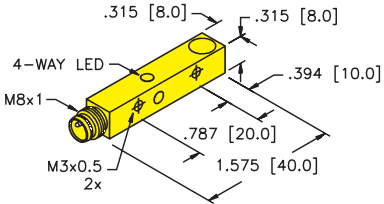
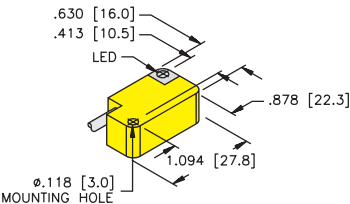
Housing Style	Dimension Drawings
	<p><b>A</b></p>  <p>8.0 mm - Nonembeddable, Potted-In Cable</p>
<p><b>B</b></p>  <p>8.0 mm - Nonembeddable, M8 Picofast Connector</p>	<p><b>C</b></p>  <p>10 mm - Embeddable/Nonembeddable, Potted-In Cable</p>

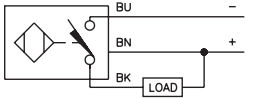
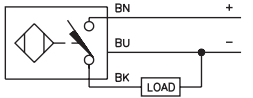
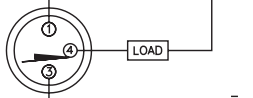
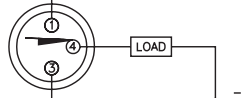
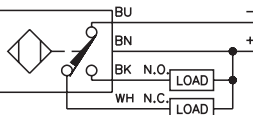
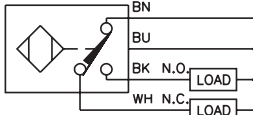
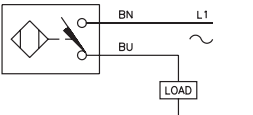
Wiring Diagrams/Mating Cordsets			
<p>1</p> 	<p>2</p> 	<p>3</p>  <p>Mating Cordset: PKG 3Z-*</p>	<p>4</p>  <p>Mating Cordset: PKG 3Z-*</p>
<p>5</p> 	<p>6</p> 	<p>7</p> 	

A4 3 and 4-wire DC - (AN, RN, AP, RP, VN, VP)	
<p>Ripple: ≤10%</p> <p>Differential Travel (Hysteresis): 3-15% (5% typical)</p> <p>Voltage Drop Across Conducting Sensor: ≤1.8 V</p> <p>Trigger Current for Short Circuit Protection: ≥220 mA on 200 mA Load Current ≥170 mA on 150 mA Load Current ≥120 mA on 100 mA Load Current</p> <p>Off-State (Leakage) Current: ≤0.1 mA</p> <p>No-Load Current: ≤15 mA (Ferrite, Uprox, Rectangular) ≤20 mA (Uprox+, Uprox 3)</p> <p>Time Delay Before Availability: ≤8 ms</p>	<p>Power-On Effect: Per IEC 947-5-2</p> <p>Reverse Polarity Protection: Incorporated</p> <p>Wire-Break Protection: Incorporated</p> <p>Transient Protection: Per EN 60947-5-2</p> <p>Temperature Drift: ≤±10%</p> <p>Shock: 30 g, 11 ms</p> <p>Vibration: 55 Hz, 1 mm Amplitude in all 3 Planes</p> <p>Repeatability: ≤2% of Rated Operating Distance</p>

A6 2-wire AC/DC w/o Short-Circuit Protection - (AZ, RZ, FZ)	
<p>Line Frequency: ≥50... ≤60 Hz</p> <p>Differential Travel (Hysteresis): 3-15% (5% typical)</p> <p>Voltage Drop Across Conducting Sensor: ≤6.0 V</p> <p>Continuous Load Current: AC: ≤400 mA; DC: ≤300 mA AC: ≤100 mA; DC: ≤100 mA</p> <p>Off-State (Leakage) Current: ≤1.7 mA</p> <p>Minimum Load Current: ≥3.0 mA</p>	<p>Inrush Current: ≤8 A (≤10ms max. 5 Hz) ≤1 A (≤10 ms max. 5 Hz) 12 mm ≤0.2 A (≤10 ms max. 0.2 Hz) 8 mm</p> <p>Power-On Effect: Per IEC 947-5-2</p> <p>Transient Protection: Per EN 60947-5-2</p> <p>Shock: 30 g, 11 ms</p> <p>Vibration: 55 Hz, 1 mm Amplitude, in all 3 Planes</p> <p>Repeatability: ≤2% of Rated Operating Distance</p>

We reserve the right to make technical alterations without prior notice.

# Rectangular Inductive Sensors | Q8SE & Q10S

## Side Sensing Qpak Housing

Part Number/ ID Number	Features	Embeddable	Sensing Range (mm)	Output	Voltage	Switching Freq. (Hz)	Operating Current (mA)	Operating Temp. (°C)	Protection	Housing	Front Cap/Face	Power LED	Output LED	Cable Length/Jacket	Dimension Drawings	Wiring Diagrams	Spec List
Ni4U-Q8SE-AN6X 4635809	Uprox+		4	3-wire DC NPN	10-30 VDC	1000	≤150	-30 to +85	IP68	PP	PP	N/A	YE	2M/TPU	A	1	A4
Ni4U-Q8SE-AP6X 4635807	Uprox+		4	3-wire DC PNP	10-30 VDC	1000	≤150	-30 to +85	IP68	PP	PP	N/A	YE	2M/TPU	A	2	A4
Ni4U-Q8SE-AN6X-V1131 4635810	Uprox+		4	3-wire DC NPN	10-30 VDC	1000	≤150	-30 to +85	IP68	PP	PP	N/A	YE	--	B	3	A4
Ni4U-Q8SE-AP6X-V1131 4635808	Uprox+		4	3-wire DC PNP	10-30 VDC	1000	≤150	-30 to +85	IP68	PP	PP	N/A	YE	--	B	4	A4
Bi2-Q10S-AN6X 1619310		•	2	3-wire DC NPN	10-30 VDC	2000	≤150	-25 to +70	IP67	PP-GF20	PP	N/A	YE	2M/TPU	C	1	A4
Bi2-Q10S-AP6X 1609360		•	2	3-wire DC PNP	10-30 VDC	2000	≤150	-25 to +70	IP67	PP-GF20	PP	N/A	YE	2M/TPU	C	2	A4
Bi2-Q10S-VN6X 1609341	Comp. Outputs	•	2	4-wire DC NPN	10-30 VDC	2000	≤150	-25 to +70	IP67	PP-GF20	PP	N/A	YE	2M/TPU	C	5	A4
Bi2-Q10S-VP6X 1609340	Comp. Outputs	•	2	4-wire DC PNP	10-30 VDC	2000	≤150	-25 to +70	IP67	PP-GF20	PP- GF20	N/A	YE	2M/TPU	C	6	A4
Bi2-Q10S-AZ31X 1309100		•	2	2-wire AC	20-250 VAC/10-300 VDC	60	≤100	-25 to +70	IP67	PP-GF20	PP- GF20	N/A	RD	2M/TPU	C	7	A6
Ni5U-Q10S-AN6X 1609365	Uprox+		5	3-wire DC NPN	10-30 VDC	1000	≤150	-30 to +85	IP68	PP-GF20	PP- GF20	N/A	YE	2M/TPU	C	1	A4
Ni5U-Q10S-AP6X 1609364	Uprox+		5	3-wire DC PNP	10-30 VDC	1000	≤150	-30 to +85	IP68	PP-GF20	PP- GF20	N/A	YE	2M/TPU	C	2	A4

We reserve the right to make technical alterations without prior notice.

Rectangular Inductive Sensors

# Rectangular Inductive Sensors | Small Rectangular

## Sensor with Molded Connector

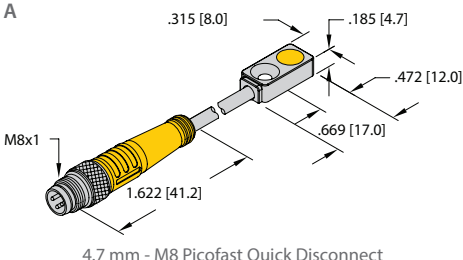
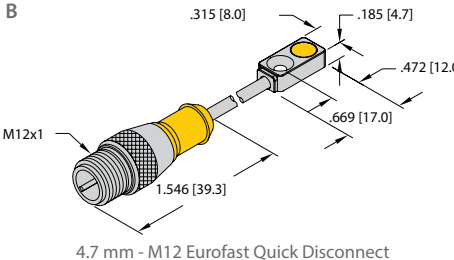
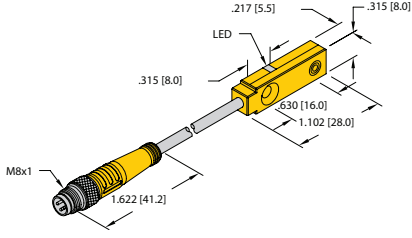
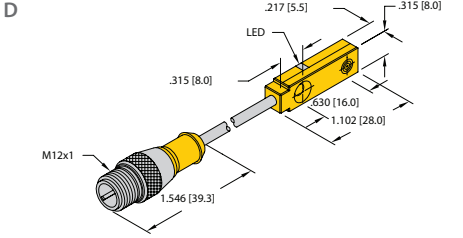
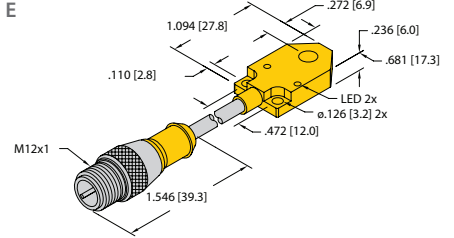
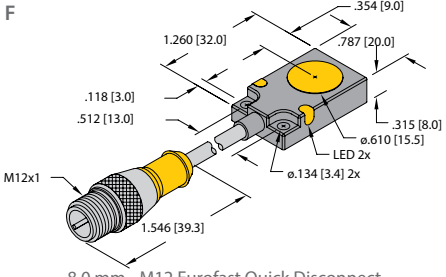
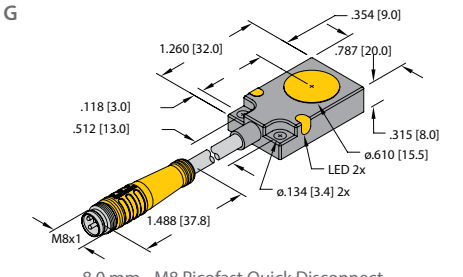
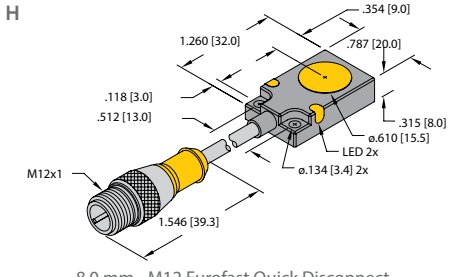
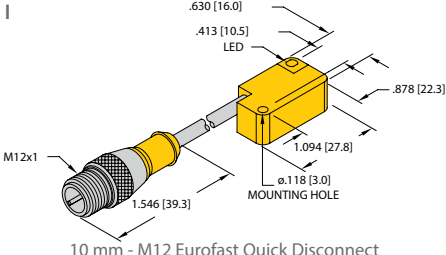
Housing Style	Dimension Drawings	
	<p><b>A</b></p>  <p>4.7 mm - M8 Picofast Quick Disconnect</p>	<p><b>B</b></p>  <p>4.7 mm - M12 Eurofast Quick Disconnect</p>
<p><b>C</b></p>  <p>5.5 mm - M8 Picofast Quick Disconnect</p>	<p><b>D</b></p>  <p>5.5 mm - M12 Eurofast Quick Disconnect</p>	<p><b>E</b></p>  <p>6.0 mm - M12 Eurofast Quick Disconnect</p>
<p><b>F</b></p>  <p>8.0 mm - M12 Eurofast Quick Disconnect</p>	<p><b>G</b></p>  <p>8.0 mm - M8 Picofast Quick Disconnect</p>	<p><b>H</b></p>  <p>8.0 mm - M12 Eurofast Quick Disconnect</p>
<p><b>I</b></p>  <p>10 mm - M12 Eurofast Quick Disconnect</p>		

We reserve the right to make technical alterations without prior notice.

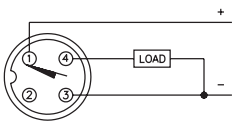
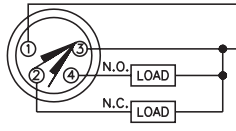
Wiring Diagrams/Mating Cordsets	
<p><b>1</b></p>  <p>Mating Cordset: RK 4T-*</p>	<p><b>2</b></p>  <p>Mating Cordset: PKG 3M-*</p>

A4 3 and 4-wire DC - (AN, RN, AP, RP, VN, VP)	
<p><b>Ripple:</b> ≤10%</p> <p><b>Differential Travel (Hysteresis):</b> 3-15% (5% typical)</p> <p><b>Voltage Drop Across Conducting Sensor:</b> ≤1.8 V</p> <p><b>Trigger Current for Short Circuit Protection:</b> ≥220 mA on 200 mA Load Current                      ≥170 mA on 150 mA Load Current                      ≥120 mA on 100 mA Load Current</p> <p><b>Off-State (Leakage) Current:</b> ≤0.1 mA</p> <p><b>No-Load Current:</b> ≤15 mA (Ferrite, Uprox, Rectangular)                      ≤20 mA (Uprox+, Uprox 3)</p> <p><b>Time Delay Before Availability:</b> ≤8 ms</p>	<p><b>Power-On Effect:</b> Per IEC 947-5-2</p> <p><b>Reverse Polarity Protection:</b> Incorporated</p> <p><b>Wire-Break Protection:</b> Incorporated</p> <p><b>Transient Protection:</b> Per EN 60947-5-2</p> <p><b>Temperature Drift:</b> ≤±10%</p> <p><b>Shock:</b> 30 g, 11 ms</p> <p><b>Vibration:</b> 55 Hz, 1 mm Amplitude in all 3 Planes</p> <p><b>Repeatability:</b> ≤2% of Rated Operating Distance</p>

## Rectangular Inductive Sensors | Small Rectangular Sensor with Molded Connector

Part Number/ ID Number	Features	Embeddable	Sensing Range (mm)	Output	Voltage	Switching Freq. (Hz)	Operating Current (mA)	Operating Temp. (°C)	Protection	Housing	Front Cap/Face	Power LED	Output LED	Cable Length/Jacket	Dimension Drawings	Wiring Diagrams	Spec List
Bi2-Q4.7-AP6X-0.3-PSG3M 1614000		•	2	3-wire DC PNP	10-30 VDC	1000	≤100	0 to +85	IP67	Zinc	PA	N/A	YE	0.3M/TPU	A	2	A4
Bi2-Q4.7-AP6X-0.3-RS4T 16140024		•	2	3-wire DC PNP	10-30 VDC	1000	≤100	0 to +85	IP67	Zinc	PA	N/A	YE	0.3M/TPU	B	1	A4
Bi2-Q5.5-AP6X-0.2-PSG3M 1613099		•	2	3-wire DC PNP	10-30 VDC	2000	≤150	-25 to +85	IP67	PP	PP	N/A	YE	0.2M/TPU	C	2	A4
Bi2-Q5.5-AP6X-0.2-RS4T 1613094		•	2	3-wire DC PNP	10-30 VDC	2000	≤150	-25 to +85	IP67	PP	PP	N/A	YE	0.2M/TPU	D	1	A4
Bi3-Q06-AP6X2-0.2-RS4T 1620193		•	3	3-wire DC PNP	10-30 VDC	1000	≤200	-25 to +70	IP67	PBT	PA	GN	YE	0.2M/TPU	E	1	A4
Bi5U-Q08-AP6X2-0.2-RS4T 1608990	Uprox	•	5	3-wire DC PNP	10-30 VDC	250	≤200	-30 to +85	IP67	Zinc	PA 12	GN	YE	0.2M/TPU	F	1	A4
Bi5-Q08-AP6X2-0.2-PSG3F 1600592		•	5	3-wire DC PNP	10-30 VDC	250	≤200	-25 to +70	IP67	Zinc	PA 12	GN	YE	0.2M/TPU	G	2	A4
Bi7-Q08-AP6X2-0.2-RS4T 1601683		•	7	3-wire DC PNP	10-30 VDC	500	≤200	-25 to +70	IP67	Zinc	PA 12	GN	YE	0.2M/TPU	H	1	A4
Bi2-Q10S-AP6X-0.2-RS4T 1609390		•	2	3-wire DC PNP	10-30 VDC	2000	≤150	-25 to +70	IP67	PP-GF20	PP	N/A	YE	0.2M/TPU	I	1	A4

We reserve the right to make technical alterations without prior notice.

Rectangular Inductive Sensors

# Rectangular Inductive Sensors | Q10

## Top Sensing Qpak Housing

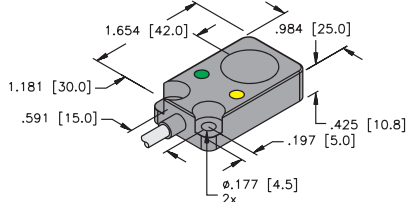
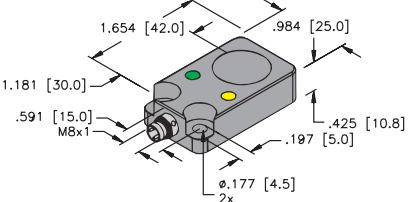
Housing Style	Dimension Drawings
	<p><b>A</b></p>  <p>10 mm - Embeddable, Potted-In Cable</p>
<p><b>B</b></p>  <p>10 mm - Embeddable, M8 Picofast Connector</p>	

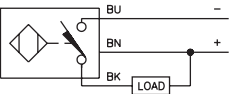
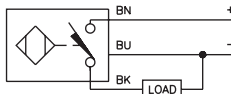
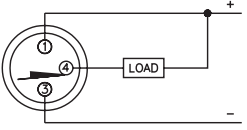
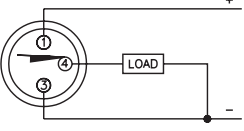
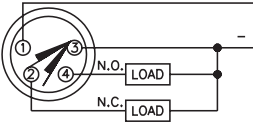
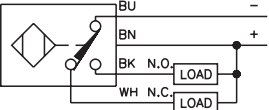
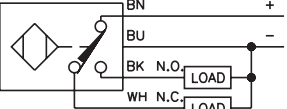
Wiring Diagrams/Mating Cordsets		
<p>1</p> 	<p>2</p> 	<p>3</p>  <p>Mating Cordset: PKG 3Z-*</p>
<p>4</p>  <p>Mating Cordset: PKG 3Z-*</p>	<p>5</p>  <p>Mating Cordset: PKG 4Z-*</p>	<p>6</p> 
<p>7</p> 		

A4 3 and 4-wire DC - (AN, RN, AP, RP, VN, VP)		
<p>Ripple: <math>\leq 10\%</math></p> <p>Differential Travel (Hysteresis): 3-15% (5% typical)</p> <p>Voltage Drop Across Conducting Sensor: <math>\leq 1.8\text{ V}</math></p> <p>Trigger Current for Short Circuit Protection:  <math>\geq 220\text{ mA}</math> on 200 mA Load Current  <math>\geq 170\text{ mA}</math> on 150 mA Load Current  <math>\geq 120\text{ mA}</math> on 100 mA Load Current</p> <p>Off-State (Leakage) Current: <math>\leq 0.1\text{ mA}</math></p> <p>No-Load Current: <math>\leq 15\text{ mA}</math> (Ferrite, Uprox, Rectangular)  <math>\leq 20\text{ mA}</math> (Uprox+, Uprox 3)</p> <p>Time Delay Before Availability: <math>\leq 8\text{ ms}</math></p>	<p>Power-On Effect: Per IEC 947-5-2</p> <p>Reverse Polarity Protection: Incorporated</p> <p>Wire-Break Protection: Incorporated</p> <p>Transient Protection: Per EN 60947-5-2</p> <p>Temperature Drift: <math>\leq \pm 10\%</math></p> <p>Shock: 30 g, 11 ms</p> <p>Vibration: 55 Hz, 1 mm Amplitude in all 3 Planes</p> <p>Repeatability: <math>\leq 2\%</math> of Rated Operating Distance</p>	

We reserve the right to make technical alterations without prior notice.

# Rectangular Inductive Sensors | Q10

## Top Sensing Qpak Housing

Part Number/ ID Number	Features	Embeddable	Sensing Range (mm)	Output	Voltage	Switching Freq. (Hz)	Operating Current (mA)	Operating Temp. (°C)	Protection	Housing	Front Cap/Face	Power LED	Output LED	Cable Length/Jacket	Dimension Drawings	Wiring Diagrams	Spec List
Bi8U-Q10-AN6X2 1662003	Uprox	•	8	3-wire DC NPN	10-30 VDC	250	≤200	-30 to +85	IP67	PBT	PBT	GN	YE	2M/TPU	A	1	A4
Bi8U-Q10-AP6X2 1662001	Uprox	•	8	3-wire DC PNP	10-30 VDC	250	≤200	-30 to +85	IP67	PBT	PBT	GN	YE	2M/TPU	A	2	A4
Bi8U-Q10-AN6X2-V1131 1662004	Uprox	•	8	3-wire DC NPN	10-30 VDC	250	≤200	-30 to +85	IP67	PBT	PBT	GN	YE	--	B	3	A4
Bi8U-Q10-AP6X2-V1131 1662002	Uprox	•	8	3-wire DC PNP	10-30 VDC	250	≤200	-30 to +85	IP67	PBT	PBT	GN	YE	--	B	4	A4
Bi8-Q10-VN6X2 4616410	Comp. Outputs	•	8	4-wire DC NPN	10-30 VDC	250	≤200	-25 to +70	IP67	PBT	PBT	GN	YE	2M/TPU	A	6	A4
Bi8-Q10-VP6X2 4616401	Comp. Outputs	•	8	4-wire DC PNP	10-30 VDC	250	≤200	-25 to +70	IP67	PBT	PBT	GN	YE	2M/TPU	A	7	A4
Bi8-Q10-VP6X2-V1141 4616402	Comp. Outputs	•	8	4-wire DC PNP	10-30 VDC	500	≤200	-25 to +70	IP67	PBT	PBT	GN	YE	--	B	5	A4

We reserve the right to make technical alterations without prior notice.

Rectangular Inductive Sensors

# Rectangular Inductive Sensors | Q12

## Side Sensing Qpak Housing

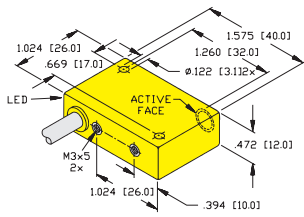
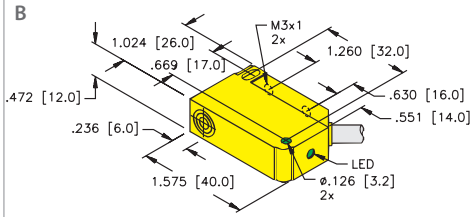
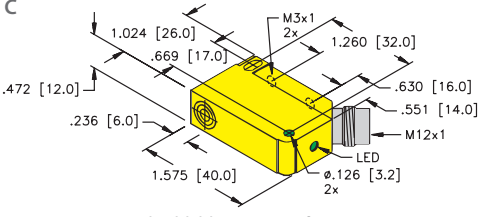
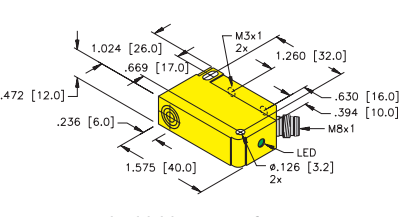
Housing Style	Dimension Drawings	
	<p><b>A</b></p>  <p>12 mm - Embeddable/Nonembeddable, Potted-In Cable</p>	<p><b>B</b></p>  <p>12 mm - Embeddable, Potted-In Cable</p>
<p><b>C</b></p>  <p>12 mm - Embeddable, M12 Eurofast Connection</p>	<p><b>D</b></p>  <p>12 mm - Embeddable, M8 Picofast Connection</p>	

### Wiring Diagrams/Mating Cordsets

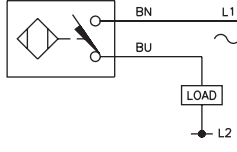
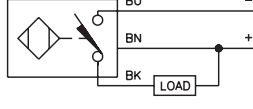
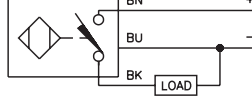
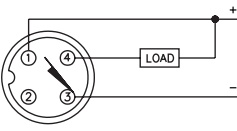
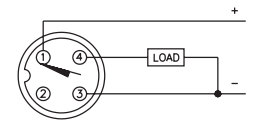
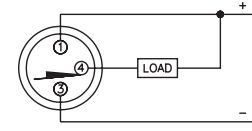
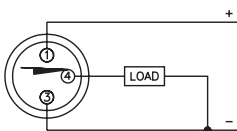
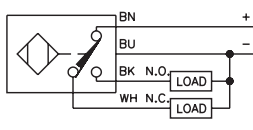
<p><b>1</b></p> 	<p><b>2</b></p> 	<p><b>3</b></p> 
<p><b>4</b></p>  <p>Mating Cordset: RK 4T-*</p>	<p><b>5</b></p>  <p>Mating Cordset: RK 4T-*</p>	<p><b>6</b></p>  <p>Mating Cordset: PKG 3Z-*</p>
<p><b>7</b></p>  <p>Mating Cordset: PKG 3Z-*</p>	<p><b>8</b></p> 	

### A4 3 and 4-wire DC - (AN, RN, AP, RP, VN, VP)

<p>Ripple: <math>\leq 10\%</math></p> <p>Differential Travel (Hysteresis): 3-15% (5% typical)</p> <p>Voltage Drop Across Conducting Sensor: <math>\leq 1.8\text{ V}</math></p> <p>Trigger Current for Short Circuit Protection: <math>\geq 220\text{ mA}</math> on 200 mA Load Current  <math>\geq 170\text{ mA}</math> on 150 mA Load Current  <math>\geq 120\text{ mA}</math> on 100 mA Load Current</p> <p>Off-State (Leakage) Current: <math>\leq 0.1\text{ mA}</math></p> <p>No-Load Current: <math>\leq 15\text{ mA}</math> (Ferrite, Uprox, Rectangular)  <math>\leq 20\text{ mA}</math> (Uprox+, Uprox 3)</p> <p>Time Delay Before Availability: <math>\leq 8\text{ ms}</math></p>	<p>Power-On Effect: Per IEC 947-5-2</p> <p>Reverse Polarity Protection: Incorporated</p> <p>Wire-Break Protection: Incorporated</p> <p>Transient Protection: Per EN 60947-5-2</p> <p>Temperature Drift: <math>\pm 10\%</math></p> <p>Shock: 30 g, 11 ms</p> <p>Vibration: 55 Hz, 1 mm Amplitude in all 3 Planes</p> <p>Repeatability: <math>\leq 2\%</math> of Rated Operating Distance</p>
--	---

### A6 2-wire AC/DC w/o Short-Circuit Protection - (AZ, RZ, FZ)

<p>Line Frequency: <math>\geq 50\text{ Hz}</math>... <math>\leq 60\text{ Hz}</math></p> <p>Differential Travel (Hysteresis): 3-15% (5% typical)</p> <p>Voltage Drop Across Conducting Sensor: <math>\leq 6.0\text{ V}</math></p> <p>Continuous Load Current: AC: <math>\leq 400\text{ mA}</math>; DC: <math>\leq 300\text{ mA}</math>  AC: <math>\leq 100\text{ mA}</math>; DC: <math>\leq 100\text{ mA}</math></p> <p>Off-State (Leakage) Current: <math>\leq 1.7\text{ mA}</math></p> <p>Minimum Load Current: <math>\geq 3.0\text{ mA}</math></p>	<p>Inrush Current: <math>\leq 8\text{ A}</math> (<math>\leq 10\text{ ms}</math> max. 5 Hz)  <math>\leq 1\text{ A}</math> (<math>\leq 10\text{ ms}</math> max. 5 Hz) 12 mm  <math>\leq 0.2\text{ A}</math> (<math>\leq 10\text{ ms}</math> max. 0.2 Hz) 8 mm</p> <p>Power-On Effect: Per IEC 947-5-2</p> <p>Transient Protection: Per EN 60947-5-2</p> <p>Shock: 30 g, 11 ms</p> <p>Vibration: 55 Hz, 1 mm Amplitude, in all 3 Planes</p> <p>Repeatability: <math>\leq 2\%</math> of Rated Operating Distance</p>
--	--

We reserve the right to make technical alterations without prior notice.

## Rectangular Inductive Sensors | Q12

### Side Sensing Qpak Housing

Part Number/ ID Number	Features	Embeddable	Sensing Range (mm)	Output	Voltage	Switching Freq. (Hz)	Operating Current (mA)	Operating Temp. (°C)	Protection	Housing	Front Cap/Face	Power LED	Output LED	Cable Length/Jacket	Dimension Drawings	Wiring Diagrams	Spec List
Bi2-Q12-AZ31X 13100		•	2	2-wire AC	20-250 VAC/10-300 VDC	20	≤100	-25 to +70	IP67	PBT	PBT	N/A	YE	2M/ PVC	A	1	A6
Ni4-Q12-AZ31X 13102			4	2-wire AC	20-250 VAC/10-300 VDC	20	≤100	-25 to +70	IP67	PBT	PBT	N/A	YE	2M/ PVC	A	1	A6
Bi5U-Q12-AN6X2 1635523	Uprox+	•	5	3-wire DC NPN	10-30 VDC	1000	≤200	-25 to +70	IP68	PA 12-GF30	LCP	GN	YE	2M/ TPU	B	2	A4
Bi5U-Q12-AP6X2 1635522	Uprox+	•	5	3-wire DC PNP	10-30 VDC	1000	≤200	-25 to +70	IP68	PA 12-GF30	LCP	GN	YE	2M/ TPU	B	3	A4
Bi5U-Q12-VP6X2 1635533	Uprox+	•	5	4-wire DC PNP	10-30 VDC	1000	≤200	-25 to +70	IP68	PA 12-GF30	PA 12-GF30	GN	YE	2M/ TPU	B	8	A4
Bi5U-Q12-AN6X2-H1141 1635527	Uprox+	•	5	3-wire DC NPN	10-30 VDC	1000	≤200	-25 to +70	IP68	PA 12-GF30	LCP	GN	YE	--	C	4	A4
Bi5U-Q12-AP6X2-H1141 1635526	Uprox+	•	5	3-wire DC PNP	10-30 VDC	1000	≤200	-25 to +70	IP68	PA 12-GF30	LCP	GN	YE	--	C	5	A4
Bi5U-Q12-AN6X2-V1131 1635525	Uprox+	•	5	3-wire DC NPN	10-30 VDC	1000	≤200	-25 to +70	IP68	PA 12-GF30	LCP	GN	YE	--	D	6	A4
Bi5U-Q12-AP6X2-V1131 1635524	Uprox+	•	5	3-wire DC PNP	10-30 VDC	1000	≤200	-25 to +70	IP68	PA 12-GF30	LCP	GN	YE	--	D	7	A4

We reserve the right to make technical alterations without prior notice.

Rectangular Inductive Sensors



# Rectangular Inductive Sensors | Q14

## Top Sensing Qpak Housing

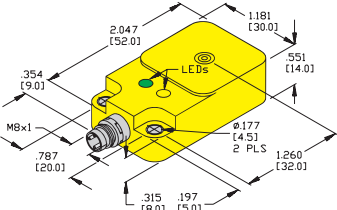
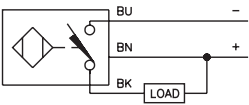
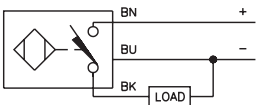
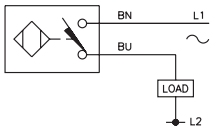
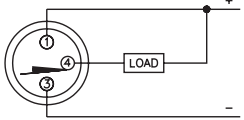
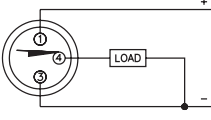
Housing Style	Dimension Drawings	
	<p><b>A</b></p> <p>14 mm - Potted-In Cable</p>	
<p><b>B</b></p>  <p>14 mm - Embeddable/Nonembeddable, M8 Picofast Connector</p>		
Wiring Diagrams/Mating Cordsets		
<p><b>1</b></p> 	<p><b>2</b></p> 	<p><b>3</b></p> 
<p><b>4</b></p>  <p>Mating Cordset: PKG 3M-*</p>	<p><b>5</b></p>  <p>Mating Cordset: PKG 3M-*</p>	
A4 3 and 4-wire DC - (AN, RN, AP, RP, VN, VP)		
<p>Ripple: <math>\leq 10\%</math></p> <p>Differential Travel (Hysteresis): 3-15% (5% typical)</p> <p>Voltage Drop Across Conducting Sensor: <math>\leq 1.8\text{ V}</math></p> <p>Trigger Current for Short Circuit Protection: <math>\geq 220\text{ mA}</math> on 200 mA Load Current  <math>\geq 170\text{ mA}</math> on 150 mA Load Current  <math>\geq 120\text{ mA}</math> on 100 mA Load Current</p> <p>Off-State (Leakage) Current: <math>\leq 0.1\text{ mA}</math></p> <p>No-Load Current: <math>\leq 15\text{ mA}</math> (Ferrite, Uprox, Rectangular)  <math>\leq 20\text{ mA}</math> (Uprox+, Uprox 3)</p> <p>Time Delay Before Availability: <math>\leq 8\text{ ms}</math></p>	<p>Power-On Effect: Per IEC 947-5-2</p> <p>Reverse Polarity Protection: Incorporated</p> <p>Wire-Break Protection: Incorporated</p> <p>Transient Protection: Per EN 60947-5-2</p> <p>Temperature Drift: <math>\pm 10\%</math></p> <p>Shock: 30 g, 11 ms</p> <p>Vibration: 55 Hz, 1 mm Amplitude in all 3 Planes</p> <p>Repeatability: <math>\leq 2\%</math> of Rated Operating Distance</p>	
A5 2-wire AC/DC w/ Short-Circuit Protection - (ADZ, RDZ, FDZ, VDZ)		
<p>Line Frequency: <math>\geq 50\text{ Hz}</math>... <math>\leq 60\text{ Hz}</math></p> <p>Differential Travel (Hysteresis): 3-15% (5% typical)</p> <p>Voltage Drop Across Conducting Sensor: <math>\leq 6.0\text{ V}</math></p> <p>Trigger Current for Short Circuit Protection: AC: <math>\geq 440\text{ mA}</math>; DC: <math>\geq 330\text{ mA}</math>  AC: <math>\geq 120\text{ mA}</math>; DC: <math>\geq 120\text{ mA}</math></p> <p>Continuous Load Current: AC: <math>\leq 400\text{ mA}</math>; DC: <math>\leq 300\text{ mA}</math>  AC: <math>\leq 100\text{ mA}</math>; DC: <math>\leq 100\text{ mA}</math></p> <p>Off-State (Leakage) Current: <math>\leq 1.7\text{ mA}</math> (AC)  <math>\leq 1.5\text{ mA}</math> (DC)</p>	<p>Minimum Load Current: <math>\geq 3.0\text{ mA}</math></p> <p>Inrush Current: <math>\leq 3.0\text{ A}</math> (<math>\leq 20\text{ ms}</math>, max 5 Hz)</p> <p>Power-On Effect: Per IEC 947-5-2</p> <p>Transient Protection: Per EN 60947-5-2</p> <p>Shock: 30 g, 11 ms</p> <p>Vibration: 55 Hz, 1 mm Amplitude, in all 3 Planes</p> <p>Repeatability: <math>\leq 2\%</math> of Rated Operating Distance</p>	

We reserve the right to make technical alterations without prior notice.

# Rectangular Inductive Sensors | Q14

## Top Sensing Qpak Housing

Part Number/ ID Number	Features	Embeddable	Sensing Range (mm)	Output	Voltage	Switching Freq. (Hz)	Operating Current (mA)	Operating Temp. (°C)	Protection	Housing	Front Cap/Face	Power LED	Output LED	Cable Length/Jacket	Dimension Drawings	Wiring Diagrams	Spec List
Bi10U-Q14-AN6X2 1608710	Uprox	•	10	3-wire DC NPN	10-30 VDC	250	≤200	-30 to +85	IP67	PBT	PBT	GN	YE	2M/ TPU	A	1	A4
Bi10U-Q14-AP6X2 1608700	Uprox	•	10	3-wire DC PNP	10-30 VDC	250	≤200	-30 to +85	IP67	PBT	PBT	GN	YE	2M/ TPU	A	2	A4
Bi10U-Q14-AN6X2-V1131 1608510	Uprox	•	10	3-wire DC PNP	10-30 VDC	250	≤200	-30 to +85	IP67	PBT	PBT	GN	YE	--	B	4	A4
Bi10U-Q14-AP6X2-V1131 1608500	Uprox	•	10	3-wire DC PNP	10-30 VDC	250	≤200	-30 to +85	IP67	PBT	PBT	GN	YE	--	B	5	A4
Bi10-Q14-AN6X2 1608320		•	10	3-wire DC NPN	10-30 VDC	250	≤200	-25 to +70	IP67	PBT	PBT	GN	YE	2M/ TPU	A	1	A4
Bi10-Q14-AP6X2 1608720		•	10	3-wire DC PNP	10-30 VDC	250	≤200	-25 to +70	IP67	PBT	PBT	GN	YE	2M/ TPU	A	2	A4
Bi10-Q14-ADZ32X2 4256220		•	10	2-wire AC/DC	20-250 VAC/10-300 VDC	20	≤100	-25 to +70	IP67	PBT	PBT	GN	RD	2M/ TPU	A	3	A5
Bi10-Q14-ADZ32X2/S34 4256225	WFI	•	10	2-wire AC/DC	20-250 VAC/10-300 VDC	20	≤100	-25 to +70	IP67	PBT	PBT	GN	RD	2M/ TPU	A	3	A5
Bi10-Q14-AP6X2-V1131 1608530		•	10	3-wire DC PNP	10-30 VDC	250	≤200	-25 to +70	IP67	PBT	PBT	GN	YE	--	B	5	A4
Ni20-Q14-AP6X2-V1131 4690210			20	3-wire DC PNP	10-30 VDC	250	≤200	-25 to +70	IP67	PBT	PBT	GN	YE	--	B	5	A4
Ni20-Q14-AN6X2 4690220			20	3-wire DC NPN	10-30 VDC	250	≤200	-25 to +70	IP67	PBT	PBT	GN	YE	2M/ TPU	A	1	A4
Ni20-Q14-AP6X2 4690205		•	20	3-wire DC PNP	10-30 VDC	250	≤200	-25 to +70	IP67	PBT	PBT	GN	YE	2M/ TPU	A	2	A4
Ni20-Q14-ADZ32X2 4205410		•	20	2-wire AC/DC	20-250 VAC/10-300 VDC	20	≤100	-25 to +70	IP67	PBT	PBT	GN	RD	2M/ TPU	A	3	A5

We reserve the right to make technical alterations without prior notice.

Rectangular Inductive Sensors

# Rectangular Inductive Sensors | Q20

## Top Sensing Qpak Housing with Potted-in Cable

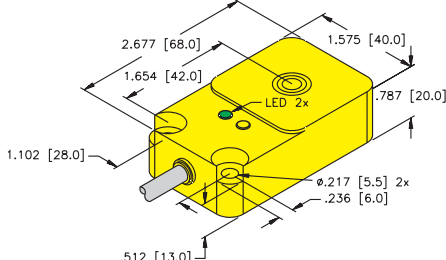
Housing Style	Dimension Drawings
	<p>A</p>  <p>2.677 [68.0] 1.654 [42.0] 1.575 [40.0] 1.102 [28.0] 1.787 [20.0] 4.217 [5.5] 2x .236 [6.0] .512 [13.0]</p> <p>LED 2x</p> <p>20 mm - Embeddable/Nonembeddable, Potted-In Cable</p>

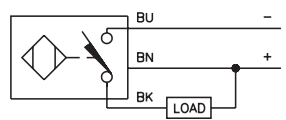
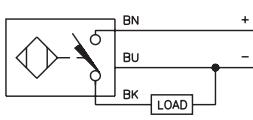
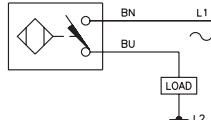
Wiring Diagrams/Mating Cordsets		
<p>1</p> 	<p>2</p> 	<p>3</p> 

A4	3 and 4-wire DC - (AN, RN, AP, RP, VN, VP)	
<p>Ripple: <math>\leq 10\%</math></p> <p>Differential Travel (Hysteresis): 3-15% (5% typical)</p> <p>Voltage Drop Across Conducting Sensor: <math>\leq 1.8\text{ V}</math></p> <p>Trigger Current for Short Circuit Protection: <math>\geq 220\text{ mA}</math> on 200 mA Load Current <math>\geq 170\text{ mA}</math> on 150 mA Load Current <math>\geq 120\text{ mA}</math> on 100 mA Load Current</p> <p>Off-State (Leakage) Current: <math>\leq 0.1\text{ mA}</math></p> <p>No-Load Current: <math>\leq 15\text{ mA}</math> (Ferrite, Uprox, Rectangular) <math>\leq 20\text{ mA}</math> (Uprox+, Uprox 3)</p> <p>Time Delay Before Availability: <math>\leq 8\text{ ms}</math></p>		<p>Power-On Effect: Per IEC 947-5-2</p> <p>Reverse Polarity Protection: Incorporated</p> <p>Wire-Break Protection: Incorporated</p> <p>Transient Protection: Per EN 60947-5-2</p> <p>Temperature Drift: <math>\leq \pm 10\%</math></p> <p>Shock: 30 g, 11 ms</p> <p>Vibration: 55 Hz, 1 mm Amplitude in all 3 Planes</p> <p>Repeatability: <math>\leq 2\%</math> of Rated Operating Distance</p>
A5	2-wire AC/DC w/ Short-Circuit Protection - (ADZ, RDZ, FDZ, VDZ)	
<p>Line Frequency: <math>\geq 50\text{...} \leq 60\text{ Hz}</math></p> <p>Differential Travel (Hysteresis): 3-15% (5% typical)</p> <p>Voltage Drop Across Conducting Sensor: <math>\leq 6.0\text{ V}</math></p> <p>Trigger Current for Short Circuit Protection: AC: <math>\geq 440\text{ mA}</math>; DC: <math>\geq 330\text{ mA}</math> AC: <math>\geq 120\text{ mA}</math>; DC: <math>\geq 120\text{ mA}</math></p> <p>Continuous Load Current: AC: <math>\leq 400\text{ mA}</math>; DC: <math>\leq 300\text{ mA}</math> AC: <math>\leq 100\text{ mA}</math>; DC: <math>\leq 100\text{ mA}</math></p> <p>Off-State (Leakage) Current: <math>\leq 1.7\text{ mA}</math> (AC) <math>\leq 1.5\text{ mA}</math> (DC)</p>		<p>Minimum Load Current: <math>\geq 3.0\text{ mA}</math></p> <p>Inrush Current: <math>\leq 3.0\text{ A}</math> (<math>\leq 20\text{ ms}</math>, max 5 Hz)</p> <p>Power-On Effect: Per IEC 947-5-2</p> <p>Transient Protection: Per EN 60947-5-2</p> <p>Shock: 30 g, 11 ms</p> <p>Vibration: 55 Hz, 1 mm Amplitude in all 3 Planes</p> <p>Repeatability: <math>\leq 2\%</math> of Rated Operating Distance</p>

We reserve the right to make technical alterations without prior notice.

## Rectangular Inductive Sensors | Q20

### Top Sensing Qpak Housing with Potted-in Cable

Part Number/ ID Number	Features	Embeddable	Sensing Range (mm)	Output	Voltage	Switching Freq. (Hz)	Operating Current (mA)	Operating Temp. (°C)	Protection	Housing	Front Cap/Face	Power LED	Output LED	Cable Length/Jacket	Dimension Drawings	Wiring Diagrams	Spec List
Bi15U-Q20-AN6X2 1608810	Uprox	•	15	3-wire DC NPN	10-30 VDC	250	≤200	-30 to +85	IP67	PBT	PBT	GN	YE	2M/TPU	A	1	A4
Bi15U-Q20-AP6X2 1608800	Uprox	•	15	3-wire DC PNP	10-30 VDC	250	≤200	-30 to +85	IP67	PBT	PBT	GN	YE	2M/TPU	A	2	A4
Bi15-Q20-AP6X2 1608300		•	15	3-wire DC PNP	10-30 VDC	250	≤200	-25 to +70	IP67	PBT	PBT	GN	YE	2M/TPU	A	2	A4
Bi15-Q20-ADZ32X2 4256250		•	15	2-wire AC/DC	20-250 VAC/10-300 VDC	20	≤100	-25 to +70	IP67	PBT	PBT	GN	YE	2M/TPU	A	3	A5
Ni25-Q20-AN6X2 1602800			25	3-wire DC NPN	10-30 VDC	250	≤200	-25 to +70	IP67	PBT	PBT	GN	YE	2M/TPU	A	1	A4
Ni25-Q20-AP6X2 1602700			25	3-wire DC PNP	10-30 VDC	250	≤200	-25 to +70	IP67	PBT	PBT	GN	YE	2M/TPU	A	2	A4

We reserve the right to make technical alterations without prior notice.

Rectangular Inductive Sensors

# Rectangular Inductive Sensors | Q20

## Top Sensing Qpak Housing with Integral Connector

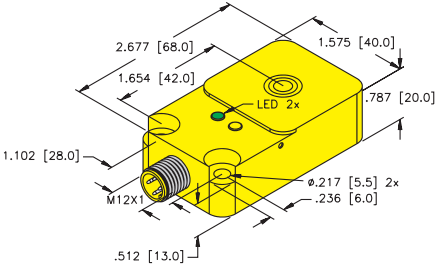
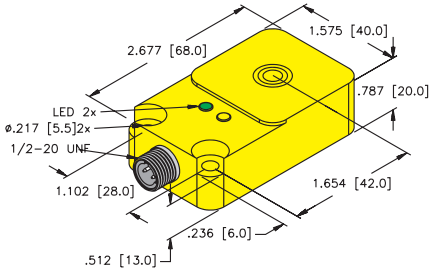
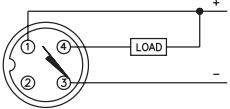
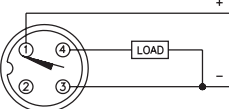
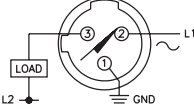
Housing Style	Dimension Drawings	
	<p><b>A</b></p>  <p>20 mm - Embeddable/Nonembeddable, M12 Eurofast Connector</p>	
<p><b>B</b></p>  <p>20 mm - Embeddable, 1/2-20UNF Microfast Connector</p>		
Wiring Diagrams/Mating Cordsets		
<p><b>1</b></p>  <p>Mating Cordset: RK 4T-*</p>	<p><b>2</b></p>  <p>Mating Cordset: RK 4T-*</p>	<p><b>3</b></p>  <p>Mating Cordset: KB 3T-*</p>
A4 3 and 4-wire DC - (AN, RN, AP, RP, VN, VP)		
<p><b>Ripple:</b> <math>\leq 10\%</math></p> <p><b>Differential Travel (Hysteresis):</b> 3-15% (5% typical)</p> <p><b>Voltage Drop Across Conducting Sensor:</b> <math>\leq 1.8\text{ V}</math></p> <p><b>Trigger Current for Short Circuit Protection:</b></p> <ul style="list-style-type: none"> <li><math>\geq 220\text{ mA}</math> on 200 mA Load Current</li> <li><math>\geq 170\text{ mA}</math> on 150 mA Load Current</li> <li><math>\geq 120\text{ mA}</math> on 100 mA Load Current</li> </ul> <p><b>Off-State (Leakage) Current:</b> <math>\leq 0.1\text{ mA}</math></p> <p><b>No-Load Current:</b> <math>\leq 15\text{ mA}</math> (Ferrite, Uprox, Rectangular)</p> <ul style="list-style-type: none"> <li><math>\leq 20\text{ mA}</math> (Uprox+, Uprox 3)</li> </ul> <p><b>Time Delay Before Availability:</b> <math>\leq 8\text{ ms}</math></p>	<p><b>Power-On Effect:</b> Per IEC 947-5-2</p> <p><b>Reverse Polarity Protection:</b> Incorporated</p> <p><b>Wire-Break Protection:</b> Incorporated</p> <p><b>Transient Protection:</b> Per EN 60947-5-2</p> <p><b>Temperature Drift:</b> <math>\leq \pm 10\%</math></p> <p><b>Shock:</b> 30 g, 11 ms</p> <p><b>Vibration:</b> 55 Hz, 1 mm Amplitude in all 3 Planes</p> <p><b>Repeatability:</b> <math>\leq 2\%</math> of Rated Operating Distance</p>	
A5 2-wire AC/DC w/ Short-Circuit Protection - (ADZ, RDZ, FDZ, VDZ)		
<p><b>Line Frequency:</b> <math>\geq 50\text{...} \leq 60\text{ Hz}</math></p> <p><b>Differential Travel (Hysteresis):</b> 3-15% (5% typical)</p> <p><b>Voltage Drop Across Conducting Sensor:</b> <math>\leq 6.0\text{ V}</math></p> <p><b>Trigger Current for Short Circuit Protection:</b> AC: <math>\geq 440\text{ mA}</math>; DC: <math>\geq 330\text{ mA}</math></p> <ul style="list-style-type: none"> <li>AC: <math>\geq 120\text{ mA}</math>; DC: <math>\geq 120\text{ mA}</math></li> </ul> <p><b>Continuous Load Current:</b> AC: <math>\leq 400\text{ mA}</math>; DC: <math>\leq 300\text{ mA}</math></p> <ul style="list-style-type: none"> <li>AC: <math>\leq 100\text{ mA}</math>; DC: <math>\leq 100\text{ mA}</math></li> </ul> <p><b>Off-State (leakage) Current:</b> <math>\leq 1.7\text{ mA}</math> (AC)</p> <ul style="list-style-type: none"> <li><math>\leq 1.5\text{ mA}</math> (DC)</li> </ul>	<p><b>Minimum Load Current:</b> <math>\geq 3.0\text{ mA}</math></p> <p><b>Inrush Current:</b> <math>\leq 3.0\text{ A}</math> (<math>\leq 20\text{ ms}</math>, max 5 Hz)</p> <p><b>Power-On Effect:</b> Per IEC 947-5-2</p> <p><b>Transient Protection:</b> Per EN 60947-5-2</p> <p><b>Shock:</b> 30 g, 11 ms</p> <p><b>Vibration:</b> 55 Hz, 1 mm Amplitude, in all 3 Planes</p> <p><b>Repeatability:</b> <math>\leq 2\%</math> of Rated Operating Distance</p>	

We reserve the right to make technical alterations without prior notice.

## Rectangular Inductive Sensors | Q20

### Top Sensing Qpak Housing with Integral Connector

Part Number/ ID Number	Features	Embeddable	Sensing Range (mm)	Output	Voltage	Switching Freq. (Hz)	Operating Current (mA)	Operating Temp. (°C)	Protection	Housing	Front Cap/Face	Power LED	Output LED	Dimension Drawings	Wiring Diagrams	Spec List
Bi15U-Q20-AN6X2-H1141 1608610	Uprox	•	15	3-wire DC NPN	10-30 VDC	250	≤200	-30 to +85	IP67	PBT	PBT	GN	YE	A	1	A4
Bi15U-Q20-AP6X2-H1141 1608600	Uprox	•	15	3-wire DC PNP	10-30 VDC	250	≤200	-30 to +85	IP67	PBT	PBT	GN	YE	A	2	A4
Bi15-Q20-AN6X2-H1141 1608315		•	15	3-wire DC NPN	10-30 VDC	250	≤200	-25 to +70	IP67	PBT	PBT	GN	YE	A	1	A4
Bi15-Q20-AP6X2-H1141 1608305		•	15	3-wire DC PNP	10-30 VDC	250	≤200	-25 to +70	IP67	PBT	PBT	GN	YE	A	2	A4
Bi15-Q20-ADZ32X2-B3131 4256251		•	15	2-wire AC/DC	20-250 VAC/10-300 VDC	20	≤100	-25 to +70	IP67	PBT	PBT	GN	YE	B	3	A5
Ni25-Q20-AN6X2-H1141 1602802			25	3-wire DC NPN	10-30 VDC	250	≤200	-25 to +70	IP67	PBT	PBT	GN	YE	A	1	A4
Ni25-Q20-AP6X2-H1141 1602702			25	3-wire DC PNP	10-30 VDC	250	≤200	-25 to +70	IP67	PBT	PBT	GN	YE	A	2	A4

We reserve the right to make technical alterations without prior notice.

Rectangular Inductive Sensors

# Rectangular Inductive Sensors | Q18, Q25, & Q30

## Side Sensing Qpak Housing

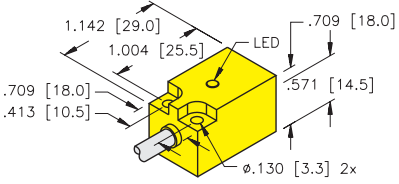
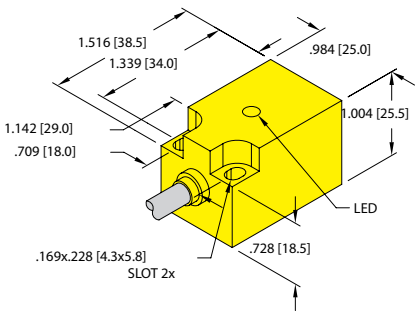
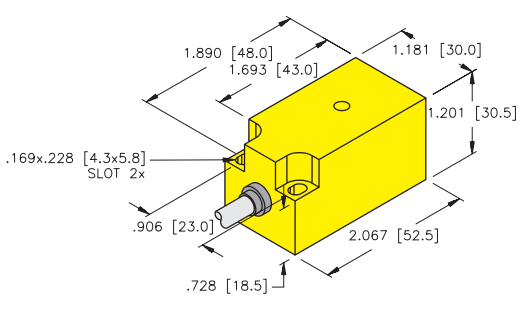
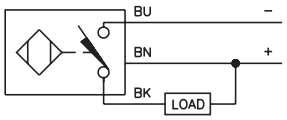
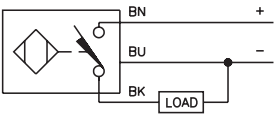
Housing Style	Dimension Drawings
	<p><b>A</b></p>  <p>18 mm - Nonembeddable, Potted-In Cable</p>
<p><b>B</b></p>  <p>25 mm - Nonembeddable, Potted-In Cable</p>	<p><b>C</b></p>  <p>30 mm - Nonembeddable, Potted-In Cable</p>
Wiring Diagrams/Mating Cordsets	
<p><b>1</b></p> 	<p><b>2</b></p> 
A4 3 and 4-wire DC - (AN, RN, AP, RP, VN, VP)	
<p>Ripple: ≤10%</p> <p>Differential Travel (Hysteresis): 3-15% (5% typical)</p> <p>Voltage Drop Across Conducting Sensor: ≤1.8 V</p> <p>Trigger Current for Short Circuit Protection: ≥220 mA on 200 mA Load Current          ≥170 mA on 150 mA Load Current          ≥120 mA on 100 mA Load Current</p> <p>Off-State (Leakage) Current: ≤0.1 mA</p> <p>No-Load Current: ≤15 mA (Ferrite, Uprox, Rectangular)          ≤20 mA (Uprox+, Uprox 3)</p> <p>Time Delay Before Availability: ≤8 ms</p>	<p>Power-On Effect: Per IEC 947-5-2</p> <p>Reverse Polarity Protection: Incorporated</p> <p>Wire-Break Protection: Incorporated</p> <p>Transient Protection: Per EN 60947-5-2</p> <p>Temperature Drift: ≤±10%</p> <p>Shock: 30 g, 11 ms</p> <p>Vibration: 55 Hz, 1 mm Amplitude in all 3 Planes</p> <p>Repeatability: ≤2% of Rated Operating Distance</p>

We reserve the right to make technical alterations without prior notice.

## Rectangular Inductive Sensors | Q18, Q25, & Q30

### Side Sensing Qpak Housing

Part Number/ ID Number	Sensing Range (mm)	Output	Voltage	Switching Freq. (Hz)	Operating Current (mA)	Operating Temp. (°C)	Protection	Housing	Front Cap/Face	Power LED	Output LED	Cable Length/Jacket	Dimension Drawings	Wiring Diagrams	Spec List
Ni5-Q18-AN6X 4614607	5	3-wire DC NPN	10-30 VDC	500	≤200	-25 to +70	IP67	PBT	PBT	N/A	YE	2M/PVC	A	1	A4
Ni5-Q18-AP6X 4614606	5	3-wire DC PNP	10-30 VDC	500	≤200	-25 to +70	IP67	PBT	PBT	N/A	YE	2M/PVC	A	2	A4
Ni10-Q25-AN6X 4652330	10	3-wire DC NPN	10-30 VDC	500	≤200	-25 to +70	IP67	PBT	PBT	N/A	YE	2M/PVC	B	1	A4
Ni10-Q25-AP6X 4652225	10	3-wire DC PNP	10-30 VDC	500	≤200	-25 to +70	IP67	PBT	PBT	N/A	YE	2M/PVC	B	2	A4
Ni15-Q30-AN6X 4659330	15	3-wire DC NPN	10-30 VDC	500	≤200	-25 to +70	IP67	PBT	PBT	N/A	YE	2M/PVC	C	1	A4
Ni15-Q30-AP6X 4659325	15	3-wire DC PNP	10-30 VDC	500	≤200	-25 to +70	IP67	PBT	PBT	N/A	YE	2M/PVC	C	2	A4

We reserve the right to make technical alterations without prior notice.

Rectangular Inductive Sensors



# Rectangular Inductive Sensors | CA40

## Rotatable Sensing Head with Metal Housing

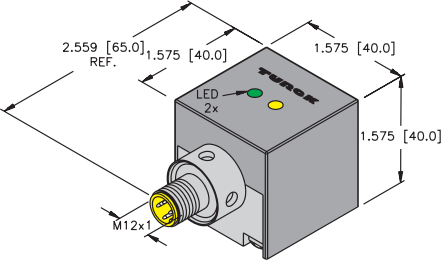
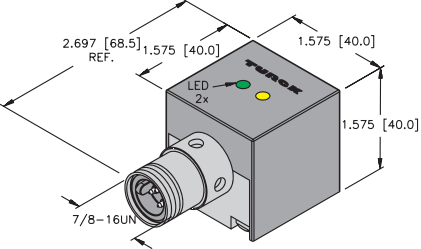
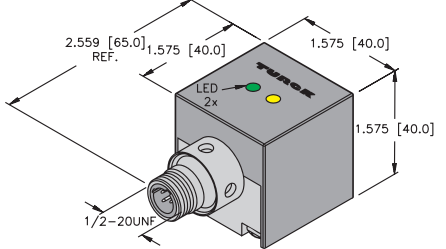
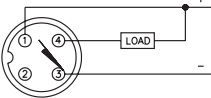
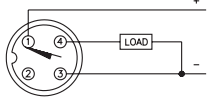
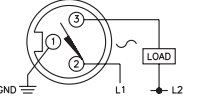
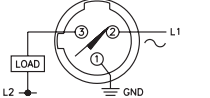
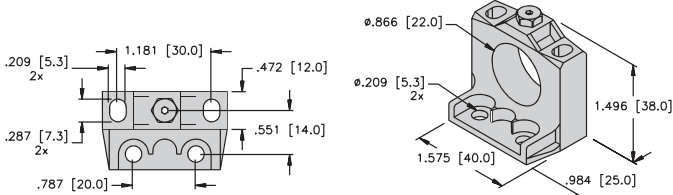
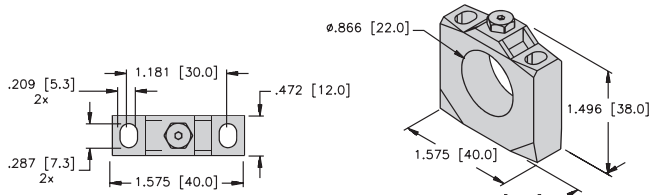
Housing Style	Dimension Drawings		
	<p><b>A</b></p>  <p>CA40 - Embeddable, Eurofast Connector</p>		
<p><b>B</b></p>  <p>CA40 - Embeddable, Minifast Connector</p>	<p><b>C</b></p>  <p>CA40 - Embeddable, Microfast Connector</p>		
Wiring Diagrams/Mating Cordsets			
<p><b>1</b></p>  <p>Mating Cordset: RK 4T-*</p>	<p><b>2</b></p>  <p>Mating Cordset: RK 4T-*</p>	<p><b>3</b></p>  <p>Mating Cordset: RKM 30-*M</p>	<p><b>4</b></p>  <p>Mating Cordset: KB 3T-*</p>
A4 3 and 4-wire DC - (AN, RN, AP, RP, VN, VP)			
<p>Ripple: <math>\leq 10\%</math></p> <p>Differential Travel (Hysteresis): 3-15% (5% typical)</p> <p>Voltage Drop Across Conducting Sensor: <math>\leq 1.8\text{ V}</math></p> <p>Trigger Current for Short Circuit Protection: <math>\geq 220\text{ mA}</math> on 200 mA Load Current  <math>\geq 170\text{ mA}</math> on 150 mA Load Current  <math>\geq 120\text{ mA}</math> on 100 mA Load Current</p> <p>Off-State (Leakage) Current: <math>\leq 0.1\text{ mA}</math></p> <p>No-Load Current: <math>\leq 15\text{ mA}</math> (Ferrite, Uprox, Rectangular)  <math>\leq 20\text{ mA}</math> (Uprox+, Uprox 3)</p> <p>Time Delay Before Availability: <math>\leq 8\text{ ms}</math></p>	<p>Power-On Effect: Per IEC 947-5-2</p> <p>Reverse Polarity Protection: Incorporated</p> <p>Wire-Break Protection: Incorporated</p> <p>Transient Protection: Per EN 60947-5-2</p> <p>Temperature Drift: <math>\pm 10\%</math></p> <p>Shock: 30 g, 11 ms</p> <p>Vibration: 55 Hz, 1 mm Amplitude in all 3 Planes</p> <p>Repeatability: <math>\leq 2\%</math> of Rated Operating Distance</p>		
A5 2-wire AC/DC w/ Short-Circuit Protection - (ADZ, RDZ, FDZ, VDZ)			
<p>Line Frequency: <math>\geq 50\text{...} \leq 60\text{ Hz}</math></p> <p>Differential Travel (Hysteresis): 3-15% (5% typical)</p> <p>Voltage Drop Across Conducting Sensor: <math>\leq 6.0\text{ V}</math></p> <p>Trigger Current for Short Circuit Protection: AC: <math>\geq 440\text{ mA}</math>; DC: <math>\geq 330\text{ mA}</math>  AC: <math>\geq 120\text{ mA}</math>; DC: <math>\geq 120\text{ mA}</math></p> <p>Continuous Load Current: AC: <math>\leq 400\text{ mA}</math>; DC: <math>\leq 300\text{ mA}</math>  AC: <math>\leq 100\text{ mA}</math>; DC: <math>\leq 100\text{ mA}</math></p> <p>Off-State (leakage) Current: <math>\leq 1.7\text{ mA}</math> (AC)  <math>\leq 1.5\text{ mA}</math> (DC)</p>	<p>Minimum Load Current: <math>\geq 3.0\text{ mA}</math></p> <p>Inrush Current: <math>\leq 3.0\text{ A}</math> (<math>\leq 20\text{ ms}</math>, max 5 Hz)</p> <p>Power-On Effect: Per IEC 947-5-2</p> <p>Transient Protection: Per EN 60947-5-2</p> <p>Shock: 30 g, 11 ms</p> <p>Vibration: 55 Hz, 1 mm Amplitude, in all 3 Planes</p> <p>Repeatability: <math>\leq 2\%</math> of Rated Operating Distance</p>		
BS 2.1 Mounting Bracket	BS 2.0 Mounting Bracket		
			

We reserve the right to make technical alterations without prior notice.

## Rectangular Inductive Sensors | CA40

### Rotatable Sensing Head with Metal Housing

Part Number/ ID Number	Features	Embeddable	Sensing Range (mm)	Output	Voltage	Switching Freq. (Hz)	Operating Current (mA)	Operating Temp. (°C)	Protection	Housing	Front Cap/Face	Power LED	Output LED	Dimension Drawings	Wiring Diagrams	Spec List
<b>Bi20U-CA40-AN6X2-H1141 W/BS2.1</b> 1627390	Uprox	•	20	3-wire DC NPN	10-30 VDC	250	≤200	0 to +70	IP67	AL	TP	GN	YE	A	1	A4
<b>Bi20U-CA40-AP6X2-H1141 W/BS2.1</b> 1627290	Uprox	•	20	3-wire DC PNP	10-30 VDC	250	≤200	0 to +70	IP67	AL	TP	GN	YE	A	2	A4
<b>Bi20U-CA40-AP6X2-H1141/S1590 W/BS2.0</b> 1627297	Weldguard®	•	20	3-wire DC PNP	10-30 VDC	250	≤200	0 to +70	IP67	AL	WG	GN	YE	A	2	A4
<b>Bi20U-CA40-ADZ30X2-B1131 W/BS2.1</b> 4283290	Uprox	•	20	2-wire AC/DC	20-250 VAC/10-300 VDC	10	≤400/300	-30 to +85	IP67	AL	TP	GN	YE	B	3	A5
<b>Bi20U-CA40-ADZ30X2-B3131 W/BS2.1</b> 4283292	Uprox	•	20	2-wire AC/DC	20-250 VAC/10-300 VDC	10	≤400/300	-30 to +85	IP67	AL	TP	GN	YE	C	4	A5

We reserve the right to make technical alterations without prior notice.

Rectangular Inductive Sensors

# Rectangular Inductive Sensors | CK40

## Rotatable Sensing Head with 2 and 3-wire DC Outputs

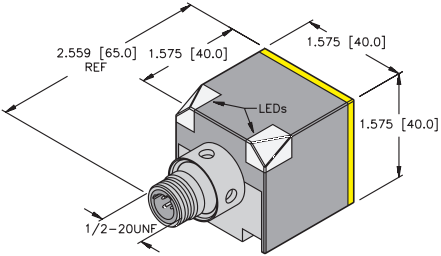
Housing Style	Dimension Drawings
	<p data-bbox="836 336 853 357">A</p>  <p data-bbox="954 599 1404 620">CK40 - Embeddable/Nonembeddable, Eurofast Connector</p>

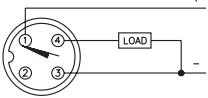
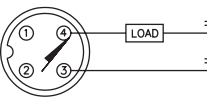
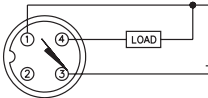
Wiring Diagrams/Mating Cordsets		
<p data-bbox="131 685 147 707">1</p>  <p data-bbox="257 832 446 853">Mating Cordset: RK 4T.*</p>	<p data-bbox="593 685 609 707">2</p>  <p data-bbox="719 832 908 853">Mating Cordset: RK 4.2T.*</p>	<p data-bbox="1063 685 1080 707">3</p>  <p data-bbox="1197 832 1387 853">Mating Cordset: RK 4T.*</p>

A2	2-wire DC - (AD, RD, AG)	
<p data-bbox="425 922 564 944">Ripple: <math>\leq 10\%</math></p> <p data-bbox="240 950 665 972">Differential Travel (Hysteresis): 3-15% (5% typical)</p> <p data-bbox="156 978 727 1000">Voltage Drop Across Conducting Sensor: Non-polarized (AD) &lt;5.0 V</p> <p data-bbox="514 1006 682 1028">Polarized (AG) <math>\leq 4.2</math> V</p> <p data-bbox="136 1034 589 1056">Trigger Current for Short Circuit Protection: <math>\geq 120</math> mA</p> <p data-bbox="290 1062 581 1084">Minimum Load Current: <math>\geq 3.0</math> mA</p>	<p data-bbox="937 922 1265 944">Off-State (Leakage) Current: <math>\leq 0.8</math> mA</p> <p data-bbox="1029 950 1320 972">Power-On Effect: Per IEC 947-5-2</p> <p data-bbox="996 978 1337 1000">Transient Protection: Per EN 60947-5-2</p> <p data-bbox="1113 1006 1286 1028">Shock: 30 g, 11 ms</p> <p data-bbox="1080 1034 1505 1056">Vibration: 55 Hz, 1 mm Amplitude in all 3 Planes</p> <p data-bbox="1046 1062 1466 1084">Repeatability: <math>\leq 2\%</math> of Rated Operating Distance</p>	

A4	3 and 4-wire DC - (AN, RN, AP, RP, VN, VP)	
<p data-bbox="425 1149 564 1170">Ripple: <math>\leq 10\%</math></p> <p data-bbox="240 1177 665 1198">Differential Travel (Hysteresis): 3-15% (5% typical)</p> <p data-bbox="156 1205 564 1226">Voltage Drop Across Conducting Sensor: <math>\leq 1.8</math> V</p> <p data-bbox="136 1233 791 1254">Trigger Current for Short Circuit Protection: <math>\geq 220</math> mA on 200 mA Load Current</p> <p data-bbox="290 1261 791 1282"><math>\geq 170</math> mA on 150 mA Load Current</p> <p data-bbox="290 1289 791 1310"><math>\geq 120</math> mA on 100 mA Load Current</p> <p data-bbox="257 1317 581 1338">Off-State (Leakage) Current: <math>\leq 0.1</math> mA</p> <p data-bbox="341 1345 808 1366">No-Load Current: <math>\leq 15</math> mA (Ferrite, Uprox, Rectangular)</p> <p data-bbox="341 1373 727 1394"><math>\leq 20</math> mA (Uprox+, Uprox 3)</p> <p data-bbox="240 1401 564 1422">Time Delay Before Availability: <math>\leq 8</math> ms</p>	<p data-bbox="1029 1149 1320 1170">Power-On Effect: Per IEC 947-5-2</p> <p data-bbox="945 1177 1169 1198">Reverse Polarity Protection: Incorporated</p> <p data-bbox="979 1205 1303 1226">Wire-Break Protection: Incorporated</p> <p data-bbox="996 1233 1337 1254">Transient Protection: Per EN 60947-5-2</p> <p data-bbox="1013 1261 1253 1282">Temperature Drift: <math>\leq \pm 10\%</math></p> <p data-bbox="1113 1289 1286 1310">Shock: 30 g, 11 ms</p> <p data-bbox="1080 1317 1505 1338">Vibration: 55 Hz, 1 mm Amplitude in all 3 Planes</p> <p data-bbox="1046 1345 1466 1366">Repeatability: <math>\leq 2\%</math> of Rated Operating Distance</p>	

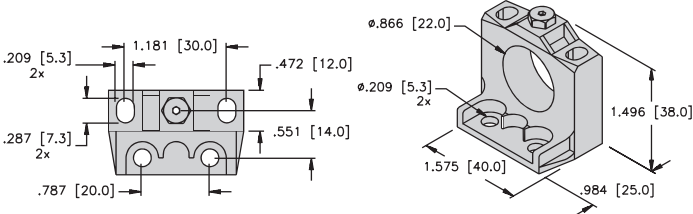
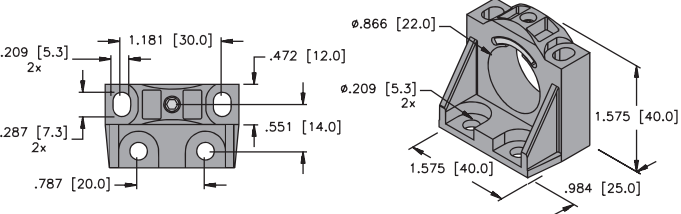
BS 2.1 Mounting Bracket	BS 4 Mounting Bracket
	

We reserve the right to make technical alterations without prior notice.

# Rectangular Inductive Sensors | CK40

## Rotatable Sensing Head with 2 and 3-wire DC Outputs

Part Number/ ID Number	Features	Embeddable	Sensing Range (mm)	Output	Voltage	Switching Freq. (Hz)	Operating Current (mA)	Operating Temp. (°C)	Protection	Housing	Front Cap/Face	Power LED	Output LED	Dimension Drawings	Wiring Diagrams	Spec List
Bi15U-CK40-AN6X2-H1141 W/BS2.1 1625690	Uprox	•	15	3-wire DC NPN	10-30 VDC	250	≤200	-30 to +85	IP68	PBT	PBT	GN	YE	A	3	A4
Bi15U-CK40-AP6X2-H1141 W/BS2.1 1625689	Uprox	•	15	3-wire DC PNP	10-30 VDC	250	≤200	-30 to +85	IP68	PBT	PBT	GN	YE	A	1	A4
Bi15-CK40-AN6X2-H1141 W/BS2.1 1625190		•	15	3-wire DC NPN	10-30 VDC	150	≤200	-25 to +70	IP67	PBT	PBT	GN	YE	A	3	A4
Bi15-CK40-AP6X2-H1141 W/BS2.1 1625090		•	15	3-wire DC PNP	10-30 VDC	150	≤200	-25 to +70	IP67	PBT	PBT	GN	YE	A	1	A4
Bi15-CK40-AD4X-H1141 W/BS2.1 4465090		•	15	2-wire DC	10-65 VDC	150	≤100	-25 to +70	IP67	PBT	PBT	GN	YE	A	2	A2
Bi20U-CK40-AN6X2-H1141 1627231	Uprox+	•	20	3-wire DC NPN	10-30 VDC	250	≤200	-30 to +85	IP68	PBT	PBT	GN	YE	A	3	A4
Bi20U-CK40-AP6X2-H1141 W/BS2.1 1627288	Uprox+	•	20	3-wire DC PNP	10-30 VDC	250	≤200	-30 to +85	IP68	PBT	PBT	GN	YE	A	1	A4
Bi30U-CK40-AN6X2-H1141 1625820	Uprox+	•	30	3-wire DC NPN	10-30 VDC	250	≤200	-10 to +60	IP68	PBT	PBT	GN	YE	A	3	A4
Bi30U-CK40-AP6X2-H1141 1625829	Uprox+	•	30	3-wire DC PNP	10-30 VDC	250	≤200	-10 to +60	IP68	PBT	PBT	GN	YE	A	1	A4
Ni20-CK40-AN6X2-H1141 W/BS2.1 1625390			20	3-wire DC NPN	10-30 VDC	150	≤200	-25 to +70	IP67	PBT	PBT	GN	YE	A	3	A4
Ni20-CK40-AP6X2-H1141 W/BS2.1 1625290			20	3-wire DC PNP	10-30 VDC	150	≤200	-25 to +70	IP67	PBT	PBT	GN	YE	A	1	A4
Ni20-CK40-AD4X-H1141 W/BS2.1 4465290			20	2-wire DC	10-65 VDC	200	≤100	-25 to +70	IP67	PBT	PBT	GN	YE	A	2	A2
Ni25U-CK40-AN6X2-H1141 W/BS2.1 1625789	Uprox		25	3-wire DC NPN	10-30 VDC	250	≤200	-30 to +85	IP68	PBT	PBT	GN	YE	A	3	A4
Ni25U-CK40-AP6X2-H1141 W/BS2.1 1625790	Uprox		25	3-wire DC PNP	10-30 VDC	250	≤200	-30 to +85	IP68	PBT	PBT	GN	YE	A	1	A4
Ni35U-CK40-AP6X2-H1141 1625800	Uprox		35	3-wire DC PNP	10-30 VDC	250	≤200	-30 to +85	IP67	PBT	PBT	GN	YE	A	1	A4
Ni35U-CK40-AN6X2-H1141 1625810	Uprox		35	3-wire DC NPN	10-30 VDC	250	≤200	-30 to +85	IP67	PBT	PBT	GN	YE	A	3	A4
Ni50U-CK40-AN6X2-H1141 1625823	Uprox+		50	3-wire DC NPN	10-30 VDC	250	≤200	-25 to +70	IP68	PBT	PBT	GN	YE	A	3	A4
Ni50U-CK40-AP6X2-H1141 1625868	Uprox+		50	3-wire DC PNP	10-30 VDC	250	≤200	-25 to +70	IP68	PBT	PBT	GN	YE	A	1	A4

We reserve the right to make technical alterations without prior notice.

Rectangular Inductive Sensors

# Rectangular Inductive Sensors | CK40

## Rotatable Sensing Head with Complementary Outputs

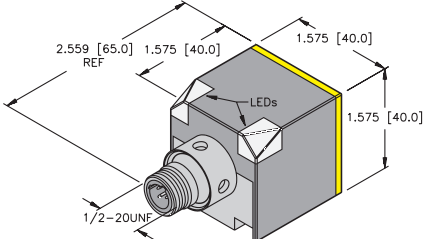
Housing Style	Dimension Drawings
	<p>A</p>  <p>CK40 - Embeddable/Nonembeddable, Eurofast Connector</p>

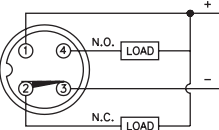
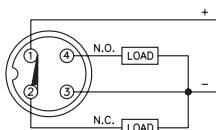
Wiring Diagrams/Mating Cordsets	
<p>1</p>  <p>Mating Cordset: RK 4.4T-*</p>	<p>2</p>  <p>Mating Cordset: RK 4.4T-*</p>

A4 3 and 4-wire DC - (AN, RN, AP, RP, VN, VP)	
<p>Ripple: <math>\leq 10\%</math></p> <p>Differential Travel (Hysteresis): 3-15% (5% typical)</p> <p>Voltage Drop Across Conducting Sensor: <math>\leq 1.8\text{ V}</math></p> <p>Trigger Current for Short Circuit Protection: <math>\geq 220\text{ mA}</math> on 200 mA Load Current  <math>\geq 170\text{ mA}</math> on 150 mA Load Current  <math>\geq 120\text{ mA}</math> on 100 mA Load Current</p> <p>Off-State (Leakage) Current: <math>\leq 0.1\text{ mA}</math></p> <p>No-Load Current: <math>\leq 15\text{ mA}</math> (Ferrite, Uprox, Rectangular)  <math>\leq 20\text{ mA}</math> (Uprox+, Uprox 3)</p> <p>Time Delay Before Availability: <math>\leq 8\text{ ms}</math></p>	<p>Power-On Effect: Per IEC 947-5-2</p> <p>Reverse Polarity Protection: Incorporated</p> <p>Wire-Break Protection: Incorporated</p> <p>Transient Protection: Per EN 60947-5-2</p> <p>Temperature Drift: <math>\leq \pm 10\%</math></p> <p>Shock: 30 g, 11 ms</p> <p>Vibration: 55 Hz, 1 mm Amplitude in all 3 Planes</p> <p>Repeatability: <math>\leq 2\%</math> of Rated Operating Distance</p>

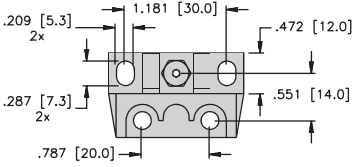
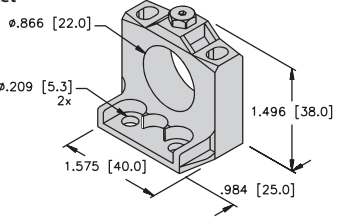
BS 2.1 Mounting Bracket	
	

We reserve the right to make technical alterations without prior notice.

## Rectangular Inductive Sensors | CK40

### Rotatable Sensing Head with Complementary Outputs

Part Number/ ID Number	Features	Embeddable	Sensing Range (mm)	Output	Voltage	Switching Freq. (Hz)	Operating Current (mA)	Operating Temp. (°C)	Protection	Housing	Front Cap/Face	Power LED	Output LED	Dimension Drawings	Wiring Diagrams	Spec List
Bi15-CK40-VN4X2-H1141 W/BS2.1 1550190	Comp. Outputs	•	15	4-wire DC NPN	10-65 VDC	250	≤200	-25 to +70	IP67	PBT	PBT	GN	YE	A	1	A4
Bi15-CK40-VP4X2-H1141 W/BS2.1 1550091	Comp. Outputs	•	15	4-wire DC PNP	10-65 VDC	250	≤200	-25 to +70	IP67	PBT	PBT	GN	YE	A	2	A4
Ni20-CK40-VN4X2-H1141 W/BS2.1 1550390	Comp. Outputs		20	4-wire DC NPN	10-65 VDC	250	≤200	-25 to +70	IP67	PBT	PBT	GN	YE	A	1	A4
Ni20-CK40-VP4X2-H1141 W/BS2.1 1550290	Comp. Outputs		20	4-wire DC PNP	10-65 VDC	250	≤200	-25 to +70	IP67	PBT	PBT	GN	YE	A	2	A4
Ni35U-CK40-VP6X2-H1141 1625815	Uprox, Comp. Outputs		35	4-wire DC PNP	10-30 VDC	250	≤200	-25 to +70	IP67	PBT	PBT	GN	YE	A	2	A4
Ni50U-CK40-VN4X2-H1141 1625806	Uprox+, Comp. Outputs		50	4-wire DC NPN	10-65 VDC	250	≤200	-25 to +70	IP68	PBT	PBT	GN	YE	A	1	A4
Ni50U-CK40-VP4X2-H1141 1538302	Uprox+, Comp. Outputs		50	4-wire DC PNP	10-65 VDC	250	≤200	-25 to +70	IP68	PBT	PBT	GN	YE	A	2	A4

We reserve the right to make technical alterations without prior notice.

Rectangular Inductive Sensors

# Rectangular Inductive Sensors | CK40

## Rotatable Sensing Head with AC/DC Outputs

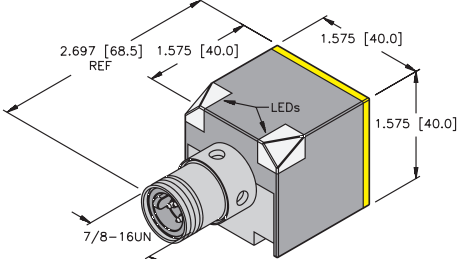
Housing Style	Dimension Drawings
	<p>A</p>  <p>CK40 - Embeddable/Nonembeddable, Minifast Connector</p>

B

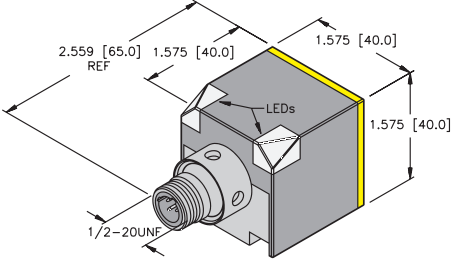

CK40 - Embeddable/Nonembeddable, Microfast Connector

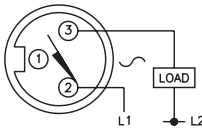
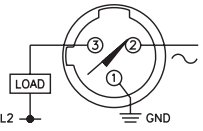
Wiring Diagrams/Mating Cordsets	
<p>1</p>  <p>Mating Cordset: RKM 30-*M</p>	<p>2</p>  <p>Mating Cordset: KB 3T-*</p>

A5 2-wire AC/DC w/ Short-Circuit Protection - (ADZ, RDZ, FDZ, VDZ)	
<p>Line Frequency: <math>\geq 50 \dots \leq 60</math> Hz</p> <p>Differential Travel (Hysteresis): 3-15% (5% typical)</p> <p>Voltage Drop Across Conducting Sensor: <math>\leq 6.0</math> V</p> <p>Trigger Current for Short Circuit Protection: AC: <math>\geq 440</math> mA; DC: <math>\geq 330</math> mA</p> <p>Continuous Load Current: AC: <math>\leq 400</math> mA; DC: <math>\leq 300</math> mA</p> <p>Off-State (Leakage) Current: <math>\leq 1.7</math> mA (AC)</p> <p><math>\leq 1.5</math> mA (DC)</p>	<p>Minimum Load Current: <math>\geq 3.0</math> mA</p> <p>Inrush Current: <math>\leq 3.0</math> A (<math>\leq 20</math> ms, max 5 Hz)</p> <p>Power-On Effect: Per IEC 947-5-2</p> <p>Transient Protection: Per EN 60947-5-2</p> <p>Shock: 30 g, 11 ms</p> <p>Vibration: 55 Hz, 1 mm Amplitude, in all 3 Planes</p> <p>Repeatability: <math>\leq 2\%</math> of Rated Operating Distance</p>

A6 2-wire AC/DC w/o Short-Circuit Protection - (AZ, RZ, FZ)	
<p>Line Frequency: <math>\geq 50 \dots \leq 60</math> Hz</p> <p>Differential Travel (Hysteresis): 3-15% (5% typical)</p> <p>Voltage Drop Across Conducting Sensor: <math>\leq 6.0</math> V</p> <p>Continuous Load Current: AC: <math>\leq 400</math> mA; DC: <math>\leq 300</math> mA</p> <p>Off-State (Leakage) Current: <math>\leq 1.7</math> mA</p> <p>Minimum Load Current: <math>\geq 3.0</math> mA</p>	<p>Inrush Current: <math>\leq 8</math> A (<math>\leq 10</math>ms max. 5 Hz)</p> <p><math>\leq 1</math> A (<math>\leq 10</math> ms max. 5 Hz) 12 mm</p> <p><math>\leq 0.2</math> A (<math>\leq 10</math> ms max. 0.2 Hz) 8 mm</p> <p>Power-On Effect: Per IEC 947-5-2</p> <p>Transient Protection: Per EN 60947-5-2</p> <p>Shock: 30 g, 11 ms</p> <p>Vibration: 55 Hz, 1 mm Amplitude, in all 3 Planes</p> <p>Repeatability: <math>\leq 2\%</math> of Rated Operating Distance</p>

**BS 2.1 Mounting Bracket**

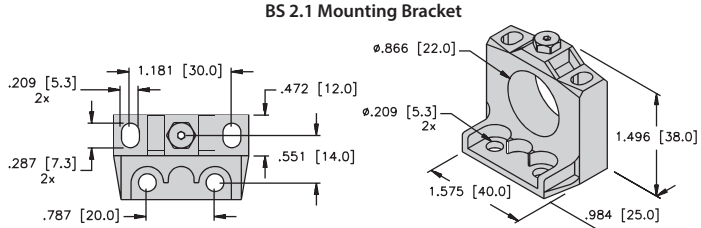

**BS 4 Mounting Bracket**

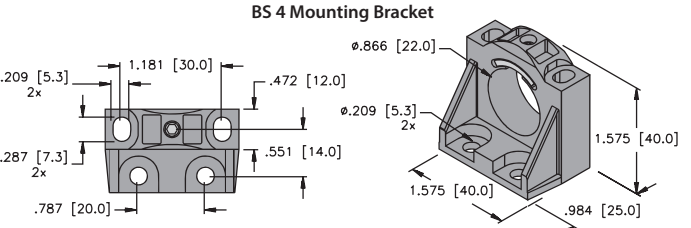

We reserve the right to make technical alterations without prior notice.

# Rectangular Inductive Sensors | CK40

## Rotatable Sensing Head with AC/DC Outputs

Part Number/ ID Number	Features	Embeddable	Sensing Range (mm)	Output	Voltage	Switching Freq. (Hz)	Operating Current (mA)	Operating Temp. (°C)	Protection	Housing	Front Cap/Face	Power LED	Output LED	Dimension Drawings	Wiring Diagrams	Spec List
Bi15U-CK40-ADZ30X2-B1131 W/BS2.1 4280090	Uprox	•	15	2-wire AC/DC	20-250 VAC/10-300 VDC	10	≤400/300	-30 to +85	IP68	PBT	PBT	GN	YE	A	1	A5
Bi15U-CK40-ADZ30X2-B3131 W/B 2.1 4280091	Uprox	•	15	2-wire AC/DC	20-250 VAC/10-300 VDC	10	≤400/300	-30 to +85	IP68	PBT	PBT	GN	YE	B	2	A5
Bi15-CK40-AZ3X2-B1131 W/BS2.1 1335091		•	15	2-wire AC/DC	20-250 VAC/10-300 VDC	20	≤400/300	-25 to +70	IP67	PBT	PBT	GN	YE	A	1	A5
Bi15-CK40-AZ3X2-B3131 W/BS2.1 1335095		•	15	2-wire AC	20-250 VAC/10-300 VDC	20	≤400/300	-25 to +70	IP67	PBT	PBT	GN	YE	B	2	A6
Ni20-CK40-AZ3X2-B1131 W/BS2.1 1335291			20	2-wire AC	20-250 VAC/10-300 VDC	20	≤400/300	-25 to +70	IP67	PBT	PBT	GN	YE	A	1	A6
Ni20-CK40-AZ3X2-B3131 W/BS2.1 1335290			20	2-Wire AC	20-250 VAC/10-300 VDC	20	≤400/300	-25 to +70	IP67	PBT	PBT	GN	YE	B	2	A6
Ni25U-CK40-ADZ30X2-B1131 W/BS2.1 4280290	Uprox		25	2-wire AC/DC	20-250 VAC/10-300 VDC	10	≤400/300	-30 to +85	IP67	PBT	PBT	GN	YE	A	1	A5
Ni25U-CK40-ADZ30X2-B3131 W/BS2.1 4280291	Uprox		25	2-wire AC/DC	20-250 VAC/10-300 VDC	10	≤400/300	-30 to +85	IP67	PBT	PBT	GN	YE	B	2	A5
Ni35U-CK40-ADZ30X2-B1131 4280410	Uprox		35	2-wire AC/DC	20-250 VAC/10-300 VDC	10	≤400/300	-30 to +85	IP68	PBT	PBT	GN	YE	A	1	A5

We reserve the right to make technical alterations without prior notice.

Rectangular Inductive Sensors



# Rectangular Inductive Sensors | CP40

## Rotatable Sensing Head with 2 and 3-wire DC Outputs and Terminal Chamber

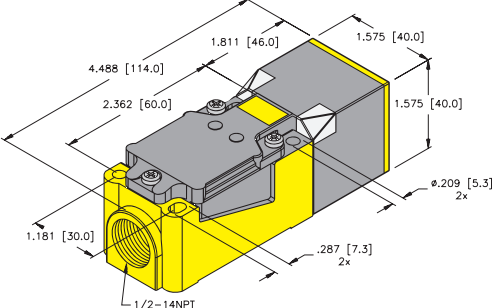
Housing Style	Dimension Drawings
	<p data-bbox="836 336 853 357">A</p>  <p data-bbox="959 648 1404 670">CP40 - Embeddable/Nonembeddable, Terminal Chamber</p>

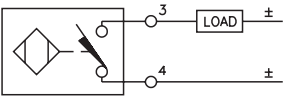
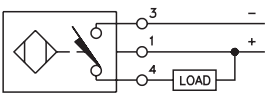
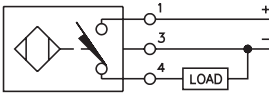
Wiring Diagrams/Mating Cordsets		
<p data-bbox="131 735 147 756">1</p> 	<p data-bbox="604 735 621 756">2</p> 	<p data-bbox="1078 735 1095 756">3</p> 

A2	2-wire DC - (AD, RD, AG)	
<p data-bbox="430 978 567 1000">Ripple: <math>\leq 10\%</math></p> <p data-bbox="241 1009 668 1030">Differential Travel (Hysteresis): 3-15% (5% typical)</p> <p data-bbox="157 1039 729 1086">Voltage Drop Across Conducting Sensor: Non-polarized (AD) <math>&lt; 5.0\text{ V}</math> Polarized (AG) <math>\leq 4.2\text{ V}</math></p> <p data-bbox="136 1095 591 1116">Trigger Current for Short Circuit Protection: <math>\geq 120\text{ mA}</math></p> <p data-bbox="295 1125 584 1146">Minimum Load Current: <math>\geq 3.0\text{ mA}</math></p>	<p data-bbox="942 978 1266 1000">Off-State (Leakage) Current: <math>\leq 0.8\text{ mA}</math></p> <p data-bbox="1031 1009 1323 1030">Power-On Effect: Per IEC 947-5-2</p> <p data-bbox="997 1039 1337 1060">Transient Protection: Per EN 60947-5-2</p> <p data-bbox="1110 1069 1290 1090">Shock: 30 g, 11 ms</p> <p data-bbox="1085 1099 1501 1121">Vibration: 55 Hz, 1 mm Amplitude in all 3 Planes</p> <p data-bbox="1051 1129 1468 1151">Repeatability: <math>\leq 2\%</math> of Rated Operating Distance</p>	

A4	3 and 4-wire DC - (AN, RN, AP, RP, VN, VP)	
<p data-bbox="430 1203 567 1224">Ripple: <math>\leq 10\%</math></p> <p data-bbox="241 1233 668 1254">Differential Travel (Hysteresis): 3-15% (5% typical)</p> <p data-bbox="157 1263 567 1284">Voltage Drop Across Conducting Sensor: <math>\leq 1.8\text{ V}</math></p> <p data-bbox="136 1293 796 1371">Trigger Current for Short Circuit Protection: <math>\geq 220\text{ mA}</math> on 200 mA Load Current <math>\geq 170\text{ mA}</math> on 150 mA Load Current <math>\geq 120\text{ mA}</math> on 100 mA Load Current</p> <p data-bbox="262 1379 584 1401">Off-State (Leakage) Current: <math>\leq 0.1\text{ mA}</math></p> <p data-bbox="346 1410 813 1431">No-Load Current: <math>\leq 15\text{ mA}</math> (Ferrite, Uprox, Rectangular)</p> <p data-bbox="346 1440 729 1461">No-Load Current: <math>\leq 20\text{ mA}</math> (Uprox+, Uprox 3)</p> <p data-bbox="241 1470 567 1491">Time Delay Before Availability: <math>\leq 8\text{ ms}</math></p>	<p data-bbox="1031 1203 1317 1224">Power-On Effect: Per IEC 947-5-2</p> <p data-bbox="947 1233 1300 1254">Reverse Polarity Protection: Incorporated</p> <p data-bbox="981 1263 1300 1284">Wire-Break Protection: Incorporated</p> <p data-bbox="997 1293 1333 1315">Transient Protection: Per EN 60947-5-2</p> <p data-bbox="1014 1323 1165 1345">Temperature Drift: <math>\leq \pm 10\%</math></p> <p data-bbox="1110 1353 1290 1375">Shock: 30 g, 11 ms</p> <p data-bbox="1085 1384 1491 1405">Vibration: 55 Hz, 1 mm Amplitude in all 3 Planes</p> <p data-bbox="1051 1414 1458 1435">Repeatability: <math>\leq 2\%</math> of Rated Operating Distance</p>	

We reserve the right to make technical alterations without prior notice.

## Rectangular Inductive Sensors | CP40

### Rotatable Sensing Head with 2 and 3-wire DC Outputs and Terminal Chamber

Part Number/ ID Number	Features	Embeddable	Sensing Range (mm)	Output	Voltage	Switching Freq. (Hz)	Operating Current (mA)	Operating Temp. (°C)	Protection	Housing	Front Cap/Face	Power LED	Output LED	Dimension Drawings	Wiring Diagrams	Spec List
Bi15U-CP40-AP6X2 1623502	Uprox	•	15	3-wire DC PNP	10-30 VDC	250	≤200	-30 to +85	IP68	PBT	PBT	GN	YE	A	3	A4
Bi15-CP40-AN6X2 1623000		•	15	3-wire DC NPN	10-30 VDC	150	≤200	-25 to +70	IP67	PBT	PBT	GN	YE	A	2	A4
Bi15-CP40-AN6X2/S10-S97 1623001	Low Temp. -40 °C	•	15	3-wire DC NPN	10-30 VDC	250	≤200	-40 to +70	IP67	PBT	PBT	GN	YE	A	2	A4
Bi15-CP40-AP6X2/S10 16030		•	15	3-Wire DC PNP	10-30 VDC	150	≤200	-25 to +70	IP67	PBT	PBT	GN	YE	A	3	A4
Bi15-CP40-AD4X/S10 44770		•	15	2-wire DC	10-65 VDC	150	≤100	-25 to +70	IP67	PBT	PBT	N/A	YE	A	1	A2
Bi20U-CP40-AP6X2/S10 1625826	Uprox+	•	20	3-wire DC PNP	10-30 VDC	250	≤200	-25 to +70	IP68	PBT	PBT	GN	YE	A	3	A4
Bi30U-CP40-AP6X2/S10 1625825	Uprox+	•	30	3-wire DC PNP	10-30 VDC	250	≤200	-10 to +60	IP68	PBT	PBT	GN	YE	A	3	A4
Ni20-CP40-AP6X2/S10 16031			20	3-wire DC PNP	10-30 VDC	150	≤200	-25 to +70	IP67	PBT	PBT	GN	YE	A	3	A4
Ni20-CP40-AD4X/S10 44771			20	2-wire DC	10-65 VDC	150	≤100	-25 to +70	IP67	PBT	PBT	N/A	YE	A	1	A2
Ni25U-CP40-AP6X2/S10 1623701	Uprox		25	3-wire DC PNP	10-30 VDC	250	≤200	-30 to +85	IP67	PBT	PBT	GN	YE	A	3	A4
Ni40U-CP40-AP6X2/S10 1623602	Uprox		40	3-wire DC PNP	10-30 VDC	250	≤200	-30 to +85	IP68	PBT	PBT	GN	YE	A	3	A4
Ni50U-CP40-AN6X2/S10 1625824	Uprox+		50	3-wire DC NPN	10-30 VDC	250	≤200	-25 to +70	IP68	PBT	PBT	GN	YE	A	2	A4
Ni50U-CP40-AP6X2/S10 1625842	Uprox+		50	3-wire DC PNP	10-30 VDC	250	≤200	-30 to +85	IP68	PBT	PBT	GN	YE	A	3	A4

We reserve the right to make technical alterations without prior notice.

Rectangular Inductive Sensors

# Rectangular Inductive Sensors | CP40

## Rotatable Sensing Head with Complementary Outputs and Terminal Chamber

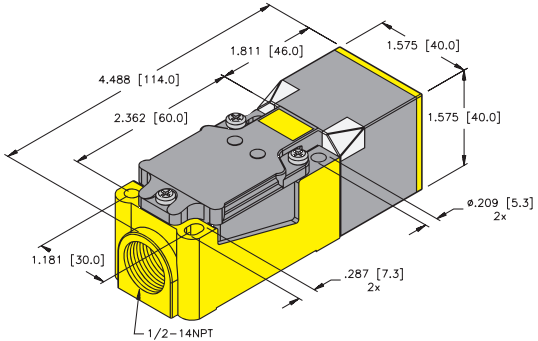
Housing Style	Dimension Drawings
	<p>A</p>  <p>CP40 - Embeddable/Nonembeddable, Terminal Chamber</p>

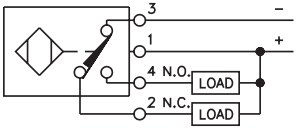
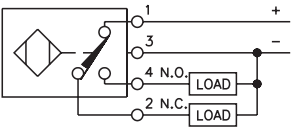
Wiring Diagrams/Mating Cordsets	
<p>1</p> 	<p>2</p> 

A4 3 and 4-wire DC - (AN, RN, AP, RP, VN, VP)	
<p>Ripple: <math>\leq 10\%</math></p> <p>Differential Travel (Hysteresis): 3-15% (5% typical)</p> <p>Voltage Drop Across Conducting Sensor: <math>\leq 1.8\text{ V}</math></p> <p>Trigger Current for Short Circuit Protection:  <math>\geq 220\text{ mA}</math> on 200 mA Load Current  <math>\geq 170\text{ mA}</math> on 150 mA Load Current  <math>\geq 120\text{ mA}</math> on 100 mA Load Current</p> <p>Off-State (Leakage) Current: <math>\leq 0.1\text{ mA}</math></p> <p>No-Load Current: <math>\leq 15\text{ mA}</math> (Ferrite, Uprox, Rectangular)  <math>\leq 20\text{ mA}</math> (Uprox+, Uprox 3)</p> <p>Time Delay Before Availability: <math>\leq 8\text{ ms}</math></p>	<p>Power-On Effect: Per IEC 947-5-2</p> <p>Reverse Polarity Protection: Incorporated</p> <p>Wire-Break Protection: Incorporated</p> <p>Transient Protection: Per EN 60947-5-2</p> <p>Temperature Drift: <math>\leq \pm 10\%</math></p> <p>Shock: 30 g, 11 ms</p> <p>Vibration: 55 Hz, 1 mm Amplitude in all 3 Planes</p> <p>Repeatability: <math>\leq 2\%</math> of Rated Operating Distance</p>

We reserve the right to make technical alterations without prior notice.

# Rectangular Inductive Sensors | CP40

## Rotatable Sensing Head with Complementary Outputs and Terminal Chamber

Part Number/ ID Number	Features	Embeddable	Sensing Range (mm)	Output	Voltage	Switching Freq. (Hz)	Operating Current (mA)	Operating Temp. (°C)	Protection	Housing	Front Cap/Face	Power LED	Output LED	Dimension Drawings	Wiring Diagrams	Spec List
Bi15U-CP40-VN4X2/S10 1540511	Uprox	•	15	4-wire DC NPN	10-65 VDC	250	≤200	-30 to +85	IP68	PBT	PBT	GN	YE	A	1	A4
Bi15U-CP40-VP4X2/S10 1540501	Uprox	•	15	4-wire DC PNP	10-65 VDC	250	≤200	-30 to +85	IP67	PBT	PBT	GN	YE	A	2	A4
Bi15-CP40-VN4X2/S100 15250	Comp. Outputs	•	15	4-wire DC NPN	10-65 VDC	150	≤200	-25 to +70	IP67	PBT	PBT	GN	YE	A	1	A4
Bi15-CP40-VN4X2/S100-S10 15144	High Temp. 100 °C	•	15	4-wire DC NPN	10-65 VDC	150	≤200	-25 to +100	IP67	PBT	PBT	GN	YE	A	1	A4
Bi15-CP40-VP4X2/S10 15010	Comp. Outputs	•	15	4-wire DC PNP	10-65 VDC	150	≤200	-25 to +70	IP67	PBT	PBT	GN	YE	A	2	A4
Bi15-CP40-VP4X2/S100-S10 15019	High Temp. 100 °C	•	15	4-wire DC PNP	10-65 VDC	150	≤200	-25 to +100	IP67	PBT	PBT	GN	YE	A	2	A4
Bi20-CP40-VN4X2/S10 1579221	Ext. Range	•	20	4-wire DC NPN	10-65 VDC	100	≤200	-25 to +70	IP67	PBT	PBT	GN	YE	A	1	A4
Bi20-CP40-VP4X2/S10 15012	Ext. Range	•	20	4-wire DC PNP	10-65 VDC	100	≤200	-25 to +70	IP67	PBT	PBT	GN	YE	A	2	A4
Ni20-CP40-VN4X2/S10 15251	Comp. Outputs		20	4-wire DC NPN	10-65 VDC	150	≤200	-25 to +70	IP67	PBT	PBT	GN	YE	A	1	A4
Ni20-CP40-VP4X2/S10 15011	Comp. Outputs		20	4-wire DC PNP	10-65 VDC	150	≤200	-25 to +70	IP67	PBT	PBT	GN	YE	A	2	A4
Ni20-CP40-VP4X2/S100-S10 15020	High Temp. 100 °C		20	4-wire DC PNP	10-65 VDC	150	≤200	-25 to +100	IP67	PBT	PBT	GN	YE	A	2	A4
Ni35-CP40-VN4X2/S10 15254	Comp. Outputs		35	4-wire DC NPN	10-65 VDC	150	≤200	-25 to +70	IP67	PBT	PBT	GN	YE	A	1	A4
Ni35-CP40-VP4X2/S10 15014	Comp. Outputs		35	4-wire DC PNP	10-65 VDC	150	≤200	-25 to +70	IP67	PBT	PBT	GN	YE	A	2	A4
Ni40U-CP40-VN4X2/S10 1540611	Uprox, Ext. Range		40	4-wire DC NPN	10-65 VDC	250	≤200	-30 to +85	IP68	PBT	PBT	GN	YE	A	1	A4
Ni40U-CP40-VP4X2/S10 1540601	Uprox, Ext. Range		40	4-wire DC PNP	10-65 VDC	250	≤200	-30 to +85	IP68	PBT	PBT	GN	YE	A	2	A4
Ni50U-CP40-VN4X2/S10 1625807	Uprox+		50	4-wire DC NPN	10-65 VDC	250	≤200	-30 to +85	IP68	PBT	PBT	GN	YE	A	1	A4
Ni50U-CP40-VP4X2 1538303	Uprox+		50	4-wire DC PNP	10-65 VDC	250	≤200	-30 to +85	IP68	PBT	PBT	GN	YE	A	2	A4

We reserve the right to make technical alterations without prior notice.

Rectangular Inductive Sensors



# Rectangular Inductive Sensors | CP40

## Rotatable Sensing Head with AC/DC Outputs and Terminal Chamber

Part Number/ ID Number	Features	Embeddable	Sensing Range (mm)	Output	Voltage	Switching Freq. (Hz)	Operating Current (mA)	Operating Temp. (°C)	Protection	Housing	Front Cap/Face	Power LED	Output LED	Dimension Drawings	Wiring Diagrams	Spec List
Bi15U-CP40-FDZ30X2 4280601	Uprox	•	15	2-wire AC/DC	20-250 VAC/10-300 VDC	10	≤400/300	-30 to +85	IP67	PBT	PBT	GN	YE	A	1	A5
Bi15-CP40-FDZ30X2/S10 42241	Prog. Outputs	•	15	2-wire AC/DC	20-250 VAC/10-300 VDC	60	≤400/300	-25 to +70	IP67	PBT	PBT	GN	YE	A	1	A5
Bi15-CP40-FDZ30X2/S10-S97 42266	Low Temp. -40 °C	•	15	2-wire AC/DC	20-250 VAC/10-300 VDC	60	≤400/300	-40 to +70	IP67	PBT	PBT	GN	YE	A	1	A5
Bi15-CP40-FZ3X2/S109-S10 13737	Time Delay	•	15	2-wire AC	20-250 VAC/10-300 VDC	20	≤400/300	-25 to +70	IP67	PBT	PBT	GN	YE	B	1	A6
Bi15-CP40-FZ3X2/S110-S10 13735	Time Delay	•	15	2-wire AC	20-250 VAC/10-300 VDC	20	≤400/300	-25 to +70	IP67	PBT	PBT	GN	YE	B	1	A6
Bi15-CP40-FZ3X2/S10 13410	Prog. Outputs	•	15	2-wire AC	20-250 VAC/10-300 VDC	20	≤400/300	-25 to +70	IP67	PBT	PBT	GN	YE	A	1	A6
Bi15-CP40-FZ3X2/S10-S97 1341010	Low Temp. -40 °C	•	15	2-wire AC	20-250 VAC/10-300 VDC	20	≤400/300	-40 to +70	IP67	PBT	PBT	GN	YE	A	1	A6
Bi15-CP40-FZ3X2/S100-S10 13776	High Temp. 100 °C	•	15	2-wire AC	20-250 VAC/10-300 VDC	20	≤400/300	-25 to +100	IP67	PBT	PBT	GN	YE	A	1	A6
Ni20-CP40-FDZ30X2/S10 42242	Prog. Outputs		20	2-wire AC/DC	20-250 VAC/10-300 VDC	60	≤400/300	-25 to +70	IP67	PBT	PBT	GN	YE	A	1	A5
Ni20-CP40-FZ3X2/S100 13411	Prog. Outputs		20	2-wire AC	20-250 VAC/10-300 VDC	20	≤400/300	-25 to +70	IP67	PBT	PBT	GN	YE	A	1	A6
Ni20-CP40-FZ3X2/S100-S10 13775	High Temp. 100 °C		20	2-wire AC	20-250 VAC/10-300 VDC	20	≤400/300	-25 to +100	IP67	PBT	PBT	GN	YE	A	1	A6
Ni20-CP40-FZ3X2/S110-S10 13746	Time Delay		20	2-wire AC	20-250 VAC/10-300 VDC	20	≤400/300	-25 to +70	IP67	PBT	PBT	GN	YE	B	1	A6
Ni30-CP40-FZ3X2/S109-S10 13747	Time Delay		30	2-wire AC	20-250 VAC/10-300 VDC	20	≤400/300	-25 to +70	IP67	PBT	PBT	GN	YE	B	1	A6
Ni30-CP40-FZ3X2/S110-S10 13744	Time Delay		30	2-wire AC	20-250 VAC/10-300 VDC	20	≤400/300	-25 to +70	IP67	PBT	PBT	GN	YE	B	1	A6
Ni35-CP40-FDZ30X2/S10 42245	Prog. Outputs		35	2-wire AC/DC	20-250 VAC/10-300 VDC	60	≤400/300	-25 to +70	IP67	PBT	PBT	GN	YE	A	1	A5
Ni35-CP40-FZ3X2/S10 13413	Prog. Outputs		35	2-wire AC	20-250 VAC/10-300 VDC	20	≤400/300	-25 to +70	IP67	PBT	PBT	GN	YE	A	1	A6
Ni40U-CP40-FDZ30X2/S10 4280801	Uprox		40	2-wire AC/DC	20-250 VAC/10-300 VDC	10	≤400/300	-30 to +85	IP68	PBT	PBT	GN	YE	A	1	A5
Ni40-CP40-FZ3X2/S100-S10 1374802	High Temp. 100 °C		40	2-wire AC	20-250 VAC/10-300 VDC	20	≤400/300	-25 to +100	IP67	PBT	PBT	GN	YE	A	1	A6

We reserve the right to make technical alterations without prior notice.

Rectangular Inductive Sensors

# Rectangular Inductive Sensors | CP80

## Top Sensing with 3 and 4-Wire DC Outputs and Terminal Chamber

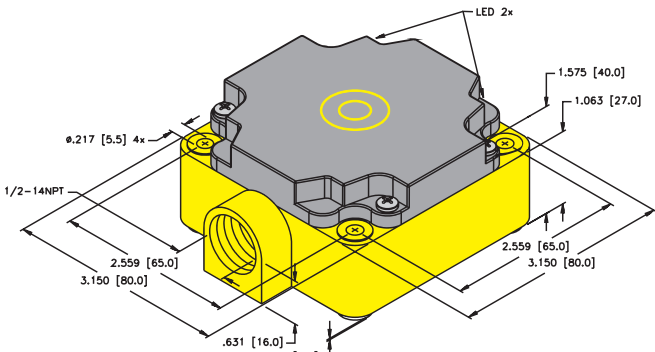
Housing Style	Dimension Drawings
	 <p>CP80 - Embeddable/Nonembeddable, Terminal Chamber</p>

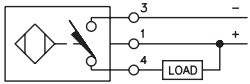
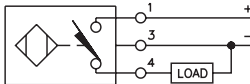
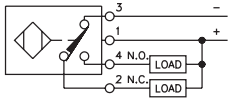
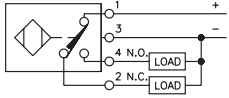
Wiring Diagrams/Mating Cordsets	
<p>1</p> 	<p>2</p> 
<p>3</p> 	<p>4</p> 

A4 3 and 4-wire DC - (AN, RN, AP, RP, VN, VP)	
<p>Ripple: <math>\leq 10\%</math></p> <p>Differential Travel (Hysteresis): 3-15% (5% typical)</p> <p>Voltage Drop Across Conducting Sensor: <math>\leq 1.8\text{ V}</math></p> <p>Trigger Current for Short Circuit Protection:  <math>\geq 220\text{ mA}</math> on 200 mA Load Current  <math>\geq 170\text{ mA}</math> on 150 mA Load Current  <math>\geq 120\text{ mA}</math> on 100 mA Load Current</p> <p>Off-State (Leakage) Current: <math>\leq 0.1\text{ mA}</math></p> <p>No-Load Current: <math>\leq 15\text{ mA}</math> (Ferrite, Uprox, Rectangular)  <math>\leq 20\text{ mA}</math> (Uprox+, Uprox 3)</p> <p>Time Delay Before Availability: <math>\leq 8\text{ ms}</math></p>	<p>Power-On Effect: Per IEC 947-5-2</p> <p>Reverse Polarity Protection: Incorporated</p> <p>Wire-Break Protection: Incorporated</p> <p>Transient Protection: Per EN 60947-5-2</p> <p>Temperature Drift: <math>\leq \pm 10\%</math></p> <p>Shock: 30 g, 11 ms</p> <p>Vibration: 55 Hz, 1 mm Amplitude in all 3 Planes</p> <p>Repeatability: <math>\leq 2\%</math> of Rated Operating Distance</p>

We reserve the right to make technical alterations without prior notice.

# Rectangular Inductive Sensors | CP80

## Top Sensing with 3 and 4-Wire DC Outputs and Terminal Chamber

Part Number/ ID Number	Features	Embeddable	Sensing Range (mm)	Output	Voltage	Switching Freq. (Hz)	Operating Current (mA)	Operating Temp. (°C)	Protection	Housing	Front Cap/Face	Power LED	Output LED	Dimension Drawings	Wiring Diagrams	Spec List
Bi40-CP80-VN4X2/S10 1579800	Comp. Outputs	•	40	4-wire DC NPN	10-65 VDC	100	≤200	-25 to +70	IP67	PBT	PBT	GN	YE	A	3	A4
Bi40-CP80-VP4X2/S10 15698	Comp. Outputs	•	40	4-wire DC PNP	10-65 VDC	100	≤200	-25 to +70	IP67	PBT	PBT	GN	YE	A	4	A4
Ni40-CP80-VP4X2/S10 15015	Comp. Outputs		40	4-wire DC PNP	10-65 VDC	100	≤200	-25 to +70	IP67	PBT	PBT	GN	YE	A	4	A4
Ni50-CP80-VN4X2/S10 15256	Comp. Outputs		50	4-wire DC NPN	10-65 VDC	100	≤200	-25 to +70	IP67	PBT	PBT	GN	YE	A	3	A4
Ni50-CP80-VP4X2/S10 15016	Comp. Outputs		50	4-wire DC PNP	10-65 VDC	100	≤200	-25 to +70	IP67	PBT	PBT	GN	YE	A	4	A4
Ni75U-CP80-AN6X2/S10 1623811	Uprox		75	3-wire DC NPN	10-30 VDC	250	≤200	-30 to +85	IP67	PBT	PBT	GN	YE	A	1	A4
Ni75U-CP80-AP6X2/S10 1623801	Uprox		75	3-wire DC PNP	10-30 VDC	250	≤200	-30 to +85	IP67	PBT	PBT	GN	YE	A	2	A4
Ni75U-CP80-VN4X2/S10 1540811	Uprox		75	4-wire DC NPN	10-65 VDC	250	≤200	-30 to +85	IP67	PBT	PBT	GN	YE	A	3	A4
Ni75U-CP80-VP4X2/S10 1540801	Uprox		75	4-wire DC PNP	10-65 VDC	250	≤200	-30 to +85	IP67	PBT	PBT	GN	YE	A	4	A4

We reserve the right to make technical alterations without prior notice.

Rectangular Inductive Sensors



# Rectangular Inductive Sensors | CP80

## Top Sensing with AC/DC Outputs and Terminal Chamber

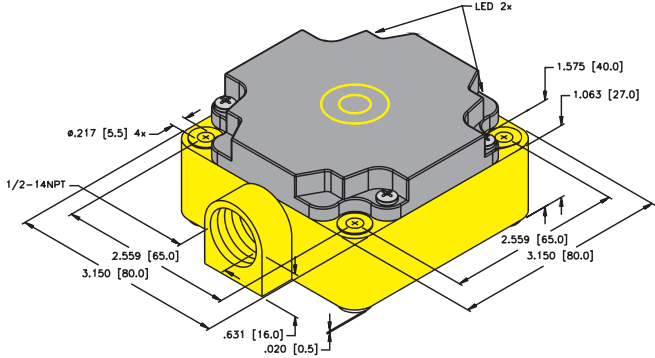
Housing Style	Dimension Drawings
	 <p>CP80 - Embeddable/Nonembeddable, Terminal Chamber</p>

### Wiring Diagrams/Mating Cordsets

1

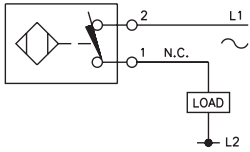

—OR—

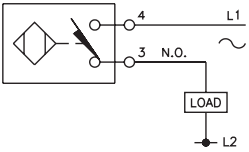

A5	2-wire AC/DC w/ Short-Circuit Protection - (ADZ, RDZ, FDZ, VDZ)	
<p>Line Frequency: <math>\geq 50 \dots \leq 60</math> Hz</p> <p>Differential Travel (Hysteresis): 3-15% (5% typical)</p> <p>Voltage Drop Across Conducting Sensor: <math>\leq 6.0</math> V</p> <p>Trigger Current for Short Circuit Protection: AC: <math>\geq 440</math> mA; DC: <math>\geq 330</math> mA AC: <math>\geq 120</math> mA; DC: <math>\geq 120</math> mA</p> <p>Continuous Load Current: AC: <math>\leq 400</math> mA; DC: <math>\leq 300</math> mA AC: <math>\leq 100</math> mA; DC: <math>\leq 100</math> mA</p> <p>Off-State (leakage) Current: <math>\leq 1.7</math> mA (AC) <math>\leq 1.5</math> mA (DC)</p>	<p>Minimum Load Current: <math>\geq 3.0</math> mA</p> <p>Inrush Current: <math>\leq 3.0</math> A (<math>\leq 20</math> ms, max 5 Hz)</p> <p>Power-On Effect: Per IEC 947-5-2</p> <p>Transient Protection: Per EN 60947-5-2</p> <p>Shock: 30 g, 11 ms</p> <p>Vibration: 55 Hz, 1 mm Amplitude, in all 3 Planes</p> <p>Repeatability: <math>\leq 2\%</math> of Rated Operating Distance</p>	
A6	2-wire AC/DC w/o Short-Circuit Protection - (AZ, RZ, FZ)	
<p>Line Frequency: <math>\geq 50 \dots \leq 60</math> Hz</p> <p>Differential Travel (Hysteresis): 3-15% (5% typical)</p> <p>Voltage Drop Across Conducting Sensor: <math>\leq 6.0</math> V</p> <p>Continuous Load Current: AC: <math>\leq 400</math> mA; DC: <math>\leq 300</math> mA AC: <math>\leq 100</math> mA; DC: <math>\leq 100</math> mA</p> <p>Off-State (Leakage) Current: <math>\leq 1.7</math> mA</p> <p>Minimum Load Current: <math>\geq 3.0</math> mA</p>	<p>Inrush Current: <math>\leq 8</math> A (<math>\leq 10</math>ms max. 5 Hz) <math>\leq 1</math> A (<math>\leq 10</math> ms max. 5 Hz) 12 mm <math>\leq 0.2</math> A (<math>\leq 10</math> ms max. 0.2 Hz) 8 mm</p> <p>Power-On Effect: Per IEC 947-5-2</p> <p>Transient Protection: Per EN 60947-5-2</p> <p>Shock: 30 g, 11 ms</p> <p>Vibration: 55 Hz, 1 mm Amplitude, in all 3 Planes</p> <p>Repeatability: <math>\leq 2\%</math> of Rated Operating Distance</p>	

We reserve the right to make technical alterations without prior notice.

## Rectangular Inductive Sensors | CP80

### Top Sensing with AC/DC Outputs and Terminal Chamber

Part Number/ ID Number	Features	Embeddable	Sensing Range (mm)	Output	Voltage	Switching Freq. (Hz)	Operating Current (mA)	Operating Temp. (°C)	Protection	Housing	Front Cap/Face	Power LED	Output LED	Dimension Drawings	Wiring Diagrams	Spec List
<b>Bi40-CP80-FDZ30X2/S10</b> 4230901	Prog. Outputs	•	40	2-wire AC/DC	20-250 VAC/10-300 VDC	20	≤400/300	-25 to +70	IP67	PBT	PBT	GN	YE	A	1	A5
<b>Bi40-CP80-FZ3X2/S10</b> 1340401	Prog. Outputs	•	40	2-wire AC	20-250 VAC/10-300 VDC	20	≤400/300	-25 to +70	IP67	PBT	PBT	GN	YE	A	1	A6
<b>Ni40-CP80-FZ3X2/S100</b> 13415	Prog. Outputs		40	2-wire AC	20-250 VAC/10-300 VDC	20	≤400/300	-25 to +70	IP67	PBT	PBT	GN	YE	A	1	A6
<b>Ni40-CP80-FZ3X2/S100-S10</b> 13453	High Temp. 100 °C		40	2-wire AC	20-250 VAC/10-300 VDC	20	≤400/300	-25 to +100	IP67	PBT	PBT	GN	YE	A	1	A6
<b>Ni50-CP80-FZ3X2/S10</b> 13410	Prog. Outputs		50	2-wire AC	20-250 VAC/10-300 VDC	20	≤400/300	-25 to +70	IP67	PBT	PBT	GN	YE	A	1	A6
<b>Ni50-CP80-FDZ30X2/S100</b> 42321	Prog. Outputs		50	2-wire AC/DC	20-250 VAC/10-300 VDC	20	≤400/300	-25 to +70	IP67	PBT	PBT	GN	YE	A	1	A5
<b>Ni50-CP80-FDZ30X2/S100-S10</b> 42290	High Temp. 100 °C		50	2-wire AC/DC	20-250 VAC/10-300 VDC	20	≤400/300	-25 to +100	IP67	PBT	PBT	GN	YE	A	1	A5
<b>Ni75U-CP80-FDZ30X2/S10</b> 4280901	Uprox		75	2-wire AC/DC	20-250 VAC/10-300 VDC	10	≤400/300	-30 to +85	IP67	PBT	PBT	GN	YE	A	1	A5

We reserve the right to make technical alterations without prior notice.

Rectangular Inductive Sensors

# Rectangular Inductive Sensors | Q80

## Top Sensing with 3 and 4-Wire DC or AC/DC Outputs

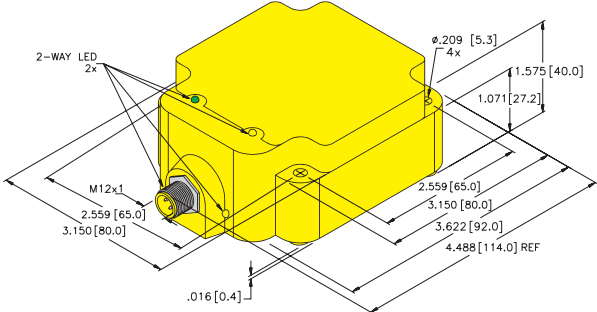
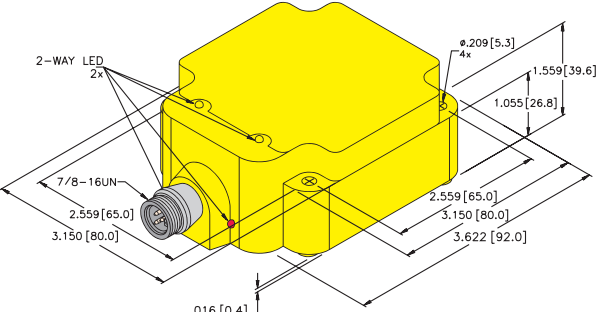
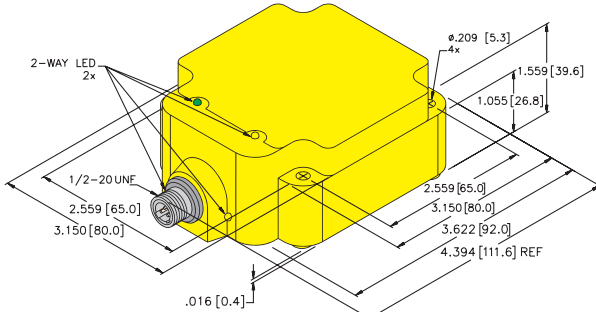
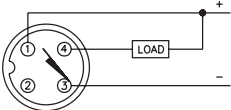
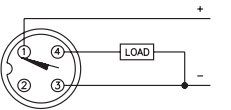
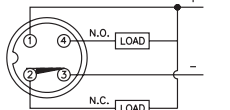
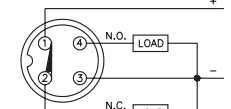
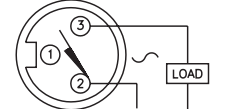
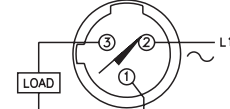
Housing Style	Dimension Drawings	
	<p><b>A</b></p>  <p>Q80 - Embeddable/Nonembeddable, Eurofast Connector</p>	
<p><b>B</b></p>  <p>Q80 - Embeddable, Minifast Connector</p>	<p><b>C</b></p>  <p>Q80 - Embeddable, Microfast Connector</p>	
Wiring Diagrams/Mating Cordsets		
<p><b>1</b></p>  <p>Mating Cordset: RK 4T-*</p>	<p><b>2</b></p>  <p>Mating Cordset: RK 4T-*</p>	<p><b>3</b></p>  <p>Mating Cordset: RK 4.4T-*</p>
<p><b>4</b></p>  <p>Mating Cordset: RK 4.4T-*</p>	<p><b>5</b></p>  <p>Mating Cordset: RKM 30-*M</p>	<p><b>6</b></p>  <p>Mating Cordset: KB 3T-*</p>
A4 3 and 4-wire DC - (AN, RN, AP, RP, VN, VP)		
<p>Ripple: ≤10%</p> <p>Differential Travel (Hysteresis): 3-15% (5% typical)</p> <p>Voltage Drop Across Conducting Sensor: ≤1.8 V</p> <p>Trigger Current for Short Circuit Protection: ≥220 mA on 200 mA Load Current ≥170 mA on 150 mA Load Current ≥120 mA on 100 mA Load Current</p> <p>Off-State (Leakage) Current: ≤0.1 mA</p> <p>No-Load Current: ≤15 mA (Ferrite, Uprox, Rectangular) ≤20 mA (Uprox+, Uprox 3)</p> <p>Time Delay Before Availability: ≤8 ms</p>	<p>Power-On Effect: Per IEC 947-5-2</p> <p>Reverse Polarity Protection: Incorporated</p> <p>Wire-Break Protection: Incorporated</p> <p>Transient Protection: Per EN 60947-5-2</p> <p>Temperature Drift: ≤±10%</p> <p>Shock: 30 g, 11 ms</p> <p>Vibration: 55 Hz, 1 mm Amplitude in all 3 Planes</p> <p>Repeatability: ≤2% of Rated Operating Distance</p>	
A5 2-wire AC/DC w/ Short-Circuit Protection - (ADZ, RDZ, FDZ, VDZ)		
<p>Line Frequency: ≥50... ≤60 Hz</p> <p>Differential Travel (Hysteresis): 3-15% (5% typical)</p> <p>Voltage Drop Across Conducting Sensor: ≤6.0 V</p> <p>Trigger Current for Short Circuit Protection: AC: ≥440 mA; DC: ≥330 mA AC: ≥120 mA; DC: ≥120 mA</p> <p>Continuous Load Current: AC: ≤400 mA; DC: ≤300 mA AC: ≤100 mA; DC: ≤100 mA</p> <p>Off-State (Leakage) Current: ≤1.7 mA (AC) ≤1.5 mA (DC)</p>	<p>Minimum Load Current: ≥3.0 mA</p> <p>Inrush Current: ≤3.0 A (≤20 ms, max 5 Hz)</p> <p>Power-On Effect: Per IEC 947-5-2</p> <p>Transient Protection: Per EN 60947-5-2</p> <p>Shock: 30 g, 11 ms</p> <p>Vibration: 55 Hz, 1 mm Amplitude, in all 3 Planes</p> <p>Repeatability: ≤2% of Rated Operating Distance</p>	

We reserve the right to make technical alterations without prior notice.

## Rectangular Inductive Sensors | Q80

### Top Sensing with 3 and 4-Wire DC or AC/DC Outputs

Part Number/ ID Number	Features	Embeddable	Sensing Range (mm)	Output	Voltage	Switching Freq. (Hz)	Operating Current (mA)	Operating Temp. (°C)	Protection	Housing	Front Cap/Face	Power LED	Output LED	Dimension Drawings	Wiring Diagrams	Spec List
Bi50U-Q80-AP6X2-H1141 1608940	Uprox+	•	50	3-wire DC PNP	10-30 VDC	250	≤200	-25 to +70	IP68	PBT	PBT	GN	YE	A	2	A4
Bi50U-Q80-VN4X2-H1141 1562001	Uprox+, Comp. Outputs	•	50	4-wire DC NPN	10-65 VDC	250	≤200	-25 to +70	IP68	PBT	PBT	GN	YE	A	3	A4
Bi50U-Q80-VP4X2-H1141 15620	Uprox+, Comp. Outputs	•	50	4-wire DC PNP	10-65 VDC	250	≤200	-25 to +70	IP68	PBT	PBT	GN	YE	A	4	A4
Bi50-Q80-ADZ30X2-B1131 4200310		•	50	2-wire AC/DC	20-250 VAC/10-300 VDC	20	≤400/300	-25 to +70	IP67	PBT	PBT	GN	YE	B	5	A5
Bi50-Q80-ADZ30X2-B3131 4200311		•	50	2-wire AC/DC	20-250 VAC/10-300 VDC	20	≤400/300	-25 to +70	IP67	PBT	PBT	GN	YE	C	6	A5
Ni75U-Q80-AN6X2-H1141 1625856	Uprox+		75	3-wire DC NPN	10-30 VDC	250	≤200	-25 to +70	IP68	PBT	PBT	GN	YE	A	1	A4
Ni75U-Q80-AP6X2-H1141 1625855	Uprox+		75	3-wire DC PNP	10-30 VDC	250	≤200	-25 to +70	IP68	PBT	PBT	GN	YE	A	2	A4
Ni75U-Q80-VP4X2-H1141 1625857	Uprox+, Comp. Outputs		75	4-wire DC PNP	10-65 VDC	250	≤200	-25 to +70	IP68	PBT	PBT	GN	YE	A	4	A4

We reserve the right to make technical alterations without prior notice.

Rectangular Inductive Sensors

# Rectangular Inductive Sensors | K90 & K90SR

## Top Sensing with 4-Wire DC or AC/DC Outputs

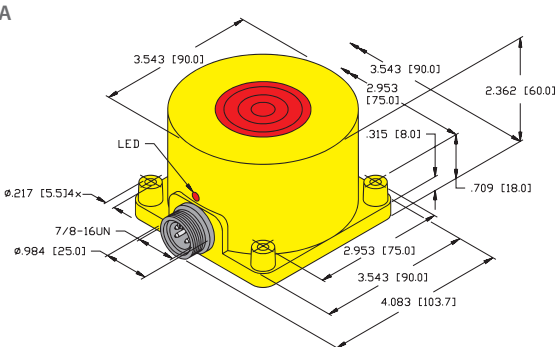
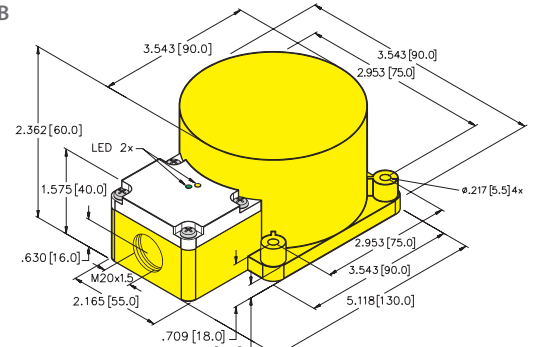
Housing Style	Dimension Drawings	
	<p><b>A</b></p>  <p style="text-align: center;">K90 - Nonembeddable, Minifast Connector</p>	<p><b>B</b></p>  <p style="text-align: center;">K90SR - Nonembeddable, Terminal Chamber</p>

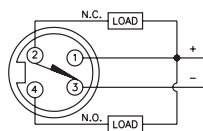
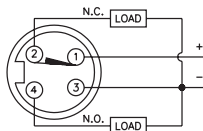
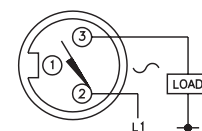
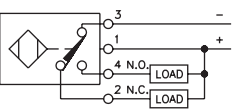
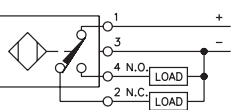
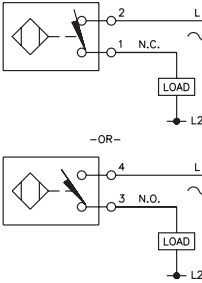
Wiring Diagrams/Mating Cordsets		
<p><b>1</b></p>  <p style="text-align: center;">Mating Cordset: RK 40-*M</p>	<p><b>2</b></p>  <p style="text-align: center;">Mating Cordset: RK 40-*M</p>	<p><b>3</b></p>  <p style="text-align: center;">Mating Cordset: RK 30-*M</p>
<p><b>4</b></p> 	<p><b>5</b></p> 	<p><b>6</b></p> 

We reserve the right to make technical alterations without prior notice.

A4 3 and 4-wire DC - (AN, RN, AP, RP, VN, VP)	
<p>Ripple: <math>\leq 10\%</math></p> <p>Differential Travel (Hysteresis): 3-15% (5% typical)</p> <p>Voltage Drop Across Conducting Sensor: <math>\leq 1.8\text{ V}</math></p> <p>Trigger Current for Short Circuit Protection: <math>\geq 220\text{ mA}</math> on 200 mA Load Current  <math>\geq 170\text{ mA}</math> on 150 mA Load Current  <math>\geq 120\text{ mA}</math> on 100 mA Load Current</p> <p>Off-State (Leakage) Current: <math>\leq 0.1\text{ mA}</math></p> <p>No-Load Current: <math>\leq 15\text{ mA}</math> (Ferrite, Uprox, Rectangular)  <math>\leq 20\text{ mA}</math> (Uprox+, Uprox 3)</p> <p>Time Delay Before Availability: <math>\leq 8\text{ ms}</math></p>	<p>Power-On Effect: Per IEC 947-5-2</p> <p>Reverse Polarity Protection: Incorporated</p> <p>Wire-Break Protection: Incorporated</p> <p>Transient Protection: Per EN 60947-5-2</p> <p>Temperature Drift: <math>\leq \pm 10\%</math></p> <p>Shock: 30 g, 11 ms</p> <p>Vibration: 55 Hz, 1 mm Amplitude in all 3 Planes</p> <p>Repeatability: <math>\leq 2\%</math> of Rated Operating Distance</p>
A6 2-wire AC/DC w/o Short-Circuit Protection - (AZ, RZ, FZ)	
<p>Line Frequency: <math>\geq 50\text{...} \leq 60\text{ Hz}</math></p> <p>Differential Travel (Hysteresis): 3-15% (5% typical)</p> <p>Voltage Drop Across Conducting Sensor: <math>\leq 6.0\text{ V}</math></p> <p>Continuous Load Current: AC: <math>\leq 400\text{ mA}</math>; DC: <math>\leq 300\text{ mA}</math>  AC: <math>\leq 100\text{ mA}</math>; DC: <math>\leq 100\text{ mA}</math></p> <p>Off-State (Leakage) Current: <math>\leq 1.7\text{ mA}</math></p> <p>Minimum Load Current: <math>\geq 3.0\text{ mA}</math></p>	<p>Inrush Current: <math>\leq 8\text{ A}</math> (<math>\leq 10\text{ ms}</math> max. 5 Hz)  <math>\leq 1\text{ A}</math> (<math>\leq 10\text{ ms}</math> max. 5 Hz) 12 mm  <math>\leq 0.2\text{ A}</math> (<math>\leq 10\text{ ms}</math> max. 0.2 Hz) 8 mm)</p> <p>Power-On Effect: Per IEC 947-5-2</p> <p>Transient Protection: Per EN 60947-5-2</p> <p>Shock: 30 g, 11 ms</p> <p>Vibration: 55 Hz, 1 mm Amplitude in all 3 Planes</p> <p>Repeatability: <math>\leq 2\%</math> of Rated Operating Distance</p>

## Rectangular Inductive Sensors | K90 & K90SR

### Top Sensing with 4-Wire DC or AC/DC Outputs

Part Number/ ID Number	Features	Embeddable	Sensing Range (mm)	Output	Voltage	Switching Freq. (Hz)	Operating Current (mA)	Operating Temp. (°C)	Protection	Housing	Front Cap/Face	Power LED	Output LED	Dimension Drawings	Wiring Diagrams	Spec List
Ni60-K90-VN4X-B2141 15203	Comp. Outputs		60	4-wire DC NPN	10-65 VDC	60	≤200	-25 to +70	IP67	PUR	PUR	N/A	YE	A	1	A4
Ni60-K90-VP4X-B2141 15103	Comp. Outputs		60	4-wire DC PNP	10-65 VDC	60	≤200	-25 to +70	IP67	PUR	PUR	N/A	YE	A	2	A4
Ni60-K90-AZ3X-B2131 13542			60	2-wire AC	20-250 VAC/10-300 VDC	20	≤500	-25 to +70	IP67	PBT	PBT	N/A	YE	A	3	A6
Ni60-K90SR-VN4X2 15740	Comp. Outputs		60	4-wire DC NPN	10-65 VDC	60	≤200	-25 to +70	IP67	PBT	PBT	GN	YE	B	4	A4
Ni60-K90SR-VP4X2 15640	Comp. Outputs		60	4-wire DC PNP	10-65 VDC	250	≤200	-30 to +85	IP68	PBT	PBT	GN	YE	B	5	A4
Ni60-K90SR-FZ3X2 13429	Prog. Outputs		60	2-wire AC	20-250 VAC/10-300 VDC	20	≤400/300	-25 to +70	IP67	PBT	PBT	GN	YE	B	6	A6
Ni100U-K90SR-VP4X2 1625834	Uprox+, Comp. Outputs		100	4-wire DC PNP	10-65 VDC	60	≤200	-25 to +70	IP67	PBT	PBT	GN	YE	B	5	A4

We reserve the right to make technical alterations without prior notice.

Rectangular Inductive Sensors

# Rectangular Inductive Sensors | Namur



## Dimension Drawings

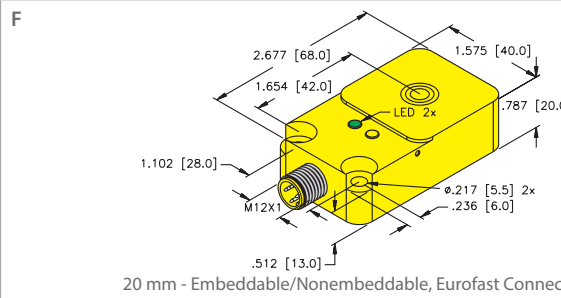
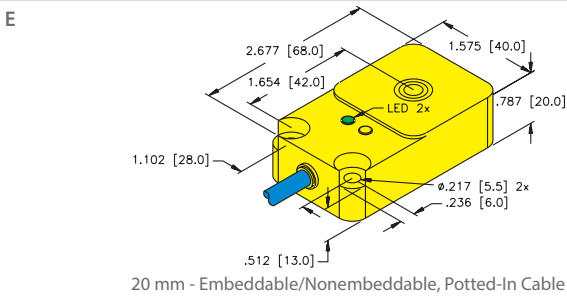
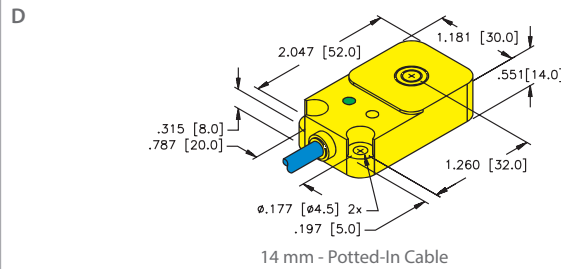
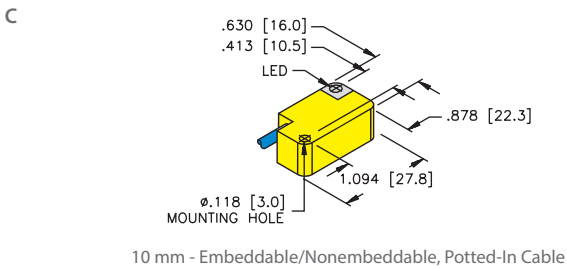
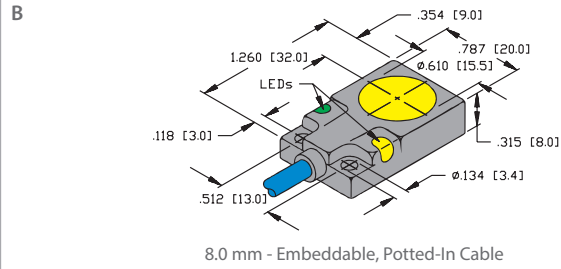
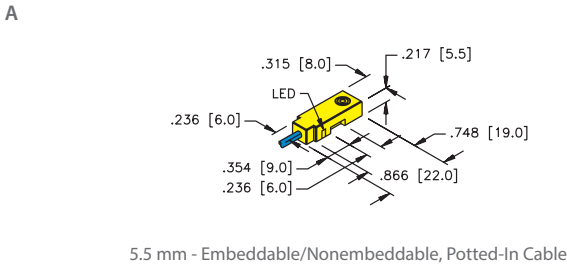

## Wiring Diagrams/Mating Cordsets

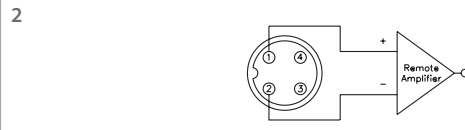
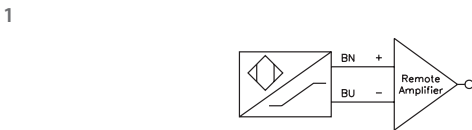

Mating Cordset: RK 4.21T-\*

## A1 2-wire DC NAMUR - (Y0 and Y1)

Differential Travel (Hysteresis):	1-10% (5% typical)
Nominal Voltage:	8.2 VDC (EN60947-5-6)
Load Resistance:	1000 Ω
Non-activated Current Consumption:	≥2.1 mA
Activated Current Consumption:	≤1.2 mA
Recommended Switching Point for Remote Amplifier:	>1.2 to <2.1 mA, typ. 1.55 mA ON/1.75 mA OFF

Power-On Effect:	Realized in Amplifier
Reverse Polarity Protection:	Incorporated
Wire-Break Protection:	Realized in Amplifier
Transient Protection:	Realized in Amplifier
Shock:	30 g, 11 ms
Vibration:	55 Hz, 1 mm Amplitude in all 3 Planes
Repeatability:	≤2% of Rated Operating Distance

### Amplifier Note:

Inductive sensors with Namur outputs are typically used in hazardous locations and the approval agencies require the use of an amplifier to regulate the signals in the hazardous area. Due to the wide variety of approvals, output options, and amplifier designs, it is not possible to incorporate all of the choices in this catalog. For the most up to date information, please either search for these products under our interface technology product category ([www.turck.us](http://www.turck.us)) or contact us by phone.

We reserve the right to make technical alterations without prior notice.

# Rectangular Inductive Sensors | Namur

Intrinsically Safe

Part Number/ ID Number	Features	Embeddable	Sensing Range (mm)	Output	Voltage	Switching Freq. (Hz)	Operating Current (mA)	Operating Temp. (°C)	Protection	Housing	Front Cap/Face	Power LED	Output LED	Cable Length/Jacket	Dimension Drawings	Wiring Diagrams	Spec List
Bi2-Q5.5K-Y1X 4055300		•	2	2-wire DC NAMUR	8.2 VDC nominal	2000	Remote	-25 to +70	IP67	PP	PP	N/A	YE	2M/TPU	A	1	A1
Bi5-Q08-Y1X 4054000		•	5	2-wire DC NAMUR	8.2 VDC nominal	1000	Remote	-25 to +70	IP67	Zinc	PA 12	N/A	YE	2M/TPU	B	1	A1
Bi2-Q10S-Y1X 4012130		•	2	2-wire DC NAMUR	8.2 VDC nominal	1000	Remote	-25 to +70	IP67	PP-GF20	PP-GF20	N/A	YE	2M/PVC	C	1	A1
Bi10-Q14-Y1X 1608730		•	10	2-wire DC NAMUR	8.2 VDC nominal	1000	Remote	-25 to +70	IP67	PBT	PBT	N/A	YE	2M/TPU	D	1	A1
Bi15-Q20-Y1X 1080020		•	15	2-wire DC NAMUR	8.2 VDC nominal	1000	Remote	-25 to +70	IP67	PBT	PBT	N/A	YE	2M/TPU	E	1	A1
Bi15-Q20-Y1X-H1141 1080025		•	15	2-wire DC NAMUR	8.2 VDC nominal	1000	Remote	-25 to +70	IP67	PBT	PBT	N/A	YE	--	F	2	A1

We reserve the right to make technical alterations without prior notice.

Rectangular Inductive Sensors



# Rectangular Inductive Sensors | Namur



## Dimension Drawings

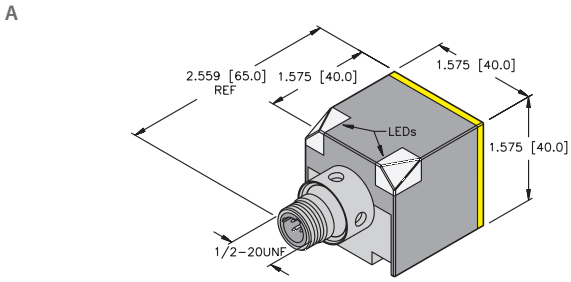

CK40 - Embeddable/Nonembeddable, Eurofast Connector

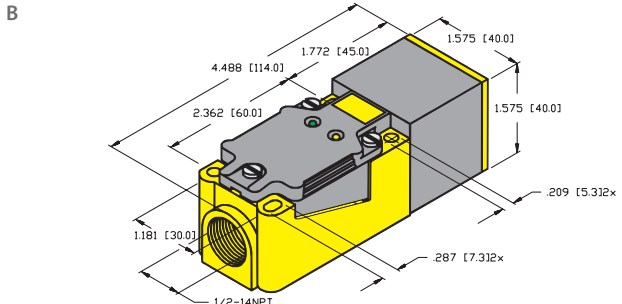

CP40 - Embeddable/Nonembeddable, Terminal Chamber

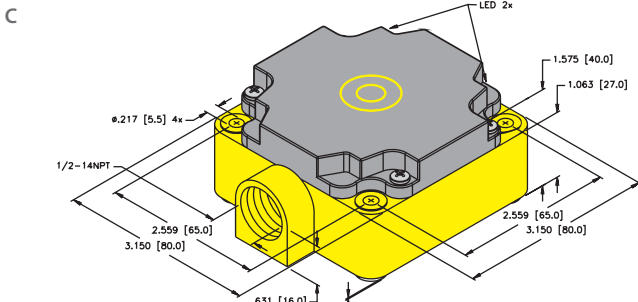

CP80 - Embeddable/Nonembeddable, Terminal Chamber

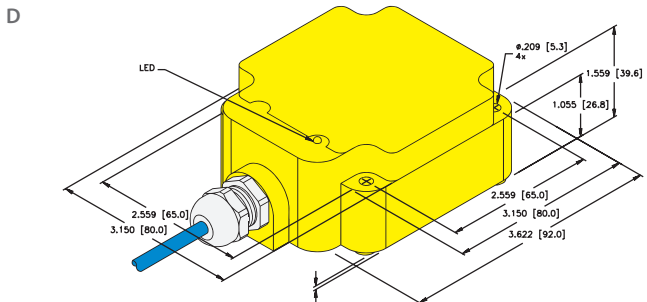

Q80 - Nonembeddable, Potted-In Cable

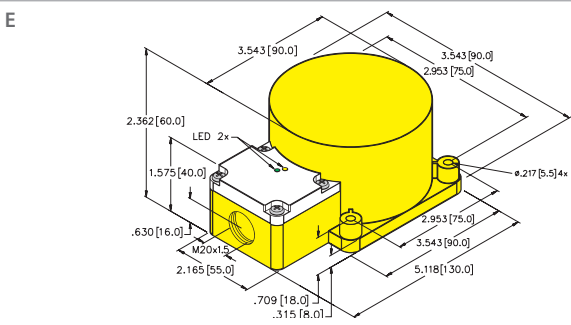

K90SR - Nonembeddable, Terminal Chamber

We reserve the right to make technical alterations without prior notice.

## Wiring Diagrams/Mating Cordsets

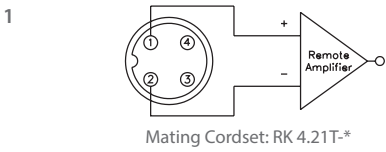

Mating Cordset: RK 4.21T-\*

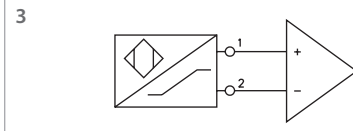
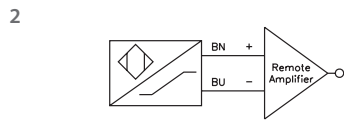

## A1 2-wire DC NAMUR - (Y0 and Y1)

Differential Travel (Hysteresis):	1-10% (5% typical)
Nominal Voltage:	8.2 VDC (EN60947-5-6)
Load Resistance:	1000 Ω
Non-activated current consumption:	≥2.1 mA
Activated current consumption:	≤1.2 mA
Recommended Switching Point for Remote Amplifier:	>1.2 to <2.1 mA, typ. 1.55 mA ON/1.75 mA OFF

Power-On Effect:	Realized in Amplifier
Reverse Polarity Protection:	Incorporated
Wire-Break Protection:	Realized in Amplifier
Transient Protection:	Realized in Amplifier
Shock:	30 g, 11 ms
Vibration:	55 Hz, 1 mm Amplitude in all 3 Planes
Repeatability:	≤2% of Rated Operating Distance

### Amplifier Note:

Inductive sensors with Namur outputs are typically used in hazardous locations and the approval agencies require the use of an amplifier to regulate the signals in the hazardous area. Due to the wide variety of approvals, output options, and amplifier designs, it is not possible to incorporate all of the choices in this catalog. For the most up to date information, please either search for these products under our interface technology product category ([www.turck.us](http://www.turck.us)) or contact us by phone.

# Rectangular Inductive Sensors | Namur

Intrinsically Safe

Part Number/ ID Number	Features	Embeddable	Sensing Range (mm)	Output	Voltage	Switching Freq. (Hz)	Operating Current (mA)	Operating Temp. (°C)	Protection	Housing	Front Cap/Face	Power LED	Output LED	Cable Length/Jacket	Dimension Drawings	Wiring Diagrams	Spec List
<b>Bi15-CK40-Y1X-H1141</b> 4065000		•	15	2-wire DC NAMUR	8.2 VDC nominal	150	Remote	-25 to +70	IP67	PBT	PBT	N/A	YE	--	A	1	A1
<b>Bi15-CP40-Y1X/S10</b> 10120		•	15	2-wire DC NAMUR	8.2 VDC nominal	150	Remote	-25 to +70	IP67	PBT	PBT	N/A	YE	--	B	3	A1
<b>Ni20-CP40-Y1X/S10</b> 10121			20	2-wire DC NAMUR	8.2 VDC nominal	150	Remote	-25 to +70	IP67	PBT	PBT	N/A	YE	--	B	3	A1
<b>Ni35-CP40-Y1X/S100-S10</b> 1011126	High Temp. 100 °C		35	2-wire DC NAMUR	8.2 VDC nominal	80	Remote	-25 to +100	IP67	PBT	PBT	N/A	YE	--	B	3	A1
<b>Ni50-CP80-Y1/S10</b> 10401			50	2-wire DC NAMUR	8.2 VDC nominal	100	Remote	-25 to +70	IP67	PBT	PBT	N/A	N/A	--	C	3	A1
<b>Ni60-Q80-Y1X</b> 1008700			60	2-wire DC NAMUR	8.2 VDC nominal	100	Remote	-25 to +70	IP67	PBT	PBT	N/A	YE	2M/ PVC	D	2	A1
<b>Ni50-K90SR-Y1</b> 10074			50	2-wire DC NAMUR	8.2 VDC nominal	100	Remote	-25 to +70	IP67	PBT	PBT	N/A	N/A	--	E	3	A1

We reserve the right to make technical alterations without prior notice.

Rectangular Inductive Sensors

# Notes



Notes

