

Linear Position Technology

Draw Wire Mechanics with Encoder or Analog Sensor

Draw Wire Encoder DW135



Wide temperature range



Reverse polarity protection

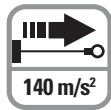

Max acceleration
140 m/s²

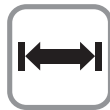

Long service life



High protection level
IP

Robust

- **Corrosion resistant:** Titanium-anodized aluminium housing.
- **High-strength stainless steel draw wire.**
- **Low friction design or wire exit free from wear:** Diamond-polished ceramic guide.
- **Wide temperature range.**

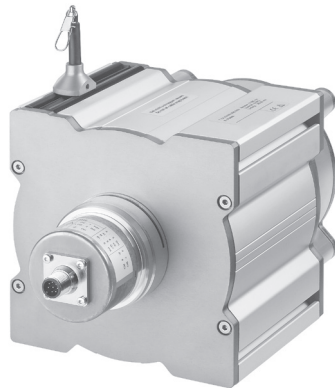

SAE J1939
EtherNet/IP

Versatile

- **Suitable for various sensors/encoders:** Absolute, fieldbus, incremental and analog.
- **Quick mounting:** Fastening by means of mounting feet.
- **Flexible connection options:** Cable, connector, radial, axial.
- **Linearity up to 0.05%.**

Dynamic

- **High traverse speed.**
- **High acceleration:** Dynamic spring traction by means of a constant force spring.

Mechanical Characteristics (Draw Wire Mechanics):

Measuring range:	8,000 mm	10,000-15,000 mm	20,000 mm	25,000-30,000 mm	35,000-42,500 mm
Extension force:	Fmin	1.62 lbs (7.2 N)	1.96 lbs (8.7 N)	1.57 lbs (7.0 N)	1.57 lbs (7.0 N)
	Fmax	3.60 lbs (16.0 N)	3.80 lbs (16.9 N)	2.79 lbs (12.4 N)	3.17 lbs (14.1 N)
Max. speed:	32.8 ft/s (10 m/s)	19.7 ft/s (6 m/s)	16.4 ft/s (5 m/s)	16.4 ft/s (5 m/s)	16.4 ft/s (5 m/s)
Max. acceleration:	459.3 ft/s ² (140 m/s ²)	262.5 ft/s ² (80 m/s ²)	196.8 ft/s ² (60 m/s ²)	196.8 ft/s ² (60 m/s ²)	196.8 ft/s ² (60 m/s ²)
Linearity:	analog output: ±0.1% (of the measuring range) encoder: ±0.05% (of the measuring range)				
Weight:	approx. 1.65 lbs (750 g) (depending on the sensor/encoder used)				
Materials:	housing: titanium-anodized aluminium wire: stainless steel Ø 0.5 mm				
Protection (encoder only):	IP65				

Operating Principle:

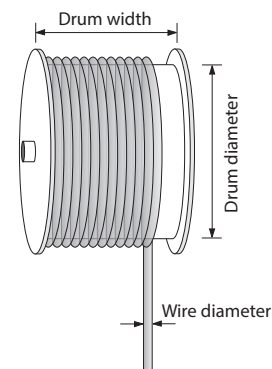

Construction:

The core of a draw wire device is a drum mounted on bearings, onto which a wire is wound. Winding takes place via a spring-loaded device.

Note:

Exceeding the maximum extension length of the draw wire will lead to damage to the wire and the mechanics.

Draw Wire Encoder DW135

Electrical Characteristics (Analog Output, Scaled to Measuring Range):

Analog output [Key Code]:	0-10 V [8C]	4-20 mA [7E]	Potentiometer [PA]
Output:	0-10 V galvanically isolated, 4 conductors	4-20 mA, 2 conductors	1 kOhm
Supply voltage:	12-30 VDC	12-30 VDC	max. 30 VDC
Recommended slider current:	-	-	< 1 μ A
Max. current consumption:	22.5 mA (no load)	50 mA	-
Reverse polarity protection:	yes	yes	-
Operating temperature:	-4 to +185 °F (-20 to +85 °C)	-4 to +185 °F (-20 to +85 °C)	-4 to +185 °F (-20 to +85 °C)

Connection diagrams:

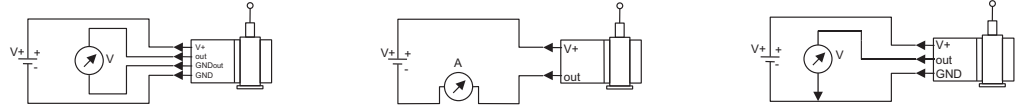

ROHS compliant according to EU guideline 2011/65/EU

Part Number Key: DW135 with Encoder

A	B	C	D	E	F	G	H					
DW	8000	-	135	-	10	-	2B	2000	-	H1181	/	Specials

A	Type
DW	Draw Wire

B	Measuring Range
8000	8000 mm Steel Wire
10000	10000 mm Steel Wire
12000	12000 mm Steel Wire
15000	15000 mm Steel Wire
20000	20000 mm Steel Wire
25000	25000 mm Steel Wire
30000	30000 mm Steel Wire
35000	35000 mm Steel Wire
40000	40000 mm Steel Wire
42500	42500 mm Steel Wire

C	Housing
135	135 mm

D	Encoder Type
10	RI-10, Incremental
28	RM-28, Absolute, SSI
29	RM-29, Absolute, CANopen, EtherCAT, PROFIBUS-DP, PROFINET IO
103	RM-103, Absolute, SSI
105	RM-105, Absolute, CANopen, Ethernet/IP, Modbus
118	RM-118, Absolute, SSI
121	RM-121, Absolute, CANopen, SAE J1939

E	Voltage Supply and Output Type
	Dependent on Encoder Selected ¹⁾

F	Pulse Rate/Resolution
	Dependent on Encoder Selected ¹⁾

G	Type of Connection
	Dependent on Encoder Selected ¹⁾

H	Specials
	Dependent on Encoder Selected ¹⁾

¹⁾Recommended encoders listed below

Linear Position Technology

Draw Wire Mechanics with Encoder or Analog Sensor

Draw Wire Encoder DW135

Standard resolutions for draw wire with incremental encoder RI-10

Drum circumference (mm)	333.33	333.33	333.33
Encoder PPR	1000	2000	4000
Pulses/mm	3	6	12
Resolution (mm)	0.33	0.17	0.08

Standard resolutions for draw wire with absolute encoder RM-118 or RM-121 (12-bit ST, programmable via bus)

Drum circumference (mm)	333.33
Pulses/revolution (ppr)	4096
Pulses/mm	12.3
Resolution (mm)	0.08

Recommended standard variants (with incremental, absolute encoder)

Draw wire assembly	Mounted encoder	Interface	Power supply	Type of connection	Resolution / Protocol	Option
DWxxxx-135-10-2B2000-H1181	RI-10T10C-2B2000-H1181	Push-pull with inverted signal	10-30 VDC	Radial M12 connector	2000 ppr	-
DWxxxx-135-118-3C12S12M-H1181	RM-118T10C-3C12S12M-H1181	SSI	10-30 VDC	Radial M12 connector	4096 ppr / SSI-Gray-Code	-
DWxxxx-135-121-9D38B-H1151	RM-121T10C-9D38B-H1151	CANopen	10-30 VDC	Radial M12 connector	CANopen encoder profile DS406 V4.0	-

Other variants (with absolute encoder)

Draw wire assembly	Mounted encoder	Interface	Power supply	Type of connection	Resolution / Protocol	Option
DWxxxx-135-103-3C12S12M-H1181	RM-103T10C-3C12S12M-H1181	SSI	10-30 VDC	1 x radial M12 connector	4096 ppr / SSI-Gray-Code	SET button + status LED
DWxxxx-135-28-3C24B-H1181	RM-28T10C-3C24B-H1181	SSI	10-30 VDC	1 x radial M12 connector	4096 ppr / SSI-Gray-Code	SET button + status LED
DWxxxx-135-105-9D38B-H1151/N46	RM-105T10C-9D38B-B1M12/N46	CANopen	10-30 VDC	1 x radial M12 connector	CANopen encoder profile DS406 V3.2	SET button
DWxxxx-135-29-9D28B-R2M12/N46	RM-29T10C-9D28B-R2M12/N46	CANopen	10-30 VDC	2 x radial M12 connector	CANopen encoder profile DS406 V3.2	SET button
DWxxxx-135-121-9F43B-H1151	RM-121T10C-9F43B-H1151	SAE J1939	10-30 VDC	1 x radial M12 connector	CAN high-speed acc. to ISO 11898, CAN specification 2.0 B	-
DWxxxx-135-29-9A28B-R3M12/N46	RM-29T10C-9A28B-R3M12/N46	PROFIBUS	10-30 VDC	3 x radial M12 connector	Profibus-DP V0 encoder profile Class 2	SET button
DWxxxx-135-29-9C28B-R3M12	RM-29T10C-9C28B-R3M12	EtherCAT	10-30 VDC	3 x radial M12 connector	EtherCAT with CoE 3.2.10	-
DWxxxx-135-29-9E28B-R3M12	RM-29T10C-9E28B-R3M12	PROFINET IO	10-30 VDC	3 x radial M12 connector	PROFINET encoder profile version 4.1	-
DWxxxx-135-105-9N32B-B3M12	RM-105T10C-9N32B-B3M12	EtherNet/IP	10-30 VDC	3 x axial M12 connector	EtherNet/IP	-

Linear Position Technology

Draw Wire Mechanics with Encoder or Analog Sensor

Draw Wire Encoder DW135

Part Number Key: DW135 with Encoder (analog, scalable with limit switch function)

A	B		C		D		E	F		G		H
DW	8000	-	135	-	116	-	7A	SALNS	-	H1151	/	Specials

A	Type
DW	Draw Wire

D	Encoder Type
116	RM-116, Absolute

B	Measuring Range
8000	8000 mm Steel Wire
10000	10000 mm Steel Wire
12000	12000 mm Steel Wire
15000	15000 mm Steel Wire
20000	20000 mm Steel Wire
25000	25000 mm Steel Wire
30000	30000 mm Steel Wire
35000	35000 mm Steel Wire
40000	40000 mm Steel Wire
42500	42500 mm Steel Wire

E	Voltage Supply and Output Type
	Dependent on Encoder Selected ¹⁾

F	Type of Connection
	Dependent on Encoder Selected ¹⁾

G	Pulse Rate/Resolution
	Dependent on Encoder Selected ¹⁾

¹⁾Recommended encoders listed below

C	Housing
135	135 mm

Linear Position Technology

Recommended standard variants (with analog encoder, scalable with limit switch function)

Draw wire assembly	Mounted encoder	Interface	Power supply	Type of connection	Resolution / Protocol	Option
DWxxxx-135-116-7ASALNS-H1151	RM-116T10C-7ASALNS-H1151	Analog, 4-20 mA	10-30 VDC	Radial M12 connector	12 Bit / 4-20 mA	scalable without limit switch function
DWxxxx-135-116-8BSALNS-H1151	RM-116T10C-8BSALNS-H1151	Analog, 0-10 V	15-30 VDC	Radial M12 connector	12 Bit / 0-10 V	scalable without limit switch function
DWxxxx-135-116-7ASALWL-H1151	RM-116T10C-7ASALWL-H1151	Analog, 4-20 mA	10-30 VDC	Radial M12 connector	12 Bit / 4-20 mA	scalable with limit switch function
DWxxxx-135-116-8BSALWL-H1151	RM-116T10C-8BSALWL-H1151	Analog, 0-10 V	15-30 VDC	Radial M12 connector	12 Bit / 0-10 V	scalable with limit switch function

Linear Position Technology

Draw Wire Mechanics with Encoder or Analog Sensor

Draw Wire Encoder DW135

Part Number Key: DW135 with Analog Sensor (scaled to measuring range)

A	B		C		D		E
DW	8000	-	135	-	7E	-	H1441

A	Type
DW	Draw Wire

C	Housing
135	135 mm

B	Measuring Range
8000	8000 mm Steel Wire
10000	10000 mm Steel Wire
12000	12000 mm Steel Wire
15000	15000 mm Steel Wire
20000	20000 mm Steel Wire
25000	25000 mm Steel Wire
30000	30000 mm Steel Wire
35000	35000 mm Steel Wire
40000	40000 mm Steel Wire
42500	42500 mm Steel Wire

D	Voltage Supply and Output Type
7E	12-30 VDC, 4-20 mA
8C	12-30 VDC, 0-10 V
PA	30 VDC max, 1 kΩ, Potentiometer

E	Type of Connection
H1441	Axial 4-pin M12 Eurofast Connector
CA	Axial Cable (2m PVC)

Standard Wiring (analog sensor):

Pin	Color	0-10 V	4-20 mA	1 kOhm
1	BN	V+	V+	V+
2	WH	Signal	N/C	Slider
3	BU	GND	Signal	GND
4	BK	GND Sig.	N/C	N/C

Wiring Diagram:

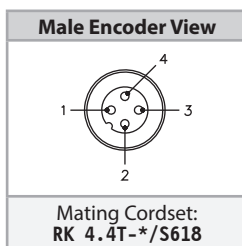

* Length in meters.

Draw Wire Encoder DW135

Dimensions: D135 with Encoder, Measuring Range 8,000 mm

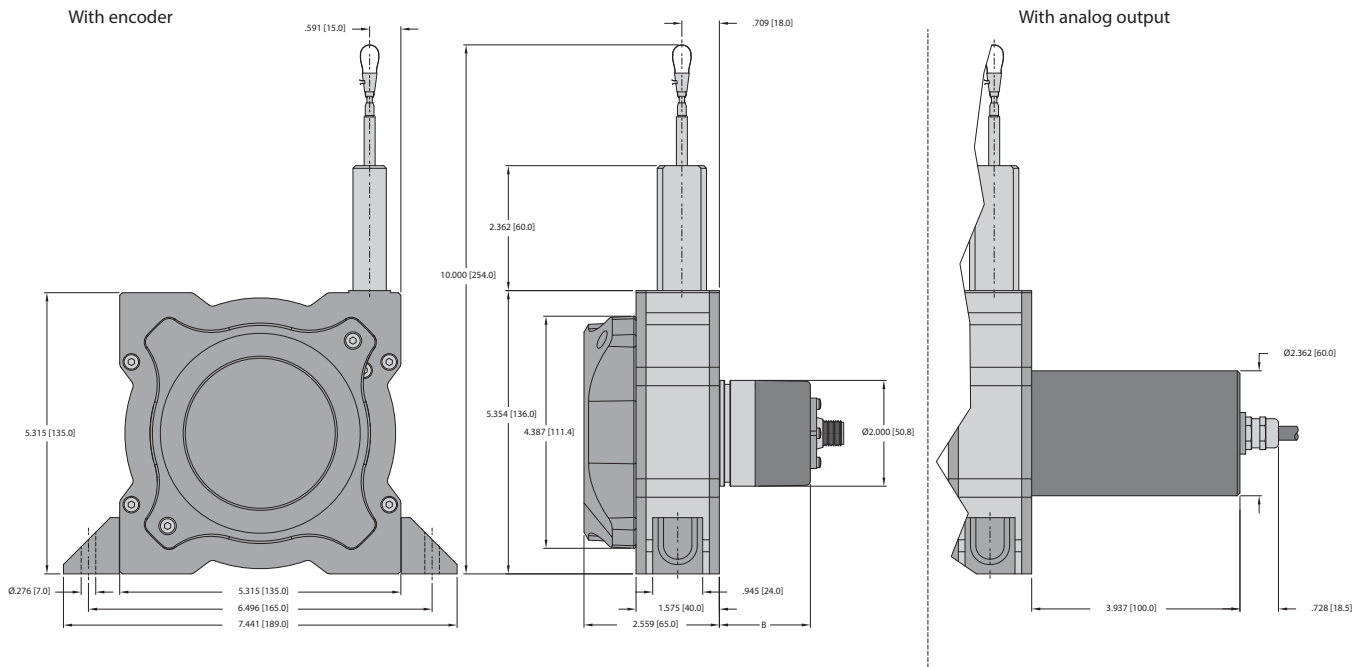

Linear Position Technology

Dimension B depends on the encoder used

Encoder	Draw wire assembly	B in. [mm]
Incremental (RI-10)	DW****-135-10-*****_****	1.46 [37.0]
Absolute (RM-28)	DW****-135-28-*****_****	1.95 [49.5]
Absolute (RM-29)	DW****-135-29-*****_****	3.04 [77.2]
Absolute (RM-103)	DW****-135-103-*****_****	1.95 [49.5]
Absolute (RM-105) [CANopen]	DW****-135-105-*****_****	2.76 [70.0]
Absolute (RM-105) [EtherNet/IP]	DW****-135-105-*****_****	2.34 [59.5]
Absolute (RM-116)	DW****-135-116-*****_****	1.96 [49.8]
Absolute (RM-118)	DW****-135-118-*****_****	1.96 [49.8]
Absolute (RM-121)	DW****-135-121-*****_****	1.96 [49.8]

Dimensions: DW135 with Encoder, Measuring Range 10,000 - 12,000 mm

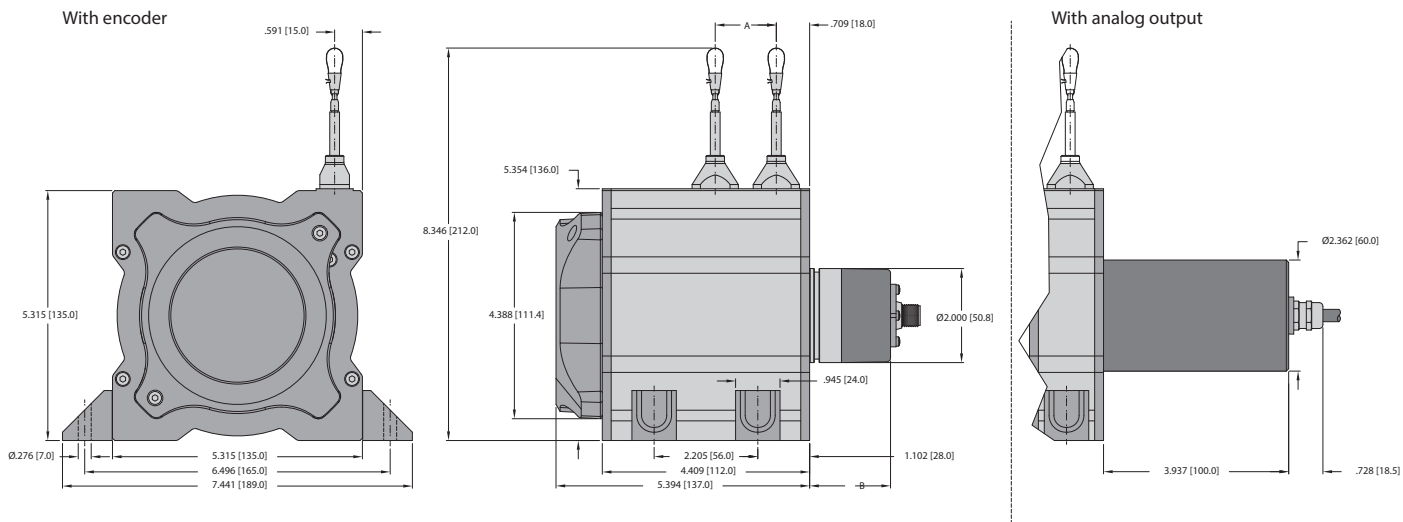

Linear Position Technology

Draw Wire Mechanics with Encoder or Analog Sensor

Draw Wire Encoder DW135

Dimensions: DW135 with Encoder, Measuring Range 15,000 - 20,000 mm

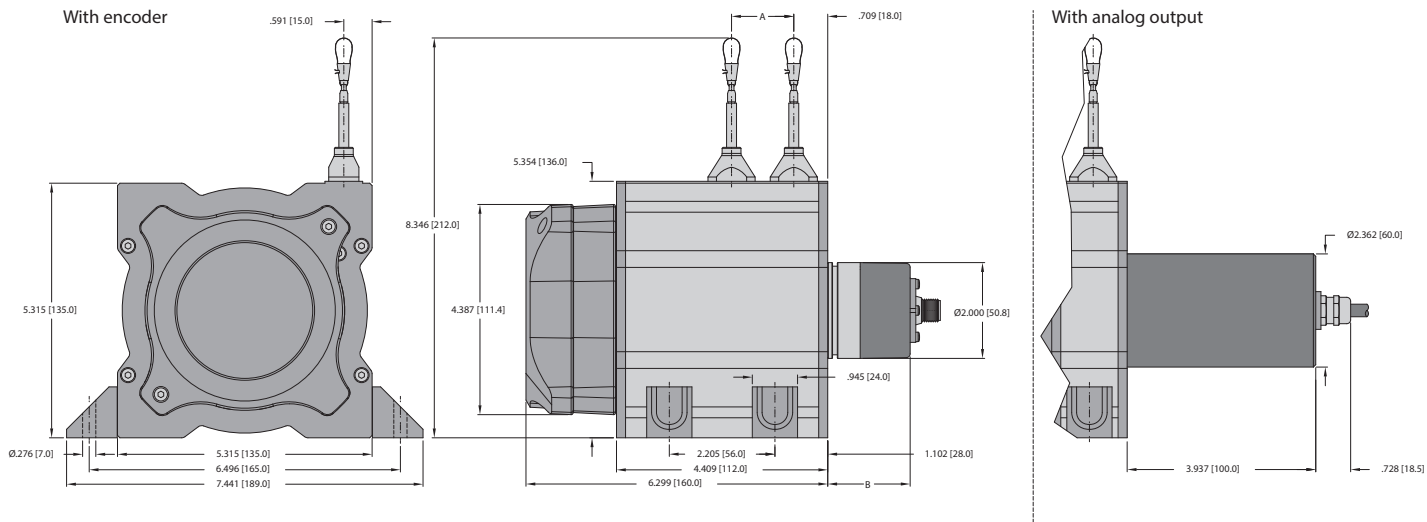

Measuring range	A - Wire rolled up	Wire pulled out
10000 mm	1.30 [33]	0.71 [18]
12000 mm	1.42 [36]	0.71 [18]
15000 mm	1.61 [41]	0.71 [18]
20000 mm	1.89 [48]	0.71 [18]

Dimension B depends on the encoder used

Encoder	Draw wire assembly	B in. [mm]
Incremental (RI-10)	DW*****-135-10-*****_*****	2.36 [60.0]
Absolute (RM-28)	DW*****-135-28-*****_*****	2.85 [72.5]
Absolute (RM-29)	DW*****-135-29-*****_*****	2.85 [72.5]
Absolute (RM-103)	DW*****-135-103-*****_*****	3.94 [100.2]
Absolute (RM-105) [CANopen]	DW*****-135-105-*****_*****	3.66 [93.0]
Absolute (RM-105) [EtherNet/IP]	DW*****-135-105-*****_*****	3.25 [82.5]
Absolute (RM-116)	DW*****-135-116-*****_*****	2.87 [72.8]
Absolute (RM-118)	DW*****-135-118-*****_*****	2.87 [72.8]
Absolute (RM-121)	DW*****-135-121-*****_*****	2.87 [72.8]

Dimensions: DW135 with Encoder, Measuring Range 25,000 - 30,000 mm

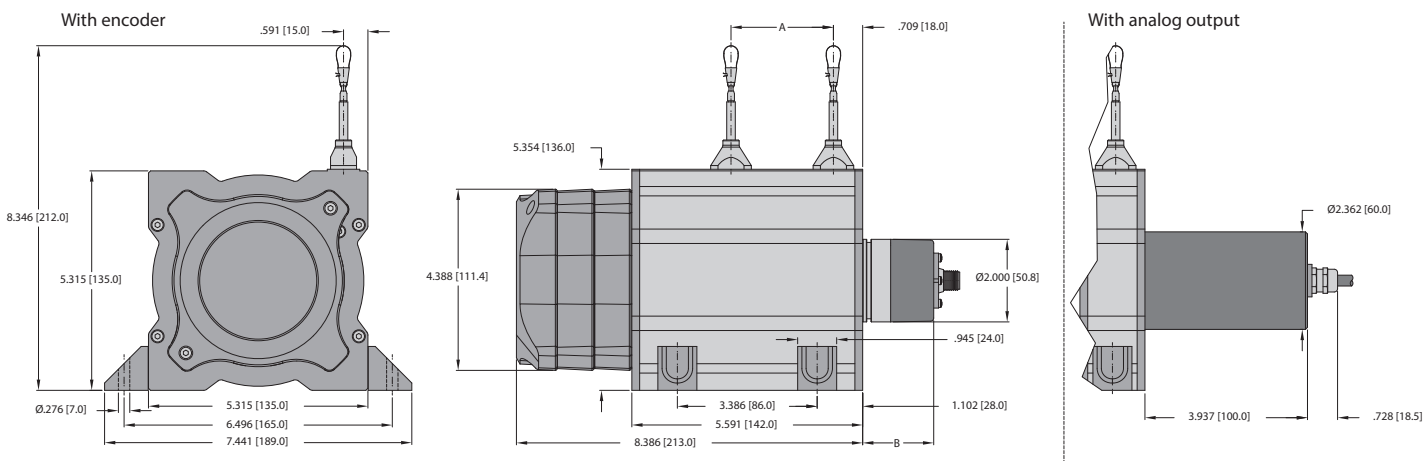

Draw Wire Encoder DW135

Dimensions: DW135 with Encoder, Measuring Range 35,000 - 42,500 mm

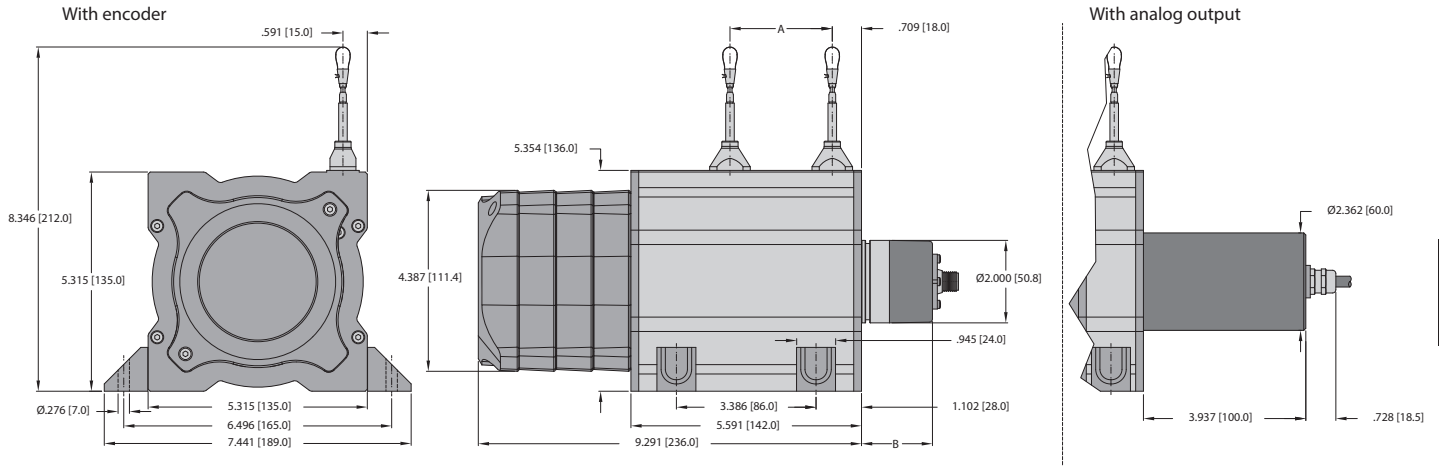

Dimension B depends on the encoder used

Measuring range	A - Wire rolled up	Wire pulled out
25000 mm	2.02 [56]	0.71 [18]
30000 mm	2.48 [63]	0.71 [18]
35000 mm	2.80 [71]	0.71 [18]
40000 mm	3.07 [78]	0.71 [18]
42500 mm	3.23 [82]	0.71 [18]

Encoder	Draw wire assembly	B in. [mm]
Incremental (RI-10)	DW*****_135-10-*****_*****	2.36 [60.0]
Absolute (RM-28)	DW*****_135-28-*****_*****	2.85 [72.5]
Absolute (RM-29)	DW*****_135-29-*****_*****	2.85 [72.5]
Absolute (RM-103)	DW*****_135-103-*****_*****	3.94 [100.2]
Absolute (RM-105) [CANopen]	DW*****_135-105-*****_*****	3.66 [93.0]
Absolute (RM-105) [EtherNet/IP]	DW*****_135-105-*****_*****	3.25 [82.5]
Absolute (RM-116)	DW*****_135-116-*****_*****	2.87 [72.8]
Absolute (RM-118)	DW*****_135-118-*****_*****	2.87 [72.8]
Absolute (RM-121)	DW*****_135-121-*****_*****	2.87 [72.8]

Linear Position Technology

Accessories:

- See page H1, Connectivity, for cables and connectors