

Incremental Type RI-10 (Shaft) / RI-12 (Hollow Shaft)



Versatile

- **The right connection for every application:** Cable, M12 connector, M23 connector, and Mil-Spec Connectors.
- **Wide variety of standard industrial mounting options:** Servo, square, clamping flanges.
- **Standardized designs for worldwide use:** Compatible with US and European standards; 5-30 V supplies; Various output options; Up to 5,000 ppr.



Compact

- **Small footprint:** Outer diameter 2" x 2" Can utilize 2" or 2.5" flanges.

Rugged and Tough

- **High tolerance to vibration, shock and alignment issues:** Sturdy double bearing lock design.
- **Environmentally protected design:** Die-cast housings; butyl rubber shaft seals and O-rings; robust stainless steel hubs, flanges, and disc tables. Ratings up to IP67.
- **Wide temperature range:** -40 to +185 °F (-40 to +85 °C)
- Also available in seawater resistant version, certified acc. to salt-spray test IEC 68-2-11 ≥ 672 hours

Mechanical Characteristics:

Speed IP65 ¹⁾ :	max. 12,000 RPM	Weight:	approx. 0.9 lbs (0.4 kg)
Speed IP67 ²⁾ :	max. 6,000 RPM	Protection acc. to EN 60 529 without shaft sealing:	IP65
Rotor moment of inertia:	Shaft: approx. 0.098 oz-in ² (1.8 x 10 ⁻⁶ kgm ²)	Protection acc. to EN 60 529 with shaft sealing:	IP67
	Hollow shaft: approx. 0.328 oz-in ² (6.0 x 10 ⁻⁶ kgm ²)	Working temperature ³⁾ :	-40 to +185 °F (-40 to +85 °C)
Starting torque:	< 1.4 oz-in (< 0.01 Nm), IP65 < 7 oz-in (< 0.05 Nm), IP67	Shaft:	stainless steel
Radial load capacity of the shaft:	18 lbs (80 N)	Shock resistance acc. to EN 60068-2-27:	250 g (2,500 m/s ²), 6 ms
Axial load capacity of the shaft:	9 lbs (40 N)	Vibration resistance to EN 60068-2-6:	10 g (100 m/s ²), 10-2,000 Hz

¹⁾ For continuous operation 6000 RPM
²⁾ For continuous operation max. 3000 RPM
³⁾ With connector: -40 °F (-40 °C), cable fixed: -22 °F (-30 °C), cable moved: -4 °F (-20 °C)

Electrical Characteristics:

Output circuit [Key Code]:	RS 422 [4B] (TTL compatible)	RS 422 [4A] (TTL compatible)	Push-Pull [2B]	Push-Pull [2K] (7272 compatible) ³⁾	Open Collector [CA] (7273) ³⁾
Supply voltage:	5-30 VDC	5 V ±5%	10-30 V DC	5-30 V DC	5-30 V DC
Power consumption (no load):	typ. 40 mA max. 90 mA	typ. 40 mA max. 90 mA	typ. 50 mA max. 100 mA	typ. 50 mA max. 100 mA	100 mA
Permissible load/channel:	max. ±20 mA	max. ±20 mA	max. ±20 mA	max. ±20 mA	20 mA sink@30 VDC
Pulse frequency:	max. 300 kHz	max. 300 kHz	max. 300 kHz	max. 300 kHz	max. 300 kHz
Signal level high:	min. 2.5 V	min. 2.5 V	min. +V -1.0 V	min. +V -2.0 V	n/a
Signal level low:	max. 0.5 V	max. 0.5 V	max. 0.5 V	max. 0.5 V	n/a
Rise time t _r :	max. 200 ns	max. 200 ns	max. 1 μs	max. 1 μs	
Fall time t _f :	max. 200 ns	max. 200 ns	max. 1 μs	max. 1 μs	
Short-circuit protected ¹⁾ :	yes ²⁾⁴⁾	yes ²⁾⁴⁾	yes	yes ²⁾⁴⁾	yes
Reverse polarity protection:	yes	no	yes	no	no
UL approval:	file E356899				
RoHS compliant acc. to EU guideline 2011/65/EU					

¹⁾ If supply voltage correctly applied
²⁾ Only one channel allowed to be shorted-out: (If +V=5 V, short-circuit to channel, 0 V, or +V is permitted.) (If +V=5-30 V, short-circuit to channel or 0 V is permitted.)
³⁾ Max. recommended cable length 30 m
⁴⁾ Approximately one minute

Incremental Encoders

Rotary Position Technology

Incremental Encoders

Incremental Type RI-10 (Shaft) / RI-12 (Hollow Shaft)

Standard Wiring :

Connection Type	Case Ground	Common (0V)	+V	A	\bar{A}	B	\bar{B}	Z	\bar{Z}	N/C	N/C	0V ¹⁾ Sens	+V ²⁾ Sens
M23 Multifast	Coupling Nut	10	12	5	6	8	1	3	4	-	-	11	2
MS 6-pin	-	A	B	E	-	D	-	C	-	-	-		
MS 7-pin	G	F	D	A	-	B	-	C	-	-	-		E
MS 10-pin	J	F	D	A	G	B	H	C	I	-	-		E
M12 Eurofast 8-pin	Coupling Nut	1	2	3	4	5	6	7	8	-	-		
M12 Eurofast 5-pin	Coupling Nut	3	1	4	-	2	-	5	-	-	-		
Cable	Shield/Drain	WH	BN	GN	YE	GY	PK	BU	RD	BK	VT	GY/PK	RD/BU

¹⁾ The sensor cables are connected to the supply voltage internally. If long feeder cables are involved they can be used to adjust or control the voltage at the encoder.

²⁾ Isolate unused outputs before initial startup.

Special Pin Configuration:

Wiring Code	Connection Type	Case Ground	Common (0V)	+V	A	\bar{A}	B	\bar{B}	Z	\bar{Z}
N41	M12 Eurofast 8-pin	Coupling Nut	7	2	1	3	4	5	6	8
N35	MS 6-pin	-	A, F	B	D	-	E	-	C	-
N38	MS 7-pin	G	F	D	A	C	B	E	-	-
N40	MS 10-pin	G	F	D	A	H	B	I	C	J
N78	M12 Eurofast 5-pin	Coupling Nut	1	2	3	-	4	-	5	-

Wiring Diagrams:

Male Encoder View					
M12 Eurofast Pinout	M12 Eurofast Pinout	M23 Multifast Pinout	MS Pinout (6-pin)	MS Pinout (7-pin)	MS Pinout (10-pin)
Mating Cordset: E-RKC 8T-930-*	Mating Cordset: E-RKC 4.5T-930-*	Mating Cordset: E-CKM 12-931-*	Mating Cordset: E-MK 6-0-*	Mating Cordset: E-MK 7-930-*	Mating Cordset: E-MK 10-931-*

* Length in meters.

Incremental Type RI-10 (Shaft) / RI-12 (Hollow Shaft) Accessories - Inserts

Isolation/Adapter Inserts for Hollow Shaft Encoders



Thermal and Electrical Isolation of the Encoders:

Isolation inserts prevent currents from passing through the encoder bearings. These currents can occur when using inverter controlled three-phase or AC vector motors and considerably shorten the service life of the encoder bearings. In addition, the encoder is thermally isolated as the plastic does not transfer the heat to the encoder.

Tip:

By using these adapter inserts, you can achieve six different hollow shaft diameters, all on the basis of one 15 mm encoder.

Dimensions:

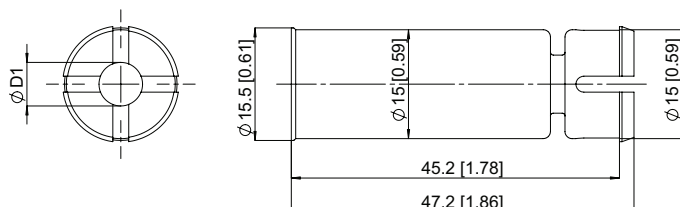

Isolation Insert	D1 [mm]	D1 [in]
RSA-6-12	6	
RSA-A0-12	6.35	(1/4)
RSA-10-12	10	
RSA-A1-12	9.53	(3/8)
RSA-12-12	12	
RSA-A3-12	12.7	(1/2)

Note: Use with 15 mm bore size hollow shaft RI-12 encoder.

Incremental Type RI-10 (Shaft)

Part Number Key: RI-10 Shaft Version

A	B	C		D	E		F		G/H
RI-10S	6	Z2	-	2B	1024	-	H1181	/	Specials

A	Type
RI-10S	Ø 2", Shaft, IP67 Shaft Seal
RI-10T	Ø 2", Shaft, IP65 Shaft Seal

B	Shaft (Ø x L)
6	Ø 6 mm x 10 mm
8	Ø 8 mm x 15 mm
10	Ø 10 mm x 20 mm
12	Ø 12 mm x 20 mm
A0	Ø 1/4" ¹⁾
A1	Ø 3/8" ²⁾

¹⁾ 1/4" x 5/8" for Flange Z2, Z4, C & S. 1/4" x 7/8" for Flange R & S0.
²⁾ 3/8" x 5/8" for Flange Z2, Z4, C & S. 3/8" x 7/8" for Flange R & S0.

C	Flange
Z2	Ø 2" Servo Flange
Z4	2" Square Flange
C	Ø 58 mm Clamping Flange
S	Ø 58 mm Servo Flange
R	2.5" Square Flange
S0	Ø 2.5" Servo Flange

D	Voltage Supply and Output Type
2B	10-30 VDC, Push-Pull
2K	5-30 VDC, Push-Pull (7272 comp. w/o bypass capacitor)
4A	5 VDC, RS422 (TTL compatible)
4B	5-30 VDC, RS422 (TTL compatible)
CA	5-30 VDC, Open Collector

E	Pulse Rate
	1, 2, 4, 5, 10, 12, 14, 20, 25, 28, 30, 32, 36, 50, 60, 64, 80, 100, 120, 125, 150, 180, 200, 240, 250, 256, 300, 342, 360, 375, 400, 500, 512, 600, 625, 720, 800, 900, 1000, 1024, 1200, 1250, 1500, 1800, 2000, 2048, 2500, 3000, 3600, 4000, 4096, 5000 (e.g. 250 Pulses => 250) Other Pulse Rates Available on Request

F	Type of Connection
H1181	Radial 8-pin M12 Eurofast Connector
H1481	Axial 8-pin M12 Eurofast Connector
H1151	Radial 5-pin M12 Eurofast Connector
H1451	Axial 5-pin M12 Eurofast Connector
12M23	Radial 12-pin M23 Multifast® Connector
12M23A	Axial 12-pin M23 Multifast Connector
6MIL	Radial 6-pin MS Connector
7MIL	Radial 7-pin MS Connector
10MIL	Radial 10-pin MS Connector
C1M	Radial Cable (1 m PVC)
CA1M	Axial Cable (1 m PVC)

G	Special Output Signal Formats
	N21 to N33 (See Page E38)

H	Special Connector Pin Configuration
	N35 to N41 (See Page E12)

Accessories:

- See page H1, Connectivity, for cables and connectors
- See page G1, Accessories, for mounting attachments and couplings

Rotary Position Technology

Incremental Encoders

Incremental Type RI-12 (Hollow Shaft)

Part Number Key: RI-12 Hollow Shaft Version

A	B	C		D	E		F		G/H
RI-12H	6	S1	-	2B	1024	-	H1181	/	Specials

A	Type
RI-12H	Ø 2" Hollow Shaft, IP67 Shaft Seal
RI-12I	Ø 2" Hollow Shaft, IP65 Shaft Seal

B	Bore
6	Ø 6 mm
8	Ø 8 mm
10	Ø 10 mm
12	Ø 12 mm
14	Ø 14 mm
15	Ø 15 mm
A0	Ø 1/4"
A1	Ø 3/8"
A3	Ø 1/2"
A4	Ø 5/8"

C	Flange
S1	Flange w/ Long Tether Arm
T	Flange w/ Torque Stop*
E2	Ø 2.25" w/ Flex Mount
E	Ø 63 mm w/ Slotted Flex Mount
E1	Ø 65 mm w/ Flex Mount

* Requires 4 mm torque pin

D	Voltage Supply and Output Type
2B	10-30 VDC, Push-Pull
2K	5-30 VDC, Push-Pull (7272 comp. w/o bypass capacitor)
4A	5 VDC, RS422 (TTL compatible)
4B	5-30 VDC, RS422 (TTL compatible)
CA	5-30 VDC, Open Collector

E	Pulse Rate
	1, 2, 4, 5, 10, 12, 14, 20, 25, 28, 30, 32, 36, 50, 60, 64, 80, 100, 120, 125, 150, 180, 200, 240, 250, 256, 300, 342, 360, 375, 400, 500, 512, 600, 625, 720, 800, 900, 1000, 1024, 1200, 1250, 1500, 1800, 2000, 2048, 2500, 3000, 3600, 4000, 4096, 5000 (e.g. 250 Pulses => 250) Other Pulse Rates Available on Request

F	Type of Connection
H1181	Radial 8-pin M12 Eurofast Connector
H1151	Radial 5-pin M12 Eurofast Connector
12M23	Radial 12-pin M23 Multifast Connector
10MIL	Radial 10-pin MS Connector
C1M	Radial Cable (1 m PVC)
CT1M	Tangential Cable (1 m PVC)
CT0.3M-FSFD5	Tangential Cable w/ 0.3 m M12 Eurofast Connector

G	Special Output Signal Formats
	N21 to N33 (See Page E38)

H	Special Connector Pin Configuration
	N36 - N41 (See Page E12)

Accessories:

- See page H1, Connectivity, for cables and connectors
- See page G1, Accessories, for mounting attachments and couplings

Incremental Type RI-10 (Shaft) / RI-12 (Hollow Shaft)

Dimensions: RI-10 Shaft Version

RI-10 Flange Z2 Connection H11*1 & H14*1

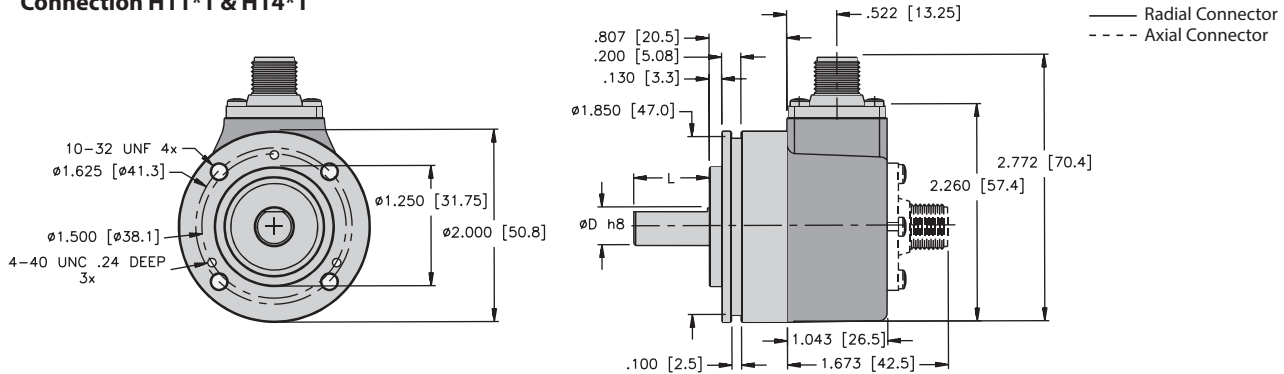

RI-10 Flange Z4 Connection C & CA

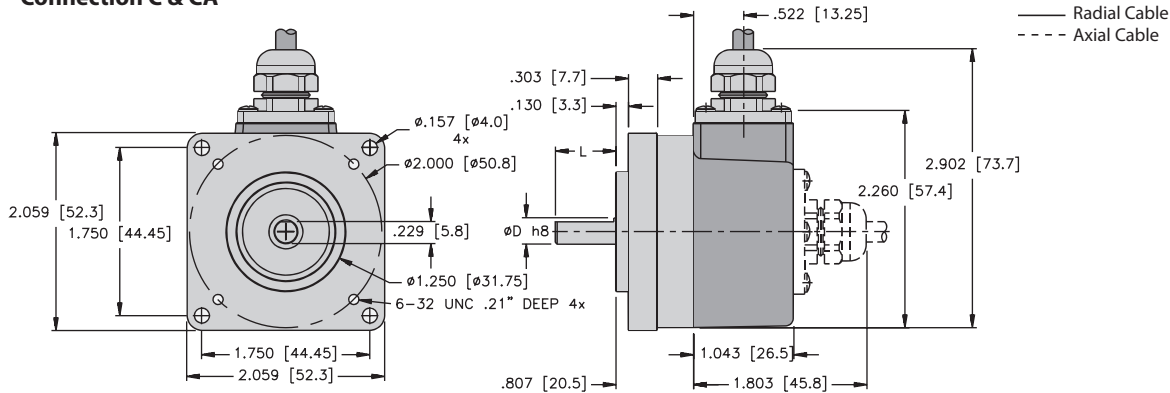

RI-10 Flange R Connection 6 MIL, 7 MIL & 10 MIL

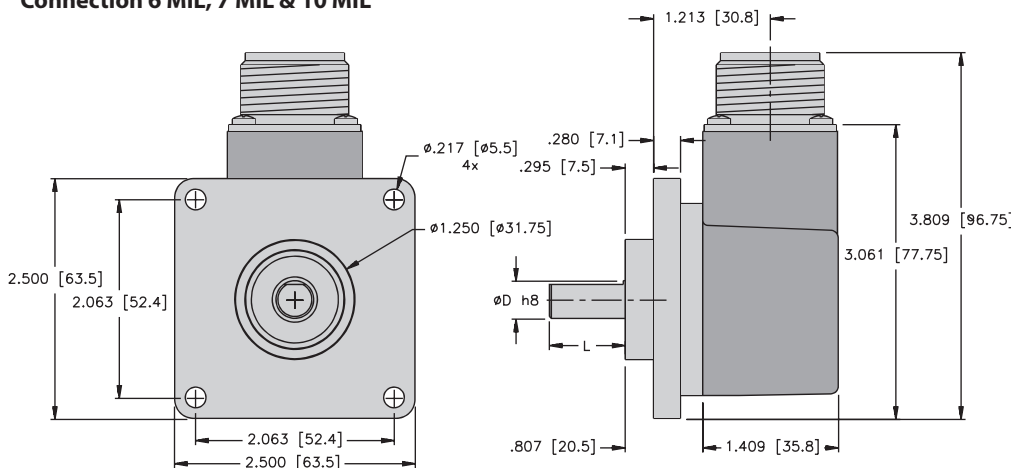

Mounting advice:

The flanges and shafts of the encoder and drive should not be rigidly coupled together at the same time. We recommend the use of suitable couplings (see page G1, Accessories).

Rotary Position Technology

Incremental Encoders

Incremental Type RI-10 (Shaft) / RI-12 (Hollow Shaft)

Dimensions: RI-10 Shaft Version

RI-10 Flange C Connection 12M23 & 12M23A

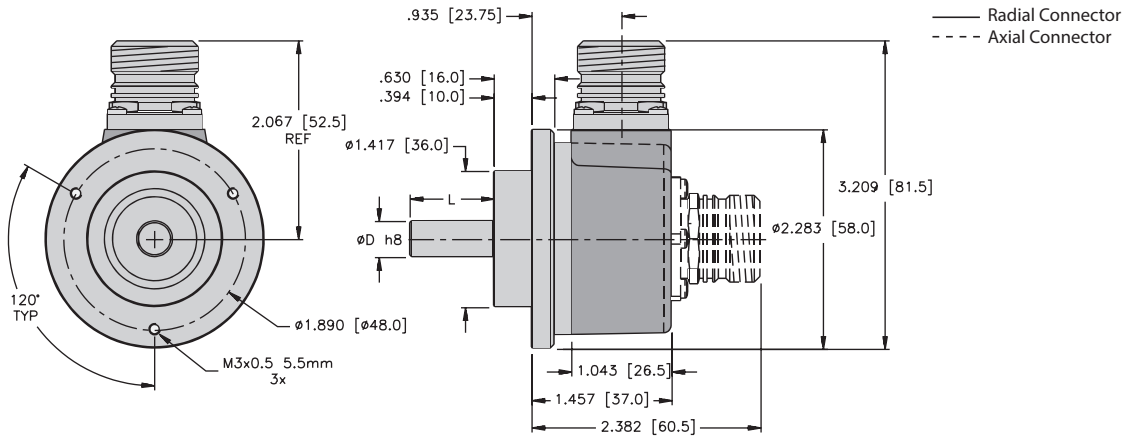

RI-10 Flange S Connection C & CA

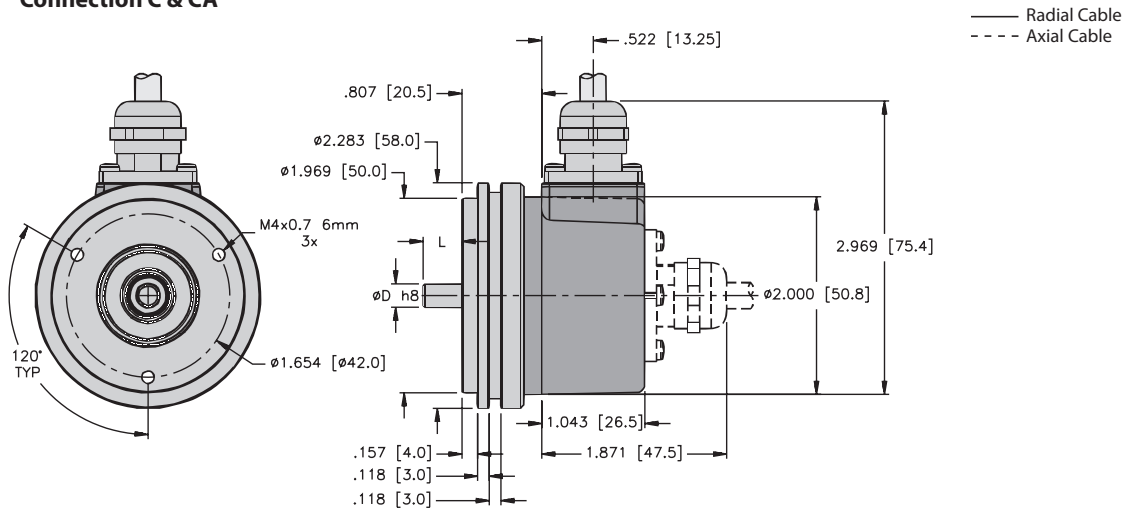

RI-10 Flange S0 Connection H11*1 & H14*1

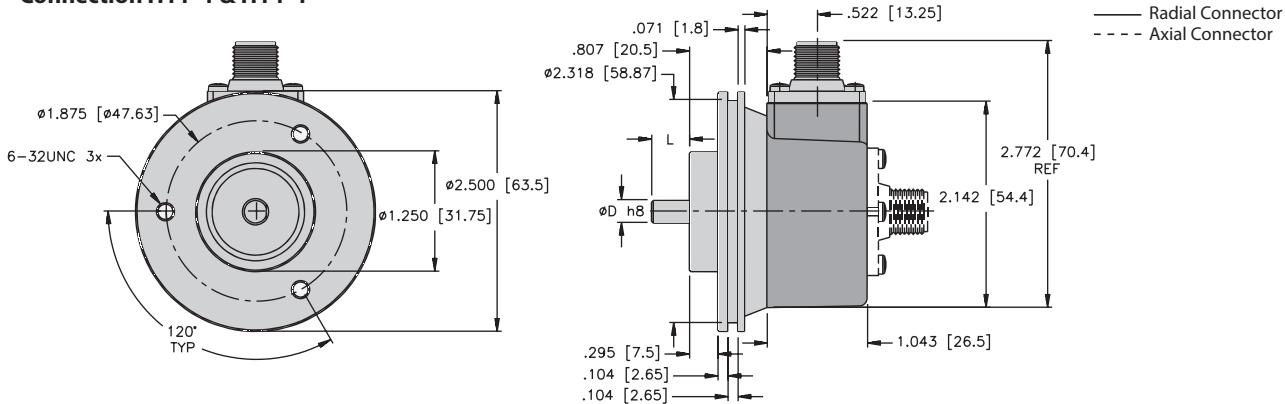

Mounting Advice:

The flanges and shafts of the encoder and drive should not be rigidly coupled together at the same time. We recommend the use of suitable couplings (see page G1, Accessories).

Incremental Type RI-10 (Shaft) / RI-12 (Hollow Shaft)

Dimensions: RI-12 Hollow Shaft Version

RI-12 Flange T Connection C

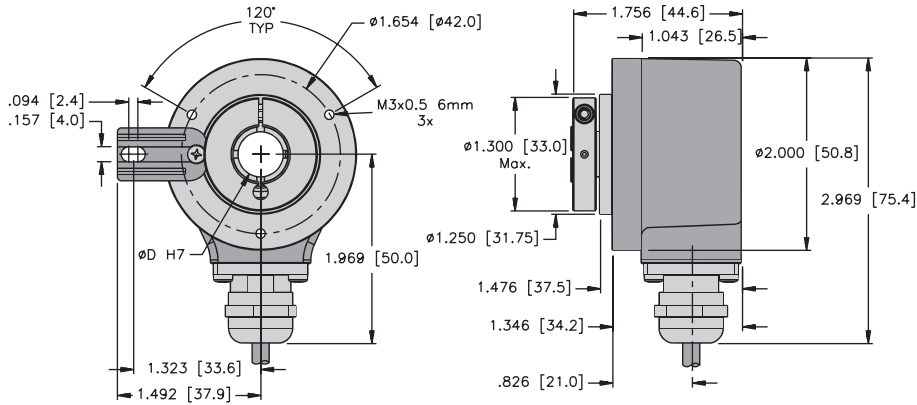

RI-12 Flange S1 Connection H11*1

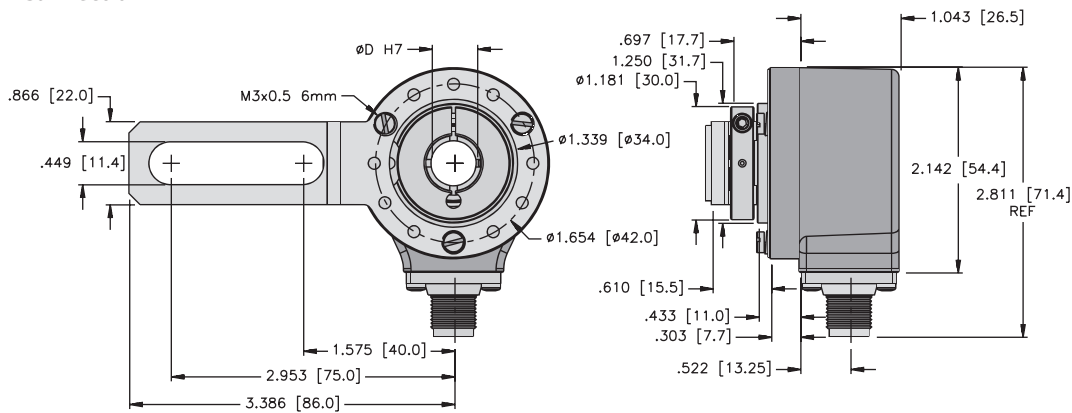

RI-12 Flange E2 Connection 12M23

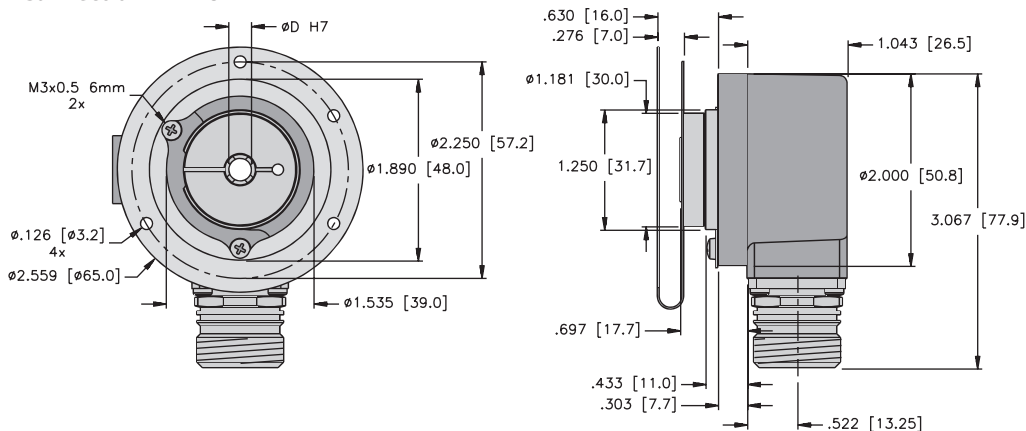

Wave Forms

Outputs

All Turck encoders come standard with six channels, where A leads B in the clockwise direction and the standard index is gated with A & B. The tolerance of the wave form affects the control, and in some cases it may affect the smoothness of system operation.

Wave Form Tolerances

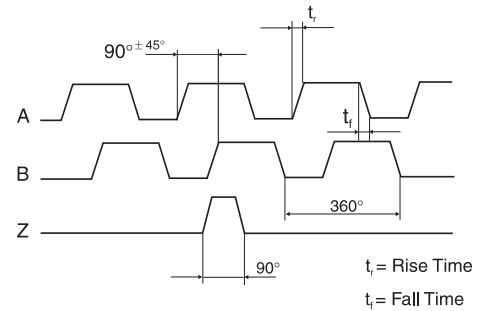

<p>A leads B when the shaft is turned in the clockwise direction viewing the shaft or collet end.</p> <p>This is Turck's standard. This format applies to the pin key codes listed below.</p>		<p>B leads A when the shaft is rotated in the clockwise direction viewing the shaft or collet end.</p> <p>This format applies to the pin key codes listed below.</p>	
<p>A leads B, Z gated with A & B. This is Turck's standard. Z is 90° wide.</p>		<p>Code N24: B leads A, Z gated with A & B. Z is 90° wide.</p>	
<p>Code N21: A leads B, Z gated with B. Z is 180° wide.</p>		<p>Code N25: B leads A, Z gated with B. Z is 180° wide.</p>	
<p>Code N22: A leads B, Z gated with A. Z is 180° wide.</p>		<p>Code N26: B leads A, Z gated with A. Z is 180° wide.</p>	
<p>Code N23: A leads B, Z ungated. Z is 330° to 360° wide.</p>		<p>Code N27: B leads A, Z is ungated. Z is 330° to 360° wide.</p>	
<p>Code N28: A leads B, Z is 180° wide.</p>		<p>Code N29*: B leads A, Z gated with B-bar. Z is 180° wide.</p>	
<p>Code N33*: A leads B, Z gated with B-bar. Z is 180° wide.</p>		<p>Code N30: B leads A, Z is a negative marker gated with B. Z is 180° wide.</p>	
<p>Code N31: A leads B, Z is a minimum width of 270° (electrical degrees).</p>		<p>Code N32: B leads A. Z has a minimum width of 270°.</p>	

Note: * For RI-10/12/65 encoders, Z is 160° Wide