

Rotary Position Technology

Absolute Encoders, Multiturn

Absolute, Multiturn Type RM-117

SSI



Bearing-Lock



High rotational speed

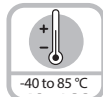

Temperature range
-40 to 85 °C



High IP



High shaft load capacity



Shock/vibration resistant



Reverse polarity protection



Surface protection
Salt spray-tested optional

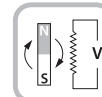

Energy harvesting



Standard option
stainless steel

High Robustness

- Sturdy bearing construction in Bearing-Lock design for particularly high resistance.
- Extra large bearings.
- Mechanically protected shaft seal.
- Protection level IP66, IP67 and IP69k in one device.
- Wide temperature range -40 °C to +85 °C.
- Without gear and without battery, thanks to the Energy Harvesting technology.



Absolute



Application Oriented

- Absolute accuracy $\pm 1^\circ$.
- Repeat accuracy $\pm 0.2^\circ$.
- Short control cycles, clock frequency with SSI up to 2 MHz.
- Max. resolution 38 bit (14 bit ST + 24 bit MT).

Compact

- Can be used where space is tight: overall diameter is 39 mm.

Mechanical Characteristics:

| | |
|--|--|
| Max. speed: | 4000 RPM 2000 RPM (continuous) |
| Starting torque (68 °F 20 °C): | < 1.4 oz - in (0.01 Nm) |
| Shaft load capacity: | |
| Radial: | 18 lbs (80 N) |
| Axial: | 9 lbs (40 N) |
| Weight: | approx. 0.44 lbs (0.2 kgs) |
| Protection acc. to EN 60529: | IP66, IP67, IP69K |
| Working temperature: | -40 to +185 °F (-40 to +85 °C) |
| Materials: | Standard /N72 (stainless steel) |
| Shaft: | stainless steel: V2A (304) V4A (316) |
| Flange: | aluminum V4A (316) |
| Housing: | zinc die-cast V4A (316) |
| Cable: | PUR — |
| Shock resistance acc. to EN 60068-2-27: | 500 g (5000 m/s ²) 4 ms |
| Vibration resistance acc. to EN 60068-2-6: | 30 g (300 m/s ²), 10 - 2000 Hz |

Absolute, Multiturn Type RM-117

SSI

General Electrical Characteristics:

| | |
|---|--|
| Power supply | 10 - 30 VDC |
| Current consumption (no load): | max. 30 mA, |
| Reverse polarity protection at power supply (+V): | yes |
| Short-circuit protected outputs: | yes ¹⁾ |
| e1 compliant acc. to (pending): | EU guideline 2009/19/EC (acc. to EN 55025, ISO 11452 and ISO 7637) |
| UL approval: | file E356899 |
| CE compliant acc. to: | EMC guideline 2014/30/EU RoHS guideline 2011/65/EU |

Interface Characteristics SSI:

| | |
|--|------------------------|
| Output driver: | RS485 transceiver type |
| Permissible load / channel: | max +/- 30 mA |
| Signal high: | typ 3.8 V |
| Signal level low with I _{Load} = 20 mA: | typ 1.3 V |
| Resolution singleturn: | 10 - 14 bit |
| Absolute accuracy ²⁾ : | ±1 ° |
| Repeat accuracy: | ±0.2 ° |
| Number of revolutions (multiturn): | max 24 bit |
| Code: | binary or gray |
| SSI clock rate: | 50 kHz - 2 MHz |
| Data refresh rate: | 2 ms |
| Monoflop time: | ≤ 15 µs |

Note: If the clock cycle starts within the monoflop time a second data transfer begins with the same data. If the clock cycle starts after the monoflop time the cycle begins with the new values. The update rate is dependent on the clock speed, data length and monoflop time.

SET Input:

| | |
|-----------------------------------|--|
| Input characteristics: | active HIGH |
| Input type: | comparator |
| Signal level high: | min. 60% of +V (power supply), max: +V |
| Signal level low: | max. 30% of +V (power supply) |
| Input current: | < 0.5 mA |
| Min. pulse duration (SET): | 10 ms |
| Input delay: | 1 ms |
| New position data readable after: | 1 ms |
| Internal processing time: | 200 ms |

The encoder can be set to zero at any position by means of a HIGH signal on the SET input. Other preset values can be factory-programmed. The SET input has a signal processing time of approx. 1 ms, after which the new position data can be read via SSI or BiSS. Once the SET function has been triggered, the encoder requires an internal processing time of typ. 200 ms; during this time the power supply must not be switched off.

The SET function should be carried out while the encoder is at rest.

If this input is not used, it should be connected to 0 V (Encoder ground GND) in order to avoid interferences.

DIR Input:

Direction input: A HIGH signal switches the direction of rotation from the default cw to ccw. This inverted function can also be factory-programmed.

If this input is not used, it should be connected to 0 V (Encoder ground GND) in order to avoid interferences.

Response time (DIR input) 1 ms

Power-On Delay:

After Power-ON the device requires a time of approx. 150 ms before valid data can be read.

Hot plugging of the encoder should be avoided.

¹⁾ = short circuit protected to 0V or to output when power supply correctly applied.
²⁾ = over the entire temperature range.

| Connection Type: | GND (0 V) | V+ | +Clock | -Clock | +Data | -Data | SET | DIR | PE |
|------------------|-----------|----|--------|--------|-------|-------|-----|-----|--------|
| Cable: | WH | BN | GN | YE | GY | PK | BU | RD | Shield |
| M12 pin: | 1 | 2 | 3 | 4 | 5 | 6 | 7 | 8 | PH |

Wiring Diagrams:

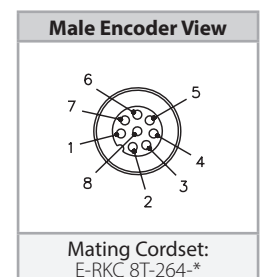

* Length in meters.

Rotary Position Technology

Absolute Encoders, Multiturn

Absolute, Multiturn Type RM-117

SSI

Part Number Key: RM-117 Shaft Version

| A | B | C | | D | E1 | E2 | | F | | G |
|---------|---|---|---|----|-----|-----|---|-------|---|---|
| RM-117S | 6 | C | - | 3C | 10S | 12M | - | H1181 | / | |

| A | Type |
|---------|--|
| RM-117S | Ø 39 mm, Shaft w/ Flat, IP69K Shaft Seal |

| B | Shaft (Ø x L) |
|----|------------------|
| 6 | Ø 6 mm x 12.5 mm |
| 8 | Ø 8 mm x 15 mm |
| 10 | Ø 10 mm x 20 mm |
| A0 | Ø 1/4" x 1/2" |

| C | Flange |
|---|-------------------------|
| C | Ø 42 mm Clamping Flange |

| D | Voltage Supply and Output Type |
|----|--------------------------------|
| 3C | 10 - 30VDC, SSI (Gray Code) |
| 5C | 10 - 30VDC, SSI (Binary Code) |

| E1 | Resolution (singleturn) |
|-----|-------------------------|
| 10S | 10 bit |
| 12S | 12 bit |
| 13S | 13 bit |
| 14S | 14 bit |

| E2 | Resolution (multiturn) |
|-----|------------------------|
| 12M | 12 bit |
| 16M | 16 bit |
| 20M | 20 bit |
| 24M | 24 bit |

| F | Type of Connection |
|-------|-------------------------------------|
| H1181 | Radial 8-pin M12 Eurofast Connector |
| C1M | Radial Cable (1 m PUR) |

| G | Options |
|---------|---|
| (BLANK) | No Options |
| N72 | All Exposed Materials 316SST ¹ |

¹ = only available with shaft '10' and connection 'H1181'

Absolute, Multiturn Type RM-117

SSI

Dimensions: RM-117 Shaft Version

**RM-117 Flange C
 Connection H1181**

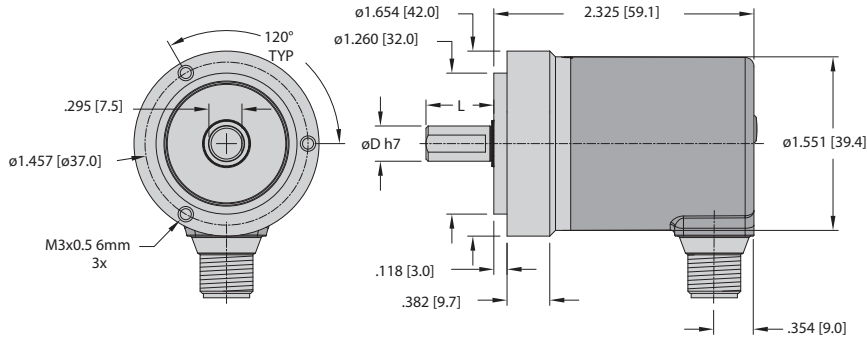

**RM-117 / N72 Flange C
 Connection H1181**

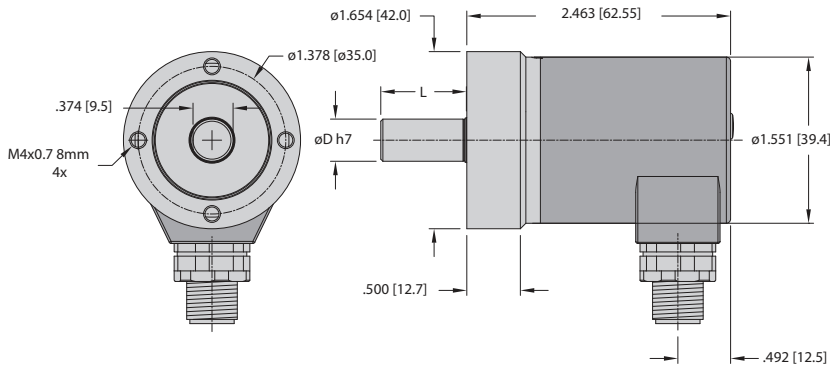

Mounting Advice:

The flanges and shafts of the encoder and drive should not be rigidly coupled together at the same time. We recommend the use of suitable couplings (see page G1, Accessories).