

Absolute, Multiturn Type RM-29 (Shaft) / RM-36 (Blind Hollow Shaft)

CANopen/CANlift

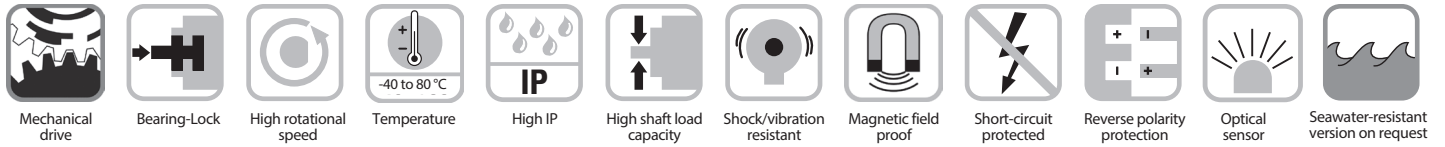

Reliable

- **Increased ability to withstand vibration and installation errors.** Sturdy Bearing-Lock design structure eliminates machine downtime and repairs.
- **Fewer components and connection points increase the operational reliability:** Turck OptoASIC technology with highest integration density (Chip-on-Board).
- Die housing and protection up to IP67: **Remains sealed even when subjected to harsh everyday use.**
- Wide temperature range.

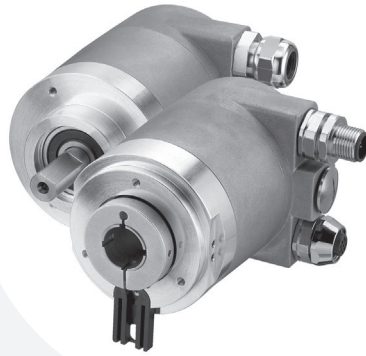

Absolute



CANopen



Fast

- **Real time-servo position detection of several axes:** Extended CAN Sync Mode with realtime position acquisition.
- **Fast data availability, while reducing the load on the bus and the controller:** Intelligent functions like the transmission of speed, acceleration or exiting a working area.

Versatile

- CANopen, CANlift fieldbus with the latest profiles.
- **Connections for every application:** Bus terminal cover with M12 connector or fixed connection with M12, M23 or D-Sub connector. Point-to-point connections also available.
- **Real-time data: Position, speed or working area.** Variable PDO mapping in the memory.
- **Fast, error-free start-up, without setting any switches.** Node address, baud rate and termination can be programmed via the bus.
- Direct mounting of hollow shaft on large diameter standard shafts; up to 15 mm for blind hollow shaft.

Mechanical Characteristics:

Max. speed without shaft sealing (IP65) up to 158 °F (70 °C):	9,000 RPM, continuous 7,000 RPM
Max. speed without shaft sealing (IP65) up to Tmax:	7,000 RPM, continuous 4,000 RPM
Max. speed with shaft sealing (IP67) up to 158 °F (70 °C):	8,000 RPM, continuous 6,000 RPM
Max. speed with shaft sealing (IP67) up to Tmax:	6,000 RPM, continuous 3,000 RPM
Starting torque without shaft seal (IP65):	1.4 oz-in (< 0.01 Nm)
Starting torque with shaft seal (IP67):	4.25 oz-in (< 0.03 Nm)
Moment of inertia:	Shaft version: 0.219 oz-in ² (4.0 x 10 ⁻⁶ kgm ²) Hollow shaft version: 0.41 oz-in ² (7.5 x 10 ⁻⁶ kgm ²)
Radial load capacity of shaft:	18 lbs (80 N)
Axial load capacity of shaft:	9 lbs (40 N)
Weight:	approx. 1.26 lbs (0.57 kg) with bus terminal cover approx. 1.15 lbs (0.52 kg) with fixed connection
Protection acc. to EN 60 529:	Housing: IP67, Shaft: IP65, opt. IP67
Working temperature:	-40 to +176 °F (-40 to +80 °C) ¹⁾
Materials:	Shaft: stainless steel, Flange: aluminum, Housing: die cast zinc, Cable: PVC
Shock resistance acc. to DIN-IEC 68-2-27:	> 250 g (> 2,500 m/s ²), 6 ms
Vibration resistance acc. to DIN-IEC 68-2-6:	> 10 g (> 100 m/s ²), 55-2,000 Hz

¹⁾ Cable versions: -22 to +167 °F (-30 to +75 °C)



- Safe operation in strong magnetic fields
- Special gears with specific toothings

Rotary Position Technology

Absolute Encoders, Multiturn

Absolute, Multiturn Type RM-29 (Shaft) / RM-36 (Blind Hollow Shaft)

CANopen/CANlift

General Electrical Characteristics:

Supply voltage:	10-30 VDC
Current consumption (w/o output load):	Max. 100 mA
Reverse polarity protection:	Yes
RoHS compliant acc. to EU guideline 2011/65/EU	
UL approval:	file E356899

SET Control Button (zero or defined value, option)

Protected against accidental activation, can only be depressed with the tip of a ballpoint pen or similar.

Diagnostic LED (yellow)

LED on with: optical sensor path faulty (code error, LED error), low voltage and over-temperature

Incremental Track Characteristics:

Output driver:	RS422 (TTL-compatible)
Permissible load/channel:	Max. 20 mA
Signal level:	High typ. 3.8 V Low typ. 1.3 V
Short circuit protected:	Yes ¹⁾
Resolution:	2048 ppr

¹⁾ Short circuit to OV or to output, only one channel at a time, supply voltage correctly applied.

Interface Characteristics CANopen/CANlift:

Singleturn resolution (max, scalable):	1-65536 (16 bits), default scale value is set to 8192 (13 bits)
Total resolution:	1-268 435 456 (28 Bit) Default: 25 bit
Code:	Binary
Interface:	CAN High-Speed according ISO 11898, Basic and Full-CAN CAN Specification 2.0 B

Protocol:	CANopen profile DS 406 V3.2 with manufacturer-specific add-on's or CANlift profile DS 417 V1.1
Baud rate:	10-1000 kbits/s (set by DIP switches/software configurable)
Node address:	1-127 (set by rotary switches/software configurable)
Termination switchable:	Set by DIP switches (software configurable)

General Information about CAN/CANlift

The CANopen encoders support the latest CANopen communication profile according to DS 301 V4.02. In addition, device-specific profiles, like the DS 406 V3.2 and DS 417 V1.1 (for lift applications), are available. The following operating modes may be selected: Polled Mode, Cyclic Mode, Sync Mode and a High Resolution Sync Protocol. Moreover, scale factors, preset values, limit switch values and many other additional parameters may be programmed via the CANopen fieldbus. When switching the device on, all parameters, which have been saved on an EEPROM to protect them against power failure, are loaded again.

Position, speed, acceleration and status output values may be combined in a freely variable way as PDO mapping.

Encoders with a connector or a cable connection are available. Models with bus terminal cover and integrated T-shaped coupler allow a particularly easy installation via M12 connectors. The device address is set by means of two hexadecimal rotary switches. Furthermore, another DIP switch allows setting the baud rate and switching on a termination resistor. Three LEDs indicate the operating or fault status of the CANopen fieldbus, as well as the status of an internal diagnostics.

CANopen Communication Profile DS 301 V4.02

The following functionality is integrated: Class C2 Functionality • NMT Slave • Heartbeat Protocol • High Resolution Sync Protocol • Identity Object • Error Behavior Object • Variable PDO Mapping • Self-start programmable (power on to operational) • Three Sending PDO's • Node address, baud rate and CANbus • Programmable termination

CANopen Encoder Profile DS 406 V3.2

The following parameters may be programmed:

- Event mode
- Units for speed selectable (Steps/Sec or RPM)
- Factor for speed calculation (e.g. measuring wheel circumference)
- Integration time for speed value of 1 to 32
- Two work areas with 2 upper and lower limits and the corresponding output states
- Variable PDO mapping for position, speed, acceleration and work area status
- Extended failure management for position sensing with integrated temperature control
- User interface with visual display of bus and failure status – 3 LED's
- Optional – 32 CAM's programmable
- Customer-specific memory – 16 Bytes

CANopen Lift Profile DS 417 V1.1

The following functionality is integrated:

- Car position unit
- Two virtual devices
- One virtual device delivers the position in absolute measuring steps (steps)
- One virtual device delivers the position as an absolute travel information in millimeters
- Lift number programmable
- Independent setting of the node address in relation with the CAN identifier
- Factor for speed calculation (e.g., measuring wheel circumference)
- Integration time for speed value of 1 to 32
- Two work areas with 2 upper and lower limits and the corresponding output states
- Variable PDO mapping for position, speed, acceleration, work area status
- Extended failure management for position sensing with integrated temperature control
- User interface with visual display of bus and failure status – 3 LEDs

Key features:

The object 6003h "Preset" is assigned to an integrated key, accessible from the outside "Watchdog-controlled" device.

Absolute, Multiturn Type RM-29 (Shaft) / RM-36 (Blind Hollow Shaft) CANopen/CANlift

Standard Wiring: Bus Terminal Cover with Terminal Box (Connection TB)

Direction	OUT					IN				
	CAN Ground	CAN_Low (-)	CAN_High (+)	Common (0 V) power supply	+V power supply	Common (0 V) power supply	+V power supply	CAN_Low (-)	CAN_High (+)	CAN Ground
Signal:	CG	CL	CH	0V	+V	0V	+V	CL	CH	CG
Abbrv:	CG	CL	CH	0V	+V	0V	+V	CL	CH	CG

Cable Connection (Connection BC)

Direction	IN				
Signal:	Common (0 V) power supply	+V power supply	CAN_Low (-)	CAN_High (+)	CAN Ground
Abbrv:	0V	+V	CL	CH	CG
Cable:	WH	BN	YE	GN	GY

M23 Connector or M12 Connector or D-Sub 9 (Connection B1M23) (Connection B1M12) (Connection B1D9)

Direction	IN					Pinout
Signal:	Common (0 V) power supply	+V power supply	CAN_Low (-)	CAN_High (+)	CAN Ground	
Abbrv:	0V	+V	CL	CH	CG	
M23 Multifast:	10	12	2	7	3	A
M12 Eurofast:	3	2	5	4	1	C
D-Sub 9:	6	9	2	7	3	-

Bus Terminal Cover with 2 - M12, 2 - M12, 2 - M23 (Connection R2M12) (Connection B2M12) (Connection B2M23)

Direction	OUT					Pinout	IN					Pinout
	CAN Ground	CAN_Low (-)	CAN_High (+)	0V power supply	+V power supply		0V power supply	+V power supply	CAN_Low (-)	CAN_High (+)	CAN Ground	
Signal:	CG	CL	CH	0V	+V		0V	+V	CL	CH	CG	
Abbrv:	CG	CL	CH	0V	+V	A	0V	+V	CL	CH	CG	A
M23 Multifast:	3	2	7	10	12	A	10	12	2	7	3	A
M12 Eurofast:	1	5	4	3	2	B	3	2	5	4	1	C

Terminal Assignment Incremental Track (Connection R3M12 = Connection R2M12 plus 1-M12 for Incremental output)

Signal:	A	Ā	B	B	0V	Pinout
Pin:	1	2	3	4	5	D

Wiring Diagrams:

A	B	C	D
Male Encoder View	Female Encoder View	Male Encoder View	Male Encoder View
<p>CCW</p> <p>Bus In and Out M23 Multifast Pinout</p>	<p>Bus Out M12 Eurofast Pinout</p>	<p>Bus In M12 Eurofast Pinout</p>	<p>Incremental Track M12 Eurofast Pinout</p>
Mating Cordset: ¹⁾ Consult factory	Mating Cordset: ¹⁾ RSC 572-*M/S3118	Mating Cordset: ¹⁾ RKC 572-*M/S3117	Mating Cordset: ¹⁾ WASW 4.5T-*S618

¹⁾ See Connectivity section H for corresponding cable color code.
* Length in meters. Available in 0.1 meter increments ≥0.2 meters.

Rotary Position Technology

Absolute Encoders, Multiturn

Absolute, Multiturn Type RM-29 (Shaft) / RM-36 (Blind Hollow Shaft) CANopen/CANlift

Part Number Key: RM-29 Shaft Version

A	B	C		D		E		F
RM-29S	6	C	-	9D28B	-	B1M12	/	N46

A	Type
RM-29S	Ø 58 mm, Shaft, IP67 Shaft Seal
RM-29T	Ø 58 mm, Shaft, IP65 Shaft Seal

B	Shaft (Ø x L)
6	Ø 6 mm x 10 mm
10	Ø 10 mm x 20 mm
A0	Ø 1/4" x 7/8"
A1	Ø 3/8" x 7/8"

C	Flange
C	Ø 58 mm Clamping Flange
S	Ø 58 mm Servo Flange
R	2.5" Square Flange

D	Voltage Supply and Output Type
9D28B	10-30 VDC, CANopen DS 301 V4.02
9G28B	10-30 VDC, CANopen DS 301 V4.02 w/ 2048PPR Incremental Track (TTL-Compatible) ¹⁾

¹⁾ Only available with connector R3M12.

E	Type of Connection
B1M12	Radial 1 x M12 Eurofast Connector w/o Bus Terminal Cover
R2M12	Radial 2 x M12 Eurofast Connectors w/ Bus Terminal Cover
R3M12	Radial 3 x M12 Eurofast Connectors w/ Bus Terminal Cover ²⁾
B1M23	Radial 1 x M23 Multifast Connector w/o Bus Terminal Cover
B2M23	Radial 2 x M23 Multifast Connectors w/o Bus Terminal Cover
B1D9	Radial 1 x 9-pin D-SUB Connector w/o Bus Terminal Cover
BC	Radial Cable (2 m PVC) w/o Bus Terminal Cover
RC	Radial Cable Gland w/ Bus Terminal Cover

²⁾ Only valid with Incremental track output option 9G28B

F	Options ³⁾
N46	SET Button
N47	CANlift DS 417 V1.01

³⁾ CAN parameters can be factory-preset

Part Number Key: RM-36 Blind Hollow Shaft Version

A	B	C		D		E		F
RM-36B	10	T	-	9D28B	-	B1M12	/	N46

A	Type
RM-36B	Ø 58 mm, Blind Hollow Shaft, IP67 Shaft Seal
RM-36C	Ø 58 mm, Blind Hollow Shaft, IP65 Shaft Seal

B	Bore (30 mm Insertion Depth)
10	Ø 10 mm
12	Ø 12 mm
14	Ø 14 mm
15	Ø 15 mm
A1	Ø 3/8"
A3	Ø 1/2"

C	Flange
T	Ø 50 mm Flange w/ Torque Stop
E	Ø 63 mm Flange w/ Slotted Flex Mount
E1	Ø 65 mm Flange w/ Flex Mount

D	Voltage Supply and Output Type
9D28B	10-30 VDC, CANopen DS 301 V4.02
9G28B	10-30 VDC, CANopen DS 301 V4.02 w/ 2048PPR Incremental Track (TTL-Compatible) ¹⁾

¹⁾ Only available with connector R3M12.

E	Type of Connection
B1M12	Radial 1 x M12 Eurofast Connector w/o Bus Terminal Cover
R2M12	Radial 2 x M12 Eurofast Connectors w/ Bus Terminal Cover
R3M12	Radial 3 x M12 Eurofast Connectors w/ Bus Terminal Cover ²⁾
B1M23	Radial 1 x M23 Multifast Connector w/o Bus Terminal Cover
B2M23	Radial 2 x M23 Multifast Connectors w/o Bus Terminal Cover
B1D9	Radial 1 x 9-pin D-SUB Connector w/o Bus Terminal Cover
BC	Radial Cable (2 m PVC) w/o Bus Terminal Cover
RC	Radial Cable Gland w/ Bus Terminal Cover

²⁾ Only valid with Incremental track output option 9G28B

F	Options ³⁾
N46	SET Button
N47	CANlift DS 417 V1.01

³⁾ CAN parameters can be factory-preset

Accessories:

- See page H1, Connectivity, for cables and connectors
- See page G1, Accessories, for mounting attachments and couplings



Absolute, Multiturn Type RM-29 (Shaft) / RM-36 (Blind Hollow Shaft)

CANopen/CANlift

Dimensions: RM-29 Shaft Version

**RM-29 Flange R
 Connection RC**

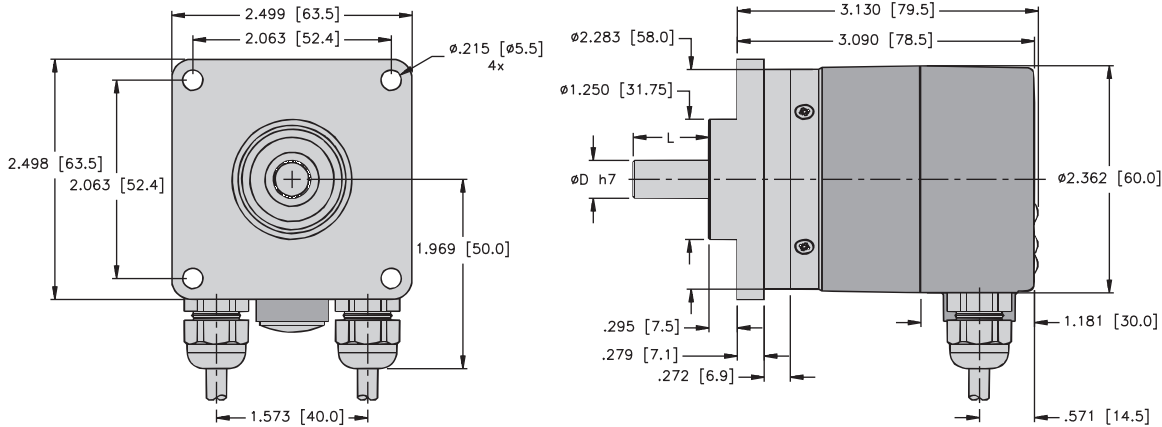

**RM-29 Flange C
 Connection R2M12**

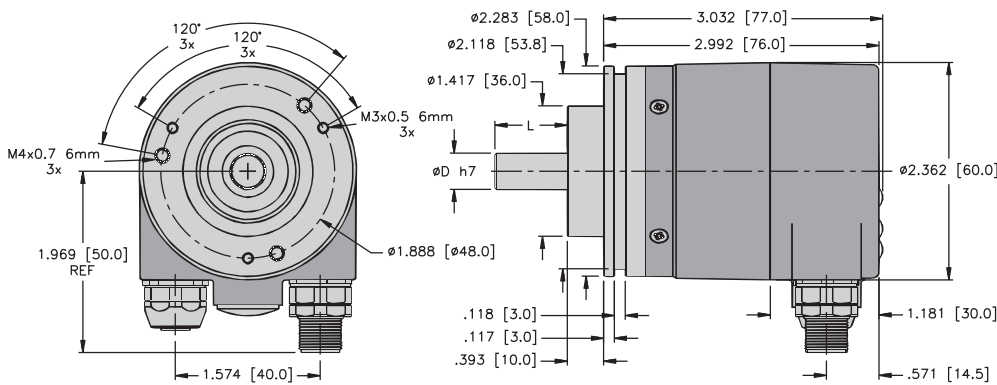

**RM-29 Flange C
 Connection BC**

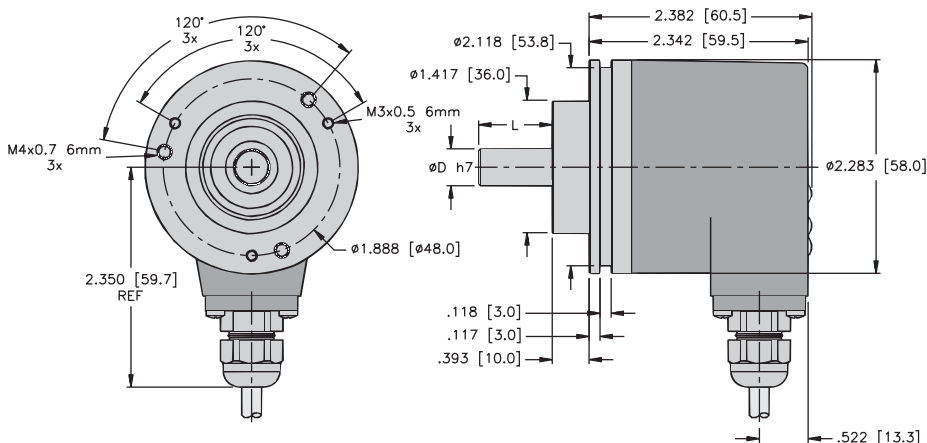

Rotary Position Technology

Absolute Encoders, Multiturn

Absolute, Multiturn Type RM-29 (Shaft) / RM-36 (Blind Hollow Shaft)

CANopen/CANlift

Dimensions: RM-29 Shaft Version

**RM-29 Flange C
Connection B1M12**

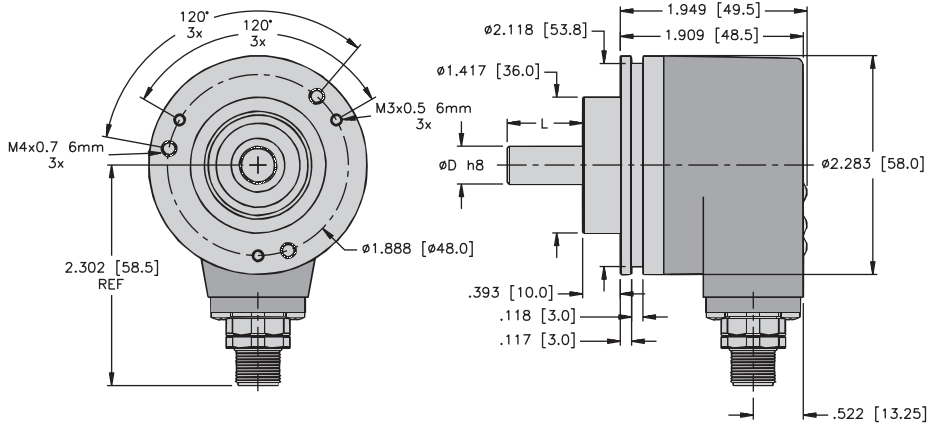

**RM-29 Flange S
Connection B2M12**

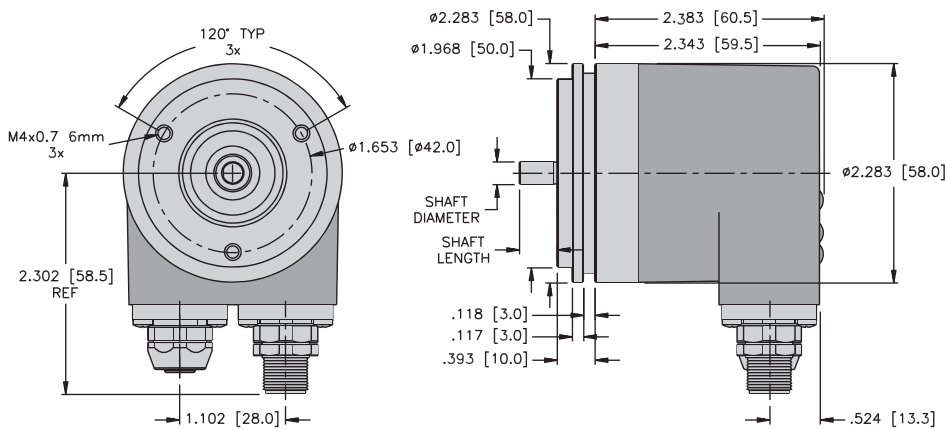

Sendix Absolute, Multiturn Type RM-29 (Shaft) / RM-36 (Blind Hollow Shaft)

CANopen/CANlift

Dimensions: RM-29 Shaft Version

**RM-29 Flange R
 Connection B2M23**

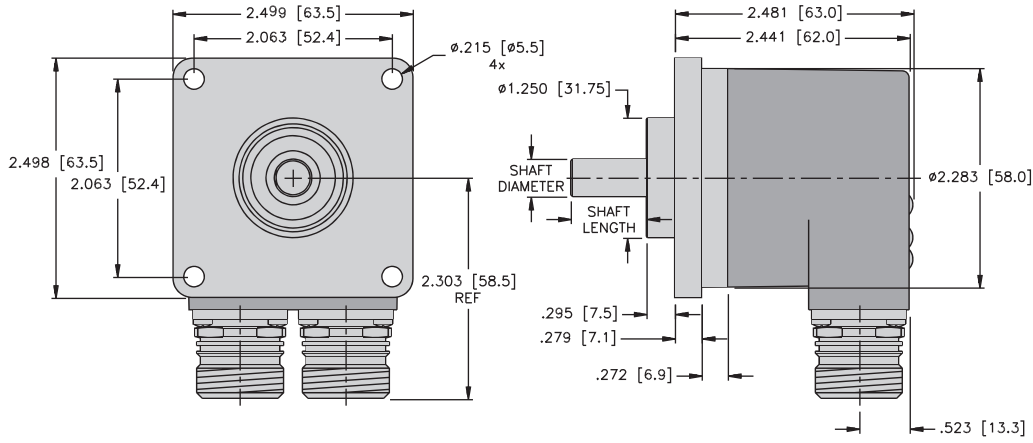

**RM-29 Flange S
 Connection B1D9**

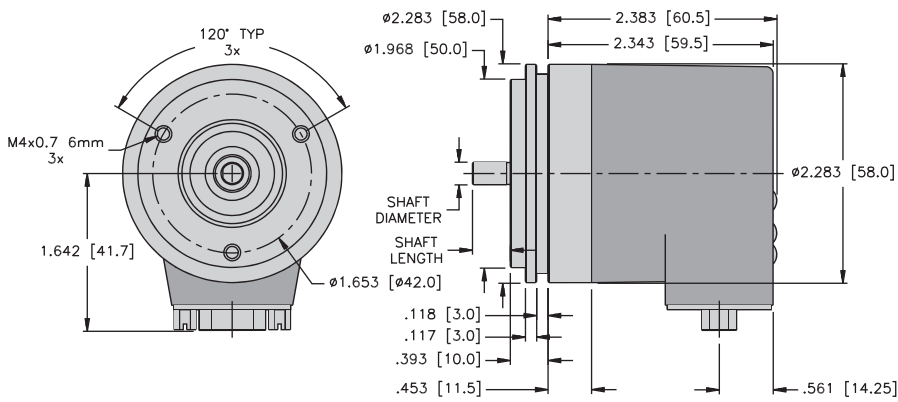

Absolute Encoders

Absolute, Multiturn Type RM-29 (Shaft) / RM-36 (Blind Hollow Shaft) CANopen/CANlift

Dimensions: RM-36 Blind Hollow Shaft Version

**RM-36 Flange E1
 Connection BC**

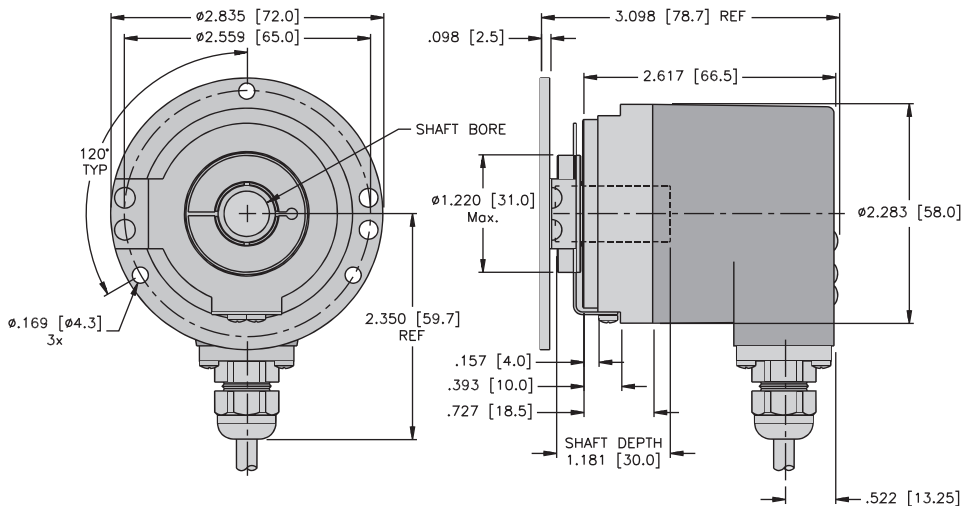

**RM-36 Flange E
 Connection B1M12**

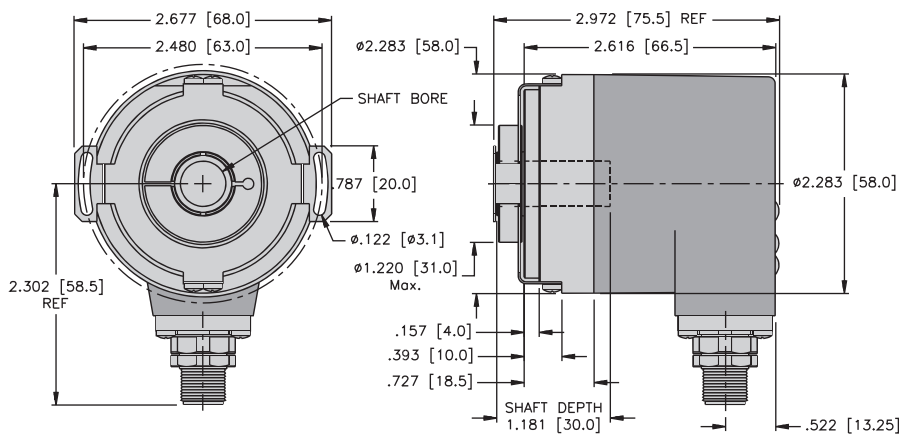

**RM-36 Flange T
 Connection B2M12**

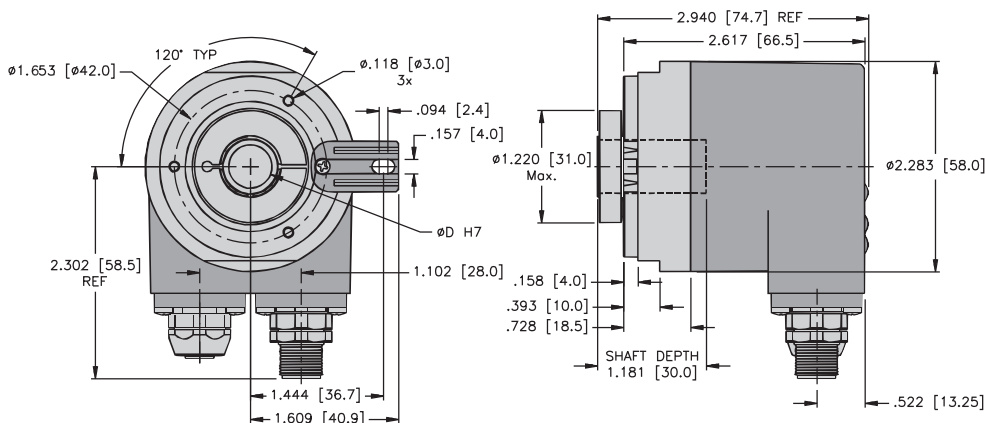

Absolute Encoders

Dimensions: RM-36 Blind Hollow Shaft Version

RM-36 Flange T Connection B1M23

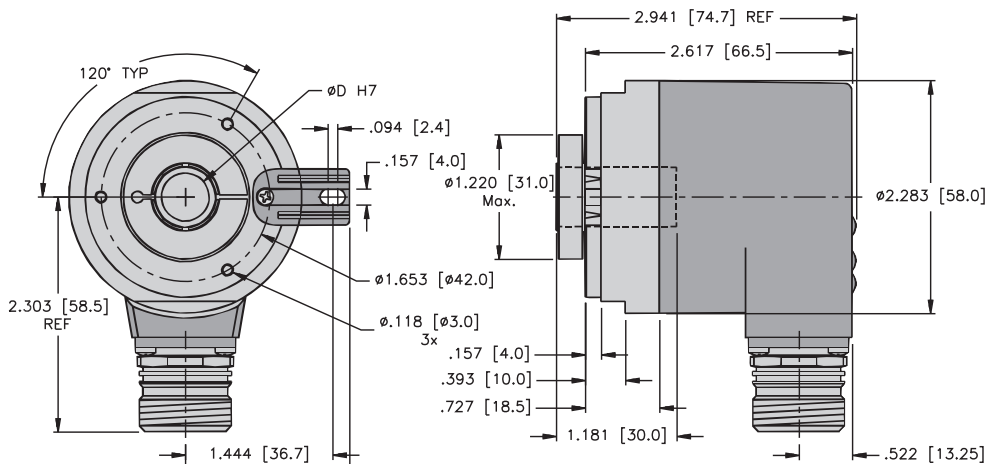

RM-36 Flange E1 Connection B2M23

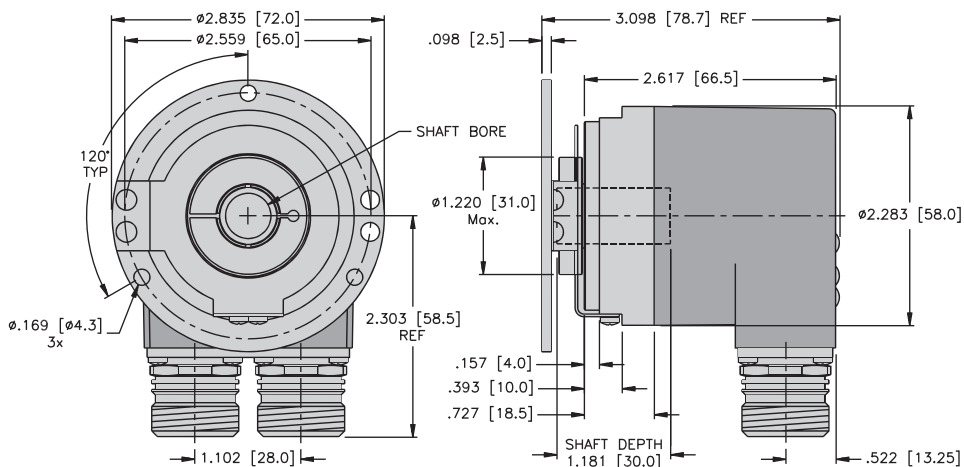

RM-36 Flange T Connection B1D9

