

Rotary Position Technology

Absolute Encoders, Singleturn

Absolute, Singleturn Encoder Type RS-06 (Shaft) / RS-07 (Blind Hollow Shaft)

Analog



Bearing Lock



High rotational speed

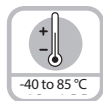

Temperature



High IP



High shaft load capacity



Shock/vibration resistant



Short-circuit protected



Reverse polarity protection

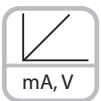

Output

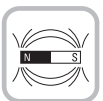

Magnetic sensor



Seawater-resistant version on request

Rugged

- Non-contact measuring system: **Ensures long service life and the reliability of the application.**
- **Stays sealed even when subjected to harsh everyday use.** Solid die-cast housing with up to IP69K protection **offers security against failures in the field.**
- Wide temperature range of -40 to +185 °F (-40 to +85 °C).
- **Increased ability to withstand vibration and installation errors.** High shock (> 500 g) and vibration resistance (> 30 g) **eliminates machine downtime and repairs.**



Absolute



Compact

- **Can be used where space is tight:** Overall diameter of only 36 mm.
- **Shaft version can be mounted on a tight radius:** fixing holes on Ø 26 mm.
- **Hollow shaft version is ideal for large shafts:** blind hollow shaft up to 10 mm.

Versatile

- **Interface of 4-20 mA, 0-10 V:** One size available for different applications.
- **Measuring range of 45°, 90°, 180° and 360°.**
- **Easy diagnosis in case of fault condition:** Error indication via red LED (only current output).
- **Hollow shaft version may be fixed individually:** Torque stop and flex coupling available.
- **May be used in outdoor applications with large fluctuations in temperature:** Resistant against humidity and condensation.

Mechanical Characteristics:

Max. speed:	6,000 RPM
Starting torque:	< 8.5 oz-in (< 0.06 Nm)
Radial load capacity of shaft:	9.0 lbs (40 N)
Axial load capacity of shaft:	4.5 lbs (20 N)
Weight:	approx. 0.44 lbs (0.2 kg)
Protection acc. to EN 60 529 / DIN 40050-9:	IP67 / IP69K
Working temperature range:	-40 to +185 °F (-40 to +85 °C)
Materials:	Shaft: stainless steel, Flange: aluminium, Housing: die cast zinc, Cable: PUR
Shock resistance acc. to EN 60068-2-27:	500 g (5,000 m/s ²), 6 ms
Vibration resistance acc. to EN 60068-2-6:	30 g (300 m/s ²), 10-2,000 Hz
Permanent shock resistance acc. to EN 60068-2-29:	100 g (1,000 m/s ²), 2 ms
Vibration (broad-band random) to EN 60068-2-64:	5-2500 Hz, 10 g (100 m/s ²) - rms

All-round protection:

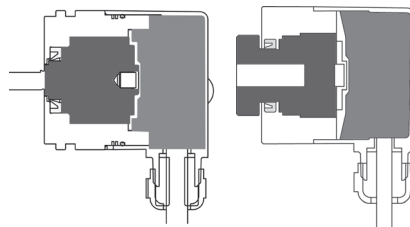

Bearing-Lock:

IP69K protection on the flange side, robust bearing assemblies with interlocking bearings, mechanically protected shaft seal.

Protected Sensor:

Fully encapsulated electronics, separate mechanical bearing assembly.

Absolute, Singleturn Encoder Type RS-06 (Shaft) / RS-07 (Blind Hollow Shaft) Analog

Electrical Characteristics Current Interface 4-20 mA:

Sensor:	
Supply voltage:	10-30 VDC
Current consumption (without output load):	max. 38 mA
Reverse polarity protection at power supply (+V):	Yes
Measuring range:	45°, 90°, 180° or 360°
Resolution/Code:	12 bit
Linearity 77 °F (25 °C):	< 1° (360° measurement range)
Repeat accuracy 77 °F (25 °C):	< 0.1° (360° measurement range)
Status LED:	Red: sensor break detection, input too high Green: reference point (CW: 0° to 1°) (CCW: 0° to -1°)

4-20 mA Current Loop:

Output load:	max. 200 ohms at 10 VDC max. 900 ohms at 24 VDC
Setting time:	1 ms ($R_{load} = 400 \text{ Ohm}$, 77 °F (25 °C))
Short-circuit protected outputs: when the supply voltage is correctly applied, then output to output is short-circuit protected, but not output to 0 V or to +V.	
Supply voltage and sensor output signal are not galvanically isolated.	

Electrical Characteristics Voltage Interface

Sensor:	
Supply voltage:	0-5 V, 10-30 VDC 0-10 V, 15-30 VDC
Current consumption (without output load):	max. 35 mA
Reverse polarity protection at power supply (+V):	Yes
Measuring range:	45°, 90°, 180° or 360°
Resolution/Code:	12 bit
Linearity 77 °F (25 °C):	< 1° (360° measurement range)
Repeat accuracy:	< 0.1° (360° measurement range)

Voltage Output:

Current output:	max. 10 mA
Setting time:	< 1 ms ($R_{load} \geq 1 \text{ KOhm}$, 77 °F (25 °C))
Supply voltage and sensor output signal are not galvanically isolated.	
Short-circuit protected outputs: when the supply voltage is correctly applied, then output to output is short-circuit protected, but not output to 0 V or to +V.	
Status LED	Green: reference point display turns on at cw: between 0° and 1° at ccw: between 0° and -1°

General Electrical Characteristics:

RoHS compliant:	acc. to EU guideline 2011/65/EU
-----------------	---------------------------------

Standard Wiring:

Connection Type:	Common (0 V)	+V	+I	-I
Cable:	WH	BN	GN	YE
M12 Eurofast:	3	2	4	5

Wiring Diagram:

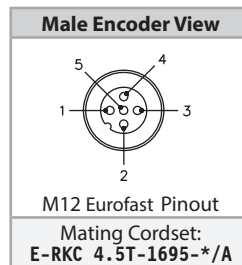

* Length in meters.

Rotary Position Technology

Absolute Encoders, Singleturn

Absolute, Singleturn Encoder Type RS-06 (Shaft) / RS-07 (Blind Hollow Shaft)

Analog

Note: Encoders must be ordered with a clockwise or counterclockwise profile. This determines whether the analog output increases or decreases in the given direction.

Example (Output Signal Profile):

Measuring range 45° / 90° / 180° / 360°

Clockwise (CW) Version

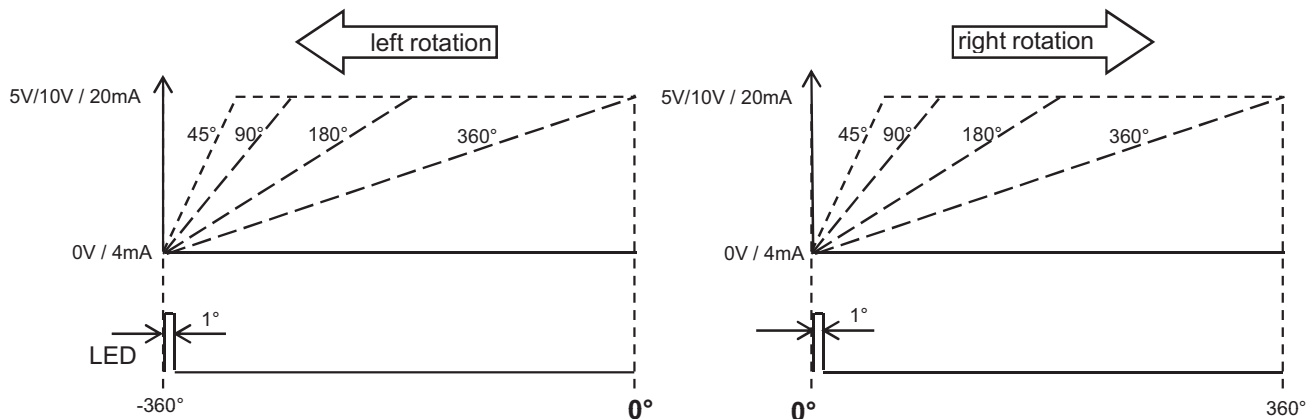

Example (Output Signal Profile):

Measuring range 45° / 90° / 180° / 360°

Counterclockwise (CCW) Version

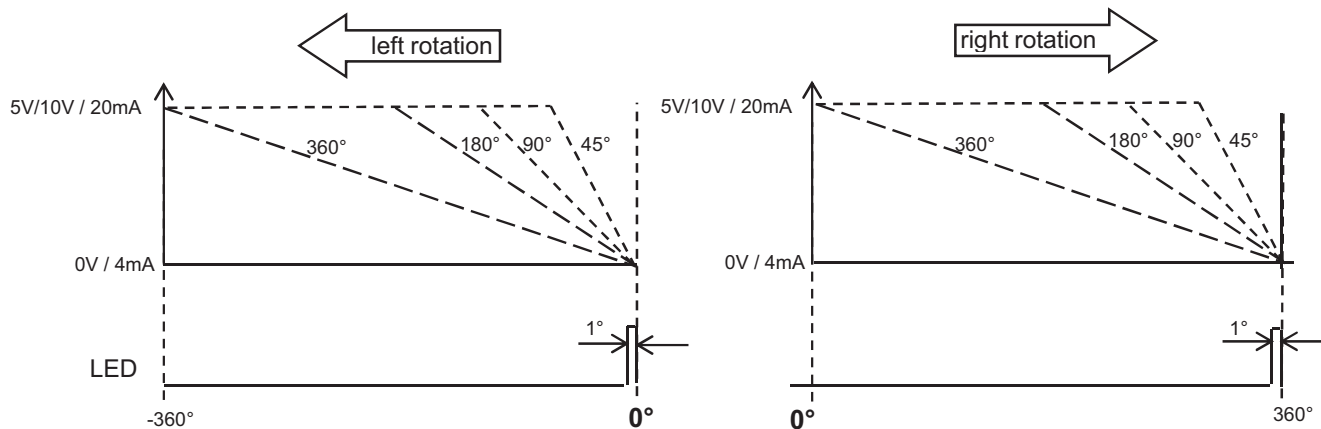

Absolute, Singleturn Encoder Type RS-06 (Shaft) / RS-07 (Blind Hollow Shaft) Analog

Part Number Key: RS-06 Shaft Version

A	B	C		D	E		F		G
RS-06P	6	S	-	7A	AL	-	H1151	/	N0

A	Type
RS-06P	Ø 36 mm, Shaft, IP69K Shaft Seal
RS-06S	Ø 36 mm, Shaft, IP67 Shaft Seal

B	Shaft (Ø x L)
6	Ø 6 mm x 12.5 mm
8	Ø 8 mm x 12.5 mm
A0	Ø 1/4" x 12.5 mm

C	Flange
S	Servo Flange

D	Voltage Supply and Output Type
7A	10-30 VDC, 4-20 mA
8B	15-30 VDC, 0-10 V
BA	10-30 VDC, 0-5 V

E	Direction
AL	Count Direction CCW*
AR	Count Direction CW*

F	Type of Connection
H1151	Radial 5-pin M12 Eurofast® Connector
H1451	Axial 5-pin M12 Eurofast Connector
C1M	Radial Cable (1 m PUR)
CA1M	Axial Cable (1 m PUR)

G	Measurement Range
N0	1 x 360°
N4	1 x 180°
N3	1 x 90°
N1	1 x 45°

*cw = increasing code values when shaft turning clockwise (cw).
Top view on shaft.

Part Number Key: RS-07 Blind Hollow Shaft Version

A	B	C		D	E		F		G
RS-07B	6	E	-	7A	AL	-	H1151	/	N0

A	Type
RS-07B	Ø 36 mm, Blind Hollow Shaft, IP69K Shaft Seal
RS-07C	Ø 36 mm, Blind Hollow Shaft, IP67 Shaft Seal

B	Bore (18 mm Insertion Depth)
6	Ø 6 mm
8	Ø 8 mm
10	Ø 10 mm
A0	Ø 1/4"

C	Flange
E	Ø 46 mm Flange w/ Slotted Flex Mount
T	Flange w/ Long Torque Stop

D	Voltage Supply and Output Type
7A	10-30 VDC, 4-20 mA
8B	15-30 VDC, 0-10 V
BA	10-30 VDC, 0-5 V

E	Direction
AL	Count Direction CCW*
AR	Count Direction CW*

F	Type of Connection
H1151	Radial 5-pin M12 Eurofast Connector
H1451	Axial 5-pin M12 Eurofast Connector
C1M	Radial Cable (1 m PUR)
CA1M	Axial Cable (1 m PUR)

G	Measurement Range
N0	1 x 360°
N4	1 x 180°
N3	1 x 90°
N1	1 x 45°

*cw = increasing code values when shaft turning clockwise (cw).
Top view on shaft.

Accessories:

- See page H1, Connectivity, for cables and connectors
- See page G1, Accessories, for mounting attachments and couplings

Rotary Position Technology

Absolute Encoders, Singleturn

Absolute, Singleturn Encoder Type RS-06 (Shaft) / RS-07 (Blind Hollow Shaft) Analog

Dimensions: RS-06 Shaft Version

RS-06 Flange S Connection C1M & CA1M

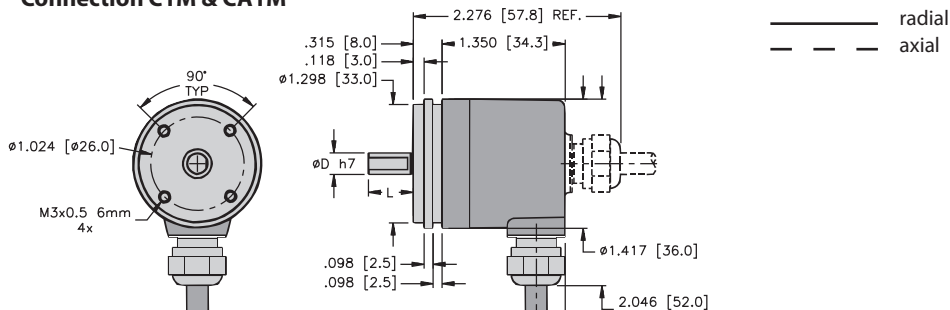

RS-06 Flange S Connection H1151 & H1451

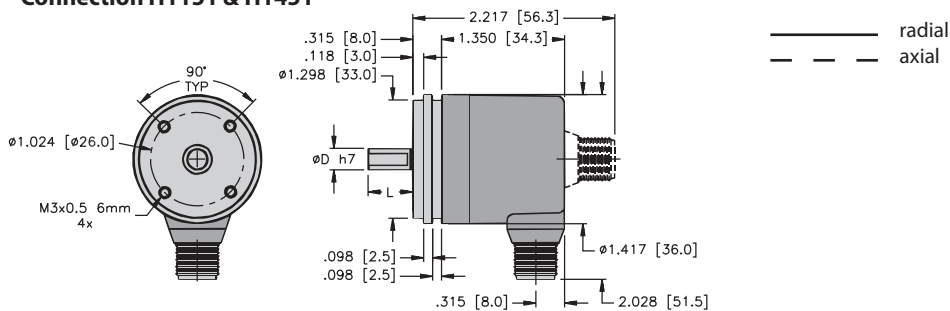

Mounting Advice:

The flanges and shafts of the encoder and drive should not be rigidly coupled together at the same time. We recommend the use of suitable couplings (see page G1, Accessories).

Dimensions: RS-07 Blind Hollow Shaft Version

RS-07 Flange T Connection C1M & CA1M

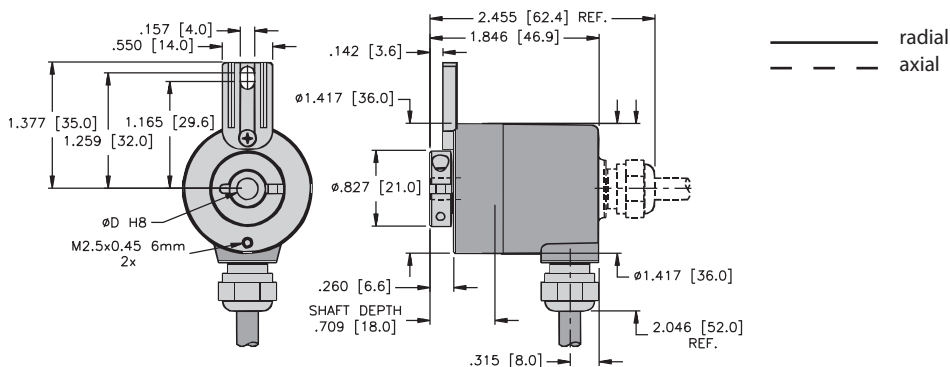

RS-07 Flange E Connection H1151 & H1451

