

How To Use Die Protection for Metal Stamping Operations

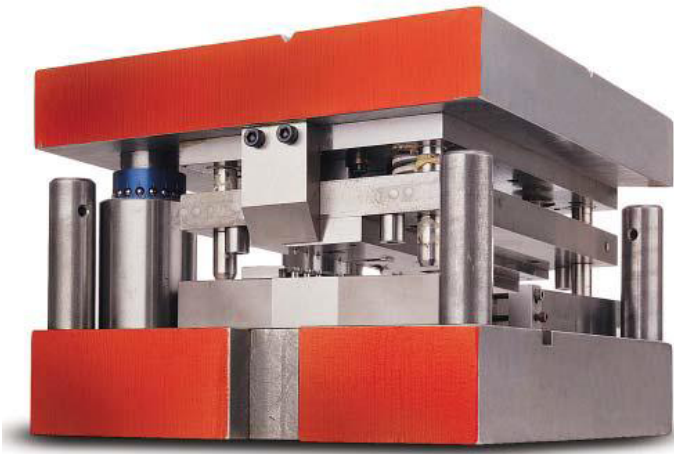

HOW TO





In most industries, the need to improve the efficiency of processes is an imperative part of product manufacturing. This is becoming increasingly important in metal stamping facilities throughout the world, as competition necessitates that products be produced at a much faster rate and at a greater level of conformity.

The number one reason for unexpected downtime or nonconforming parts in metal stamping applications is die crashes. Eliminating die crashes helps control repair processes and improves press time and production scheduling. A die that has been repaired after a crash is also unlikely to produce the same quality product that it did previously. The best way to protect a die from damage is to make sure that nothing is physically out of place during a press cycle. In order to do this, a system of sensors should be mounted in the tooling, encoders should be connected to crankshafts, and the press must be equipped with a controller to interpret the signals from these devices.

Sensors verify processes and reduce the potential for damaging the die by detecting speed, accuracy, target orientation and position, including part ejection and hole placement. It is critical to protect die applications because of the speed of the stamping machine. Some stamping applications, like those for small electronic components, are up to 1,400 to 1,500 strokes per minute, while others, like those for large automotive frames or panels, are

much slower at approximately 30 strokes per minute. At this rate, it is pertinent to ensure proper sensor placement and function. Often in progressive dies sensors are placed at multiple locations within the tool/die for critical point detection, such as bends, short-feed, long-feed, slugs and “missed hits”. There are also other types of dies used in stamping that have specific requirements based on their function, for instance, transfer dies where sensors are incorporated into the grippers to detect that panels are in place before they are transferred to the next station. Using sensors in these environments can reduce downtime and lost production, as well as associated maintenance costs and inadvertently shipping bad parts.

Proximity sensors function by emitting a high-frequency electromagnetic field that interacts with a target. When a metal object (target) enters the high-frequency field, eddy currents are induced on the surface of the target and the sensor is affected by these currents. Proximity sensors may be used in many places and for many functions within the die. This is dependent on the complexity and sophistication of the die, as well as the environmental conditions the sensor will be subject to; for example, the material being sensed, the size of the target, the physical conditions near the die (weld fields, extreme heat/cold, RFI, etc.) and the electrical equipment the sensor will be connected to (relays, PLCs, press controls, etc.).

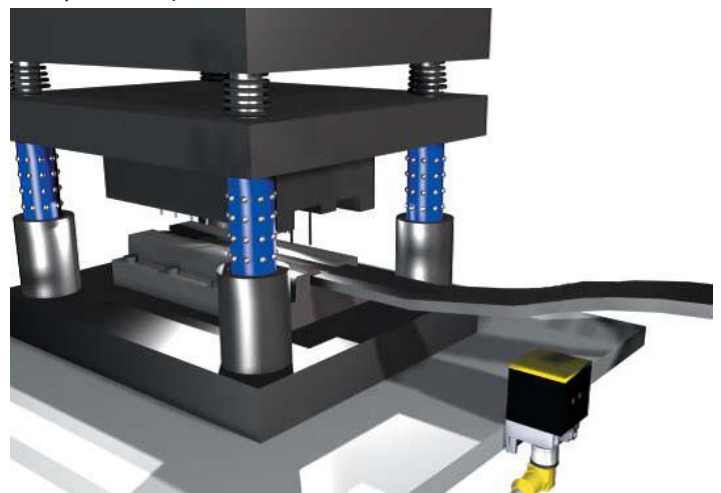

The first thing to determine when incorporating sensors in a die protection application is the location and type of sensors needed to prevent damage. As previously mentioned, sensors can be used to make sure the material has moved forward in the application, to determine that the product has been ejected from the press or to verify that the cams are in the correct position. There are a number of different types of sensors that can be used to achieve these results: Some are contact sensors (mechanical sensors that must be physically touched in order for the output to activate), while others are non-contact (electrical sensors that use magnetic fields, light or sound waves to determine position). Mechanical sensors are less expensive, but they are also subject to tremendous wear which will eventually lead to sensor failure. Electrical sensors that do not require contact are more expensive, but they have a much longer lifetime. A non-contact sensor usually fails due to physical contact rather than everyday wear and tear.

Proximity sensors offer many advantages over contact sensors in stamping applications, in that they are solid state with no moving parts and are impervious to oil, coolant or other liquids/lubricants permeating the sensor. Noncontact devices are also better able to withstand physical damage. Proximity sensors have numerous housing styles that can be integrated in dies, such as miniature, rectangular, low profile and ring sensors. For instance, “flat pack” proximity sensors can be embedded in the die to monitor the stripper plate to determine if slugs have been pulled into the die. A cylindrical proximity sensor can be placed in a spring loaded lifter to detect whether the material has fed properly into position before the die closes.

The graphics show how a proximity sensor is used to detect slugs in the die. The sensor is programmed to measure the position of the die (figure 1). If slugs are deposited after the die stroke (figure 2), the sensor will detect the difference in position.



Figure 1

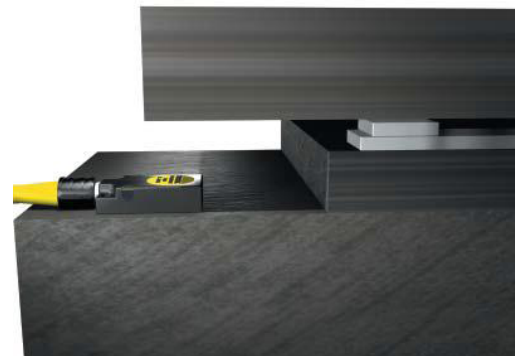

Figure 2

Photoelectric sensors are another type of non-contact sensor that use light (visible or infrared) to determine position or part ejection. These sensors include an emitter that sends out light, and a receiver that measures the amount of light that returns to the sensor. The three basic types of photoelectric sensors are through beam, diffuse reflective and retro reflective. Through beam sensors usually consist of two separate housings for the emitter and receiver. When an object breaks the beam of light a signal is sent to the controller. Similarly, diffuse reflective and retro reflective sensors also send a signal to the controller, however a diffuse reflective sensor sends the signal when the light is reflected off of the part being sensed, while a retro reflective sensor sends a signal when the part interrupts the light being reflected back to the sensor via a reflector (much like those used on bicycles). Photoelectric sensors are also solid state devices with no moving parts and offer much longer sensing ranges than typical proximity



sensors, though they are much more susceptible to fail in dirty environments when oil, dust or other materials block the light to or from the sensor.

No matter what type of sensor is used, the signals that are created must be sent back to a controller so it can take the appropriate action to protect the die. This is accomplished via wires and cables. Some sensors have cable or wires running out of the sensors that can be directly wired to the controller, while other sensors have connectors that allow the customer quick wiring via a cable device known as a cordset. Cordsets are then connected to a central junction box where the signal is routed to the controller via a “home run” cordset. These cordsets and junction boxes are available in a variety of styles (field wired, factory molded or a combination thereof) that are designed to work in harsh manufacturing environments, although in many cases these components need to be further protected from scrap metal, fork lifts or other hazards. Some companies machine channels into the die shoe to protect the cable from damage, while others take it a step further and fill these channels with silicon rubber sealants or use conduit in the channel around the cable or wire.

One of the most difficult problems to overcome in any die protection application is protecting the components

from the environment in which they must function. In a typical stamping application, oils, coolants and other liquids/lubricants are often present that can wreak havoc with the components. Manufacturers of these devices have addressed this problem by making components out of higher grade materials that are less affected by these substances, and therefore classified with an “IP” rating. IP ratings were established by The International Electrotechnical Commission (IEC) to rate the degree to which the enclosures of electrical components are sealed against the intrusion of foreign bodies such as dust and moisture. This classification system implies various degrees of ingress protection, and is indicated by the letters IP followed by two digits. Ingress protection ratings were established to create uniform performance requirements for electronic enclosures intended for specific environments. Some sensors are designed for different levels of IP protection, making them more suitable for the harsh environments that often accompany die protection applications. Alternative housing, connector and front cap materials are some of the aspects manufacturers alter to make sensors more resistant. In general, as you invest more resources and components into your die protection system, the likelihood of failure or downtime is exponentially reduced.



Companies that enlist sensor specialists to ensure the best sensor is used per application will attain optimal performance from their operations. Only a small percentage of stamping companies use sensor specialists. Manufacturers demanding zero part defect or that implement just in time manufacturing will find that incorporating sensors into dies will help to decrease downtime, part defects and associated maintenance costs.