

| MALE END VIEW | FEMALE END VIEW | WIRING DIAGRAM | SPECIFICATIONS | |
|--|--|---|--------------------------------|----------------------------------|
|  |  |  | CONTACT CARRIER MATERIAL/COLOR | TPU/YELLOW |
| | | | MOLDED HEAD MATERIAL/COLOR | TPU/YELLOW |
| | | | CONTACT MATERIAL/PLATING | BRASS/GOLD |
| | | | COUPLING NUT MATERIAL/PLATING | BRASS/NICKEL |
| | | | RATED CURRENT [A] | 9.0 A |
| | | | RATED VOLTAGE [V] | 250 V |
| | | | TEMPERATURE RATING | -40°C TO +80°C (-40°F TO +176°F) |
| | | | PROTECTION CLASS | MEETS NEMA 1,3,4,6P AND IEC IP67 |

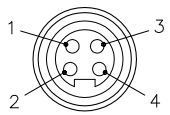
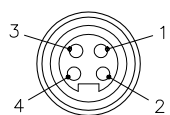
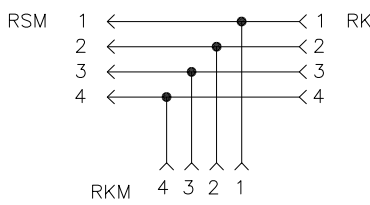
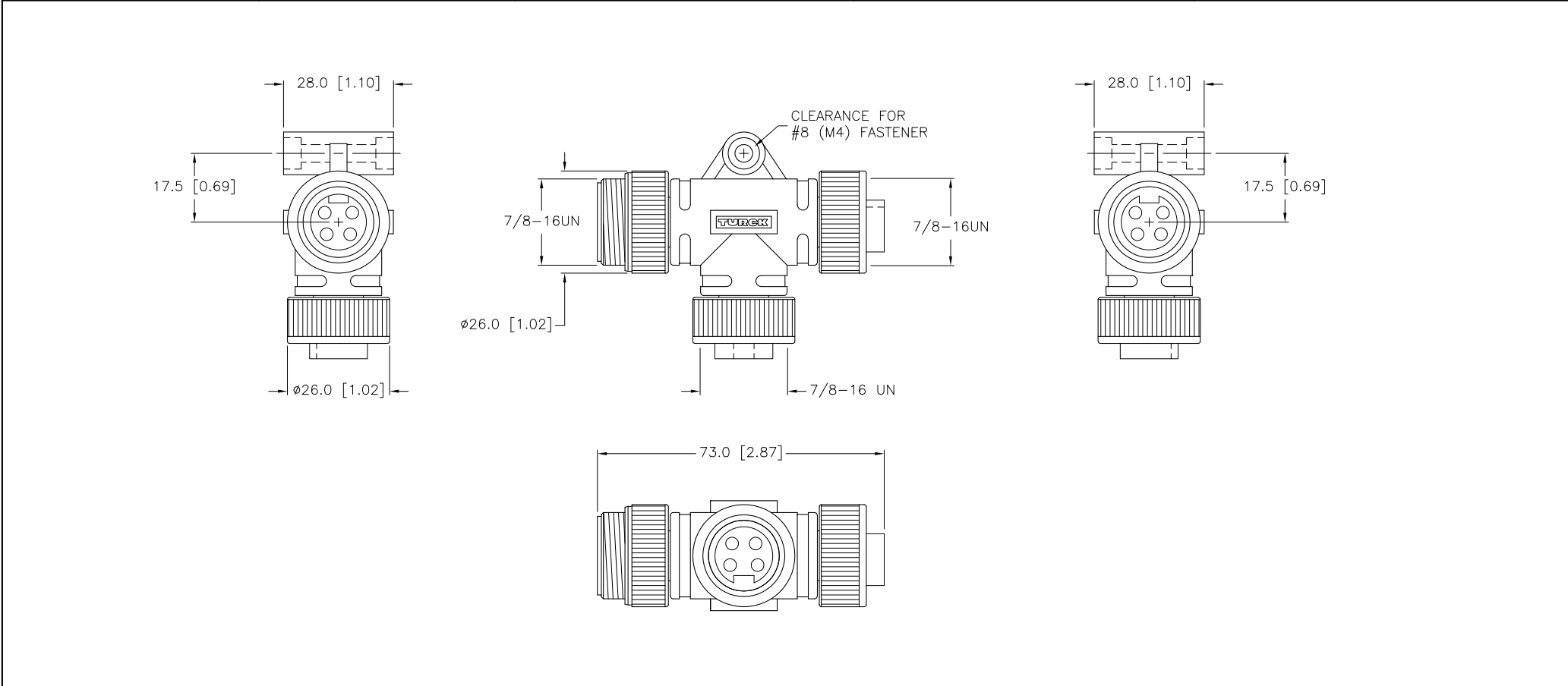
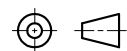

SOURCE DRAWING - FOR REFERENCE ONLY

| | | | | | |
|---|---|---|---|---|----------|
| RELATED DOCUMENTS 1. 2. 3. 4. | | 3RD ANGLE PROJECTION  | THIS DRAWING IS PROPERTY OF TURCK INC. USE OF THIS DOCUMENT WITHOUT WRITTEN PERMISSION IS PROHIBITED. | 3000 CAMPUS DRIVE MINNEAPOLIS, MN 55441 1-800-544-7769 (763) 553-7300 (763) 553-0708 fax turck.com | |
| MATERIAL SEE SPECIFICATIONS | ALL DIMENSIONS DISPLAYED ON THIS DRAWING ARE FOR REFERENCE ONLY | DRFT IK DATE 04/07/99 DSGN SCALE 1=1.5 | DESCRIPTION RSM-2RKM 40 | | |
| FINISH SEE SPECIFICATIONS | CONTACT TURCK FOR MORE INFORMATION | UNIT OF MEASUREMENT MILLIMETER [INCH] DO NOT SCALE THIS DRAWING | | IDENTIFICATION NO. U0140 | REV D |
| D DRAWING PROCESSED AS PART OF ECO 33971 | CBM 04/07/11 33971 | FILE: U0140 | | SHEET 1 OF 1 | |