

Your Global Automation Partner

TURCK

Isolating Transducer IMX12-AI... | IM12-AI...

Safety Manual

Contents

1	About this document	5
2	Scope	5
3	Safety Integrity Level	6
4	Product description	6
4.1	Safety Function	7
4.2	Safe State	8
5	Safety Planning	8
5.1	Architectural specifications	8
5.2	Assumptions	9
5.3	FMEDA results	9
5.4	Example for using the results	9
5.4.1	Average of probability of failure on demand (High Demand Mode)	9
5.4.2	Average frequency of dangerous failure (Low Demand Mode)	9
6	Operation instructions	10
6.1	General	10
6.2	Before operation	11
6.3	Operation	12
6.4	After operation	13
7	Appendix: Connection and wiring diagrams	14
7.1	IMX12-AI01-2I-2IU	14
7.2	IM12-AI01-2I-2IU	15
7.3	IMX12-AI01-1I-1IU	15
7.4	IM12-AI01-1I-1IU	16
7.5	IMX12-AI01-1I-2IU	16
7.6	IM12-AI01-1I-2IU	17
8	Appendix: Terms and abbreviations	17
9	Appendix: Proof tests	18
10	Appendix: Document history	19



1 About this document

This safety manual contains all information that is required by users to operate the device in functional safety systems. Read this manual carefully before using the device.

This document addresses only functional safety according to IEC 61508. Other aspects, such as intrinsic safety, are not considered.

All instructions must be followed in order to assure functional safety.

Always make sure that this is the latest version of the safety manual at www.turck.com. The English version is considered the definitive document. Every care was taken in the production of the translations of this document. If there is any uncertainty in its interpretation, refer to the English version of the safety manual or contact Turck directly.

2 Scope

This safety manual is valid for the following devices.

Product Number	Product Name	Number of channels	Terminal Block Design	Power-Bridge-connection	Intrinsic Safety
7580300	IMX12-AI01-1I-2IU-HPR/24VDC	1	screw clamps	yes	yes
7580301	IMX12-AI01-1I-2IU-H0/24VDC	1	screw clamps	no	yes
7580302	IMX12-AI01-1I-2IU-HPR/24VDC/CC	1	spring type terminals	yes	yes
7580303	IMX12-AI01-1I-2IU-H0/24VDC/CC	1	spring type terminals	no	yes
7580304	IMX12-AI01-2I-2IU-HPR/24VDC	2	screw clamps	yes	yes
7580305	IMX12-AI01-2I-2IU-H0/24VDC	2	screw clamps	no	yes
7580306	IMX12-AI01-2I-2IU-HPR/24VDC/CC	2	spring type terminals	yes	yes
7580307	IMX12-AI01-2I-2IU-H0/24VDC/CC	2	spring type terminals	no	yes
7580312	IMX12-AI01-1I-1IU-HPR/24VDC	1	screw clamps	yes	yes
7580313	IMX12-AI01-1I-1IU-H0/24VDC	1	screw clamps	no	yes
7580314	IMX12-AI01-1I-1IU-HPR/24VDC/CC	1	spring type terminals	yes	yes
7580315	IMX12-AI01-1I-1IU-H0/24VDC/CC	1	spring type terminals	no	yes
7580320	IM12-AI01-1I-2IU-HPR/24VDC	1	screw clamps	yes	no
7580321	IM12-AI01-1I-2IU-H0/24VDC	1	screw clamps	no	no
7580322	IM12-AI01-1I-2IU-HPR/24VDC/CC	1	spring type terminals	yes	no
7580323	IM12-AI01-1I-2IU-H0/24VDC/CC	1	spring type terminals	no	no
7580324	IM12-AI01-2I-2IU-HPR/24VDC	2	screw clamps	yes	no
7580325	IM12-AI01-2I-2IU-H0/24VDC	2	screw clamps	no	no
7580326	IM12-AI01-2I-2IU-HPR/24VDC/CC	2	spring type terminals	yes	no
7580327	IM12-AI01-2I-2IU-H0/24VDC/CC	2	spring type terminals	no	no
7580332	IM12-AI01-1I-1IU-HPR/24VDC	1	screw clamps	yes	no
7580333	IM12-AI01-1I-1IU-H0/24VDC	1	screw clamps	no	no
7580334	IM12-AI01-1I-1IU-HPR/24VDC/CC	1	spring type terminals	yes	no
7580335	IM12-AI01-1I-1IU-H0/24VDC/CC	1	spring type terminals	no	no

3 Safety Integrity Level

This devices are related to a SIL of

SIL2

4 Product description

The IMX-AI isolating transducers are used to operate intrinsically safe passive 2-wire transducers in the Ex area and to transmit the galvanically isolated measuring signals 1:1 to the non-Ex area. Alternatively, it is also possible to transfer the normalized current signals of active sensors from the Ex area to the non-Ex area.

The measuring transducer can actively output the transmitted current at the output (source) or as a sink if connected to an external voltage source. The switch between the two operating modes is automatic depending on the external circuitry.

The 2I-2IU variant is provided with two independent channels with identical functions.

The 1I-2IU provides one channel and transfers the input signal to two outputs.

The 1I-1IU is a one channel variant, transferring the input signal to the output.

Each channel of the isolating transducers is provided with input circuit monitoring. A fault in the input circuit (wire break, short circuit) is indicated via an LED on the front of the device.

4.1 Safety Function

Variants	Assignment	Safety Function
IMX12-AI01-1I-2IU	E1 → A1	The current present in the input circuit is transmitted to the output circuit proportionally at an accuracy of 0,4 mA within 50ms. For use in safety-related configurations, the input circuit must be connected with a passive or active transmitter, which detects an input current in the input circuit between 3.8 mA and 20.5 mA as a valid measured value according to NE43
IM12-AI01-1I-2IU	E1 → A1	The current present in the input circuit is transmitted to the output circuit proportionally at an accuracy of 0,4 mA within 50 ms. For use in safety-related configurations, the input circuit must be connected with a passive or active transmitter, which detects an input current in the input circuit between 3.8 mA and 20.5 mA as a valid measured value according to NE43
IMX12-AI01-2I-2IU	E1 → A1 E2 → A2	The current present in the input circuit is transmitted to the output circuit proportionally at an accuracy of 0,4 mA within 50ms. For use in safety-related configurations, the input circuit must be connected with a passive or active transmitter, which detects an input current in the input circuit between 3.8 mA and 20.5 mA as a valid measured value according to NE43
IMX12-AI01-2I-2IU	E1 → A1 E2 → A2	The current present in the input circuit is transmitted to the output circuit proportionally at an accuracy of 0,4 mA within 50 ms. For use in safety-related configurations, the input circuit must be connected with a passive or active transmitter, which detects an input current in the input circuit between 3.8 mA and 20.5 mA as a valid measured value according to NE43
IM12-AI01-1I-1IU	E1 → A1	The current present in the input circuit is transmitted to the output circuit proportionally at an accuracy of 0,4 mA within 50 ms. For use in safety-related configurations, the input circuit must be connected with a passive or active transmitter, which detects an input current in the input circuit between 3.8 mA and 20.5 mA as a valid measured value according to NE43
IM12-AI01-1I-1IU	E1 → A1	The current present in the input circuit is transmitted to the output circuit proportionally at an accuracy of 0,4 mA within 50 ms. For use in safety-related configurations, the input circuit must be connected with a passive or active transmitter, which detects an input current in the input circuit between 3.8 mA and 20.5 mA as a valid measured value according to NE43

The transmitter can be powered by an external power supply (active 2 wire transmitter) or can be powered by the isolating transducer (passive 2 wire transmitter).

It is also necessary for the output circuit [A1] and if applicable [A2] to be connected to a load resistance which meets the requirement (< 800 Ω).

The Power Bridge is not part of the safety-function.

The two channels on the 2-channel devices are not used for the same safety function, e.g. to increase the hardware fault tolerance to achieve a higher SIL, as they contain common components.

An error acknowledgment is not necessary. The device starts operating independently again after the fault is no longer present.

The user must detect currents $< 3.6 \text{ mA}$ and $> 21 \text{ mA}$ and maintain the safe state of the system.

4.2 Safe State

The safe state is defined as the output reaching the user defined threshold value.

5 Safety Planning

This chapter provides information for planning a safety-related loop.

The device is not specified for a certain application. Make sure that the data provided in this chapter is valid for your target application.

Special application-specific factors may cause the premature wear of the device and must be taken into consideration when planning systems; take special measures to compensate for a lack of experience based values, e.g. through implementation of shorter test intervals. The suitability for specific applications must be assessed by considering the particular overall safety-related system with regard to the requirements of IEC 61508.

Safety-planning must only be carried out by trained and qualified personnel.
In case of doubt contact Turck directly.

5.1 Architectural specifications

Due to architectural consideration the following characteristic are specified:

Type	A
HFT	0

Experience has shown that the useful lifetime often lies within a range of 8 to 12 years. It can be significantly less if elements are operated near their specification limits. However, it can be extended by appropriate measures. For example, heavy temperature fluctuations could potentially decrease the useful lifetime, as constant temperature below 40 °C could potentially increase the useful lifetime.

5.2 Assumptions

- Failure rates are constant for 10 years, wear out mechanisms are not included
- Propagation of failures is not relevant
- External power supply failure rates are not included
- All components that are not part of the safety function and cannot influence the safety function (feedback immune) are excluded.
- Only one input and one output are part of the safety function
- The application program in the safety logic solver is configured according to NAMUR NE43 to detect under-range and over-range failures of the 4...20 mA output signal, and does not automatically trip on these failures; therefore these failures have been classified as dangerous detected failures.

5.3 FMEDA results

The following safety characteristic are results of FMEDA.

λ_{SD}	λ_{SU}	λ_{DD}	λ_{DU}	No effect	SFF	DC
0 FIT	0 FIT	269 FIT	110 FIT	516	71 %	71 %

The stated Safe Failure Fraction (SFF) is for reference only. The complete subsystem will need to be evaluated to determine the overall SFF.

The failure rates used in this analysis are the basic failure rates from the Siemens standard SN 29500 based on the average ambient temperature of components of 40°C.

“No effect” is a failure mode of a component that plays part in implementing the safety function but is neither a safe nor a dangerous failure. According to IEC 62061, it would be possible to classify the “No effect” failures as “Safe Undetected” failures. Not doing so represents the worst-case.

A DD failure is defined as a failure that causes the output signal to go to the minimum output current (< 3.6 mA)

5.4 Example for using the results

5.4.1 Average of probability of failure on demand (High Demand Mode)

The PFH values are based on a worst-case diagnostic test rate and a reaction time of 50ms. The ratio of the diagnostic test rate to the demand rate shall equal or exceed 100.

PFH
1,0996 E-07 1/h

5.4.2 Average frequency of dangerous failure (Low Demand Mode)

With the FMEDA results and the values specified in the following table the average frequency of dangerous failure can be calculated exemplarily:

T1	8760h
MTTR	24h

PFDavg
4.91 E-04

6 Operation instructions

6.1 General

- ▶ The device must be registered online: www.turck.com/SIL or with the supplied SIL registration card. This must be filled in with all required information first of all and sent to Turck.
- ▶ The device must only be carried out, fitted, installed, operated, commissioned and maintained by trained and qualified personnel.
- ▶ The device is not specified for a certain application. Make sure that application-specific aspects are considered.
- ▶ Data from other documents, e.g. data sheets, is not valid for functional safety operation. Devices must be used in cabinets in an typical industrial field environment only. The following restrictions describe the operation and storage conditions:

- ▶ Ensure that the environment complies with the following ratings

Minimum ambient temperature	-25 °C
Maximum ambient temperature	70 °C
Minimum storage temperature	-40 °C
Maximum storage temperature	80 °C
Maximum air humidity	95 %
Minimum air pressure	80 kPa
Maximum air pressure	110 kPa

- ▶ The average temperature over a long period of time directly on the exterior sidewall of the housing must be maximum 40 °C.
 - The temperature on the exterior sidewall of the housing can deviate considerably from the temperature in the control cabinet.
 - The temperature on the exterior sidewall of the housing must be observed in a steady state.
 - In case the temperature on the exterior sidewall of the housing is higher, the failure rates from „5.3 FMEDA results“ on page 9 must be adjusted:
For a higher average temperature of 60 °C on the exterior sidewall of the housing, the failure rates are multiplied by an experience factor of 2.5.
- ▶ Ensure that sufficient heat dissipation is provided.
- ▶ Protect the device from radiated heat and severe temperature fluctuations.
- ▶ Protect the device from dust, dirt, moisture, shock, vibration, chemical stress, increased radiation and other environmental influences.
- ▶ Ensure a degree of protection of at least IP20 according to IEC 60529 at the mounting location.
- ▶ Ensure that the electromagnetic stress does not increase the requirements of IEC 61326-3.1.
- ▶ If there is a visible error, e.g. defective housing the device must not be used.
- ▶ During operation of the device, surface temperatures may occur that could lead to burns if touched.
- ▶ The device must not be repaired. If problems occur with regard to functional safety, Turck must be notified immediately and the device must be returned immediately to:

Hans Turck GmbH & Co. KG
 Witzlebenstraße 7
 45472 Mülheim an der Ruhr
 Germany

6.2 Before operation

- Fasten the device to a rail according EN 60715 (TH35) as follows:

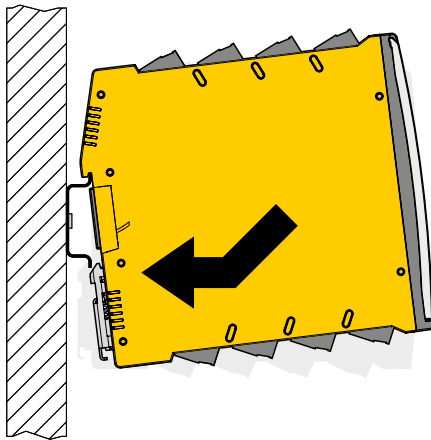

Fig. 1: Fasten the device

- Connect cables according to the wiring diagrams in „7 Appendix: Connection and wiring diagrams“ on page 14
- Use cables with Terminal cross section
 - rigid: 0.2 mm² to 2.5 mm² or
 - flexible 0.2 mm² to 2.5 mm²
- When wiring with stranded wires: Fix the wiring ends with ferrules.

Connection via screw terminals:

- Insert the stripped cable ends (7 mm) in the guides of the cable glands.
- Fasten the screws with a screwdriver (max. tightening torque 0.5 Nm) to fix the cable ends.

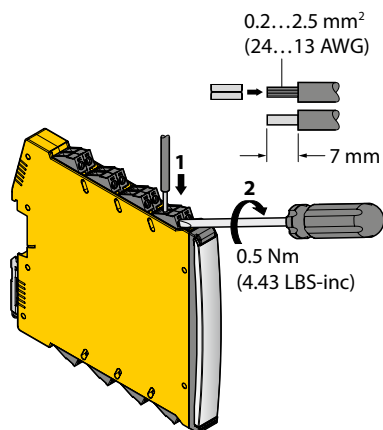

Fig. 2: Connection with screw terminals

Connection with spring-type terminals;

- Push the opening lever with a suitable screwdriver.
- Insert the stripped cable ends (7 mm) in the guides of the cage clamp terminals.
- Pull the screwdriver to fix the cable ends.

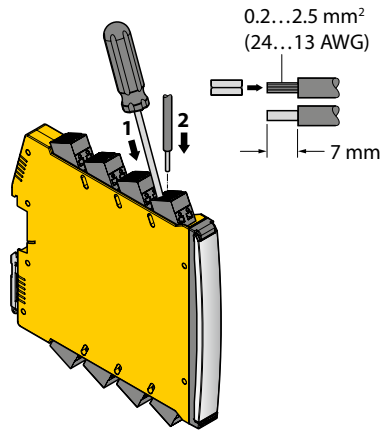

Fig. 3: Connection with spring-type terminals

- Make sure that only suitable equipment, e.g. sensors, are connected to the device (see „7 Appendix: Connection and wiring diagrams“ on page 14).
- Make sure that a suitable power supply with the following characteristic is used:

Minimum voltage	10 VDC
Maximum voltage	30 VDC
Minimum Power	4 W

6.3 Operation

- If the device is used in low demand mode, proof tests shall be executed periodically according to T1 (see „9 Appendix: Proof tests“ on page 18).
- Ensure that the plug connections and cables are always in good condition.
- The device must be replaced immediately if the terminals are faulty or the device has any visible faults.
- If cleaning is required, do not use any liquid or statically charging cleaning agent. Perform proof tests after each cleaning (see „9 Appendix: Proof tests“ on page 18).

The device shall be locked against unintended operation/modification.

6.4 After operation

- Undo the terminal connection on the device.
- Remove the device from its rail fixing as shown in the figure:

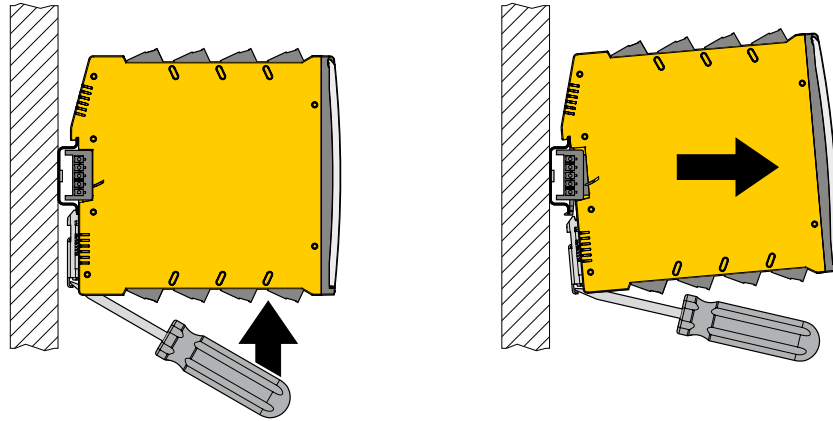

Fig. 4: Remove device

- Ensure the dispose of the device.

7 Appendix: Connection and wiring diagrams

The pin number assignment can be found at the front label.

Load resistance (A1, A2): $\leq 800 \Omega$

At the terminals of the input circuit [E1] and [E2] a supply voltage for a passive transmitter of at least 17 V is provided at 20 mA loop current.

A current in the input circuit [E1] and [E2] between 3.8 mA and 20.5 mA is recognized in accordance with NE43 as valid measured value.

7.1 IMX12-AI01-2I-2IU

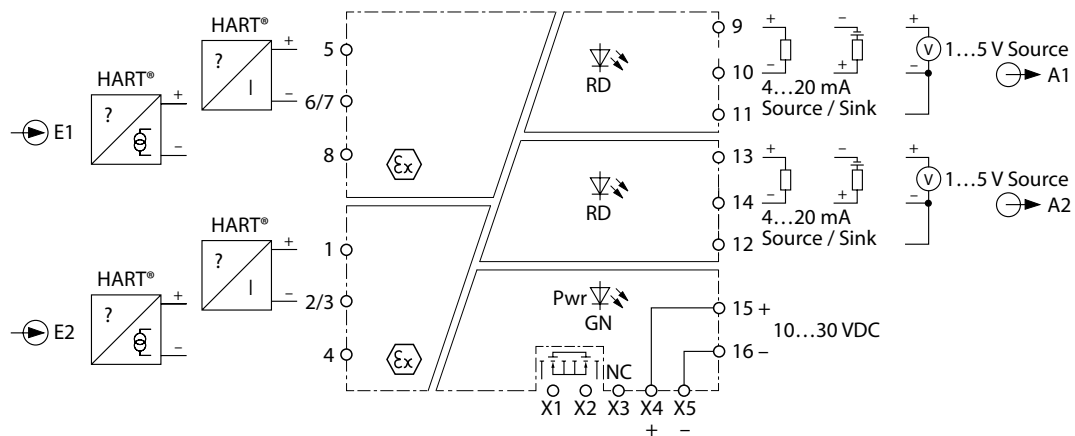

Fig. 5: IMX12-AI01-2I-2IU

7.2 IM12-AI01-2I-2IU

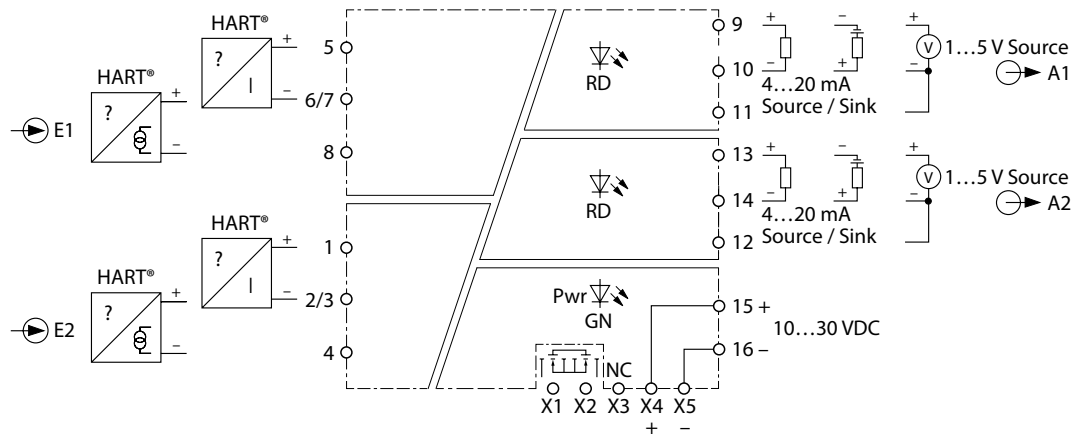

Fig. 6: IM12-AI01-2I-2IU

7.3 IMX12-AI01-1I-1IU

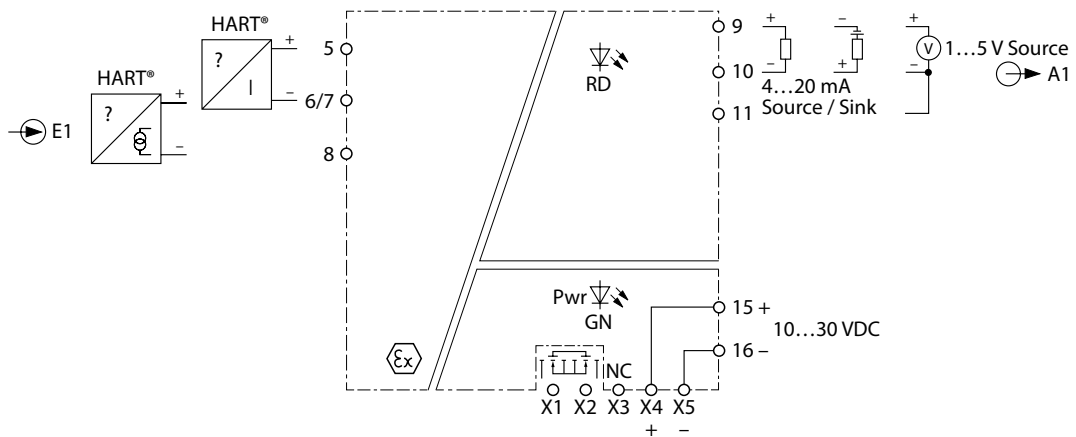

Fig. 7: IMX12-AI01-1I-1IU

7.4 IM12-AI01-1I-1IU

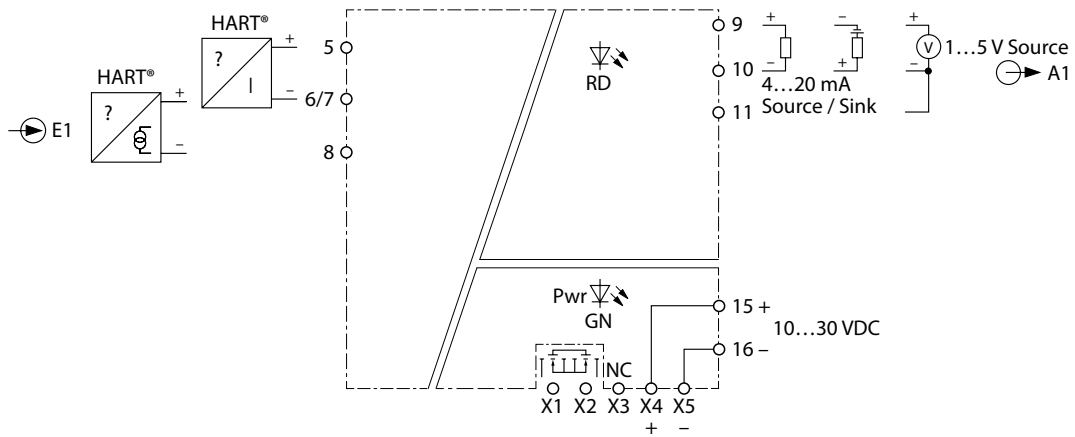

Fig. 8: IM12-AI01-1I-1IU

7.5 IMX12-AI01-1I-2IU

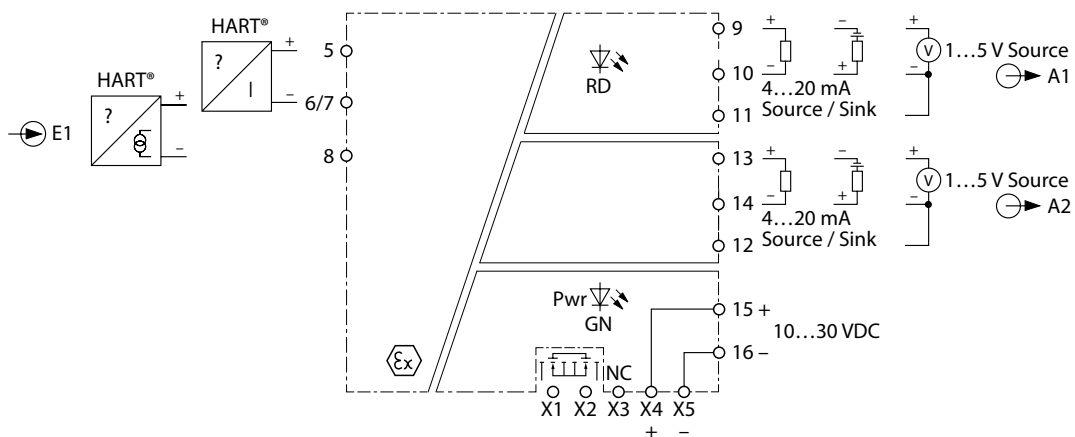

Fig. 9: IMX12-AI01-1I-2IU

7.6 IM12-AI01-1I-2IU

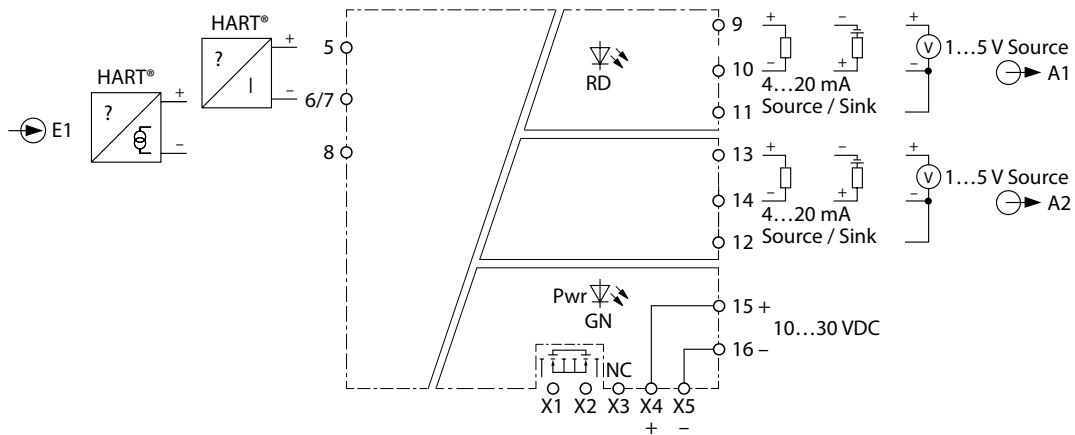

Fig. 10: IM12-AI01-1I-2IU

8 Appendix: Terms and abbreviations

DC	Diagnostic Coverage
FIT	1 FIT is 1 failure per 10E09 hours
FMEDA	Failure Modes, Effects and Diagnostic Analysis
HFT	Hardware failure tolerance
λ_{AU}	Undetected Annunciation failure rate (per hour) Annunciation failures do not directly impact safety but impact the ability to detect a future fault (such as a fault in diagnostic circuit).
λ_{DD}	Detected dangerous failure rate (per hour)
λ_{DU}	Undetected dangerous failure rate (per hour)
λ_{SD}	Detected safe failure rate (per hour)
λ_{SU}	Undetected safe failure rate (per hour)
MTTR	Mean time to restoration (hour)
PFD_{avg}	Average probability of failure on demand
PFH	Probability of dangerous failure per hour
SFF	Safe Failure Fraction
SIL	Safety Integrity Level
T1	Proof test interval (hour)
Type A	“Non-complex” element (all failure modes are well defined); for details see 7.4.4.1.2 of IEC 61508-2
Type B	“Complex” element (using micro controllers or programmable logic); for details see 7.4.4.1.3 of IEC 61508-2

9 Appendix: Proof tests

Proof tests shall be undertaken to reveal dangerous faults which are undetected by diagnostic tests. This means that it is necessary to specify how dangerous undetected faults which have been noted during the FMEDA can be detected during proof testing.

Ensure that the proof test is only carried out by qualified personnel.

A suggested proof test consists of the following steps:

Step	Action
1.	Bypass the safety function and take appropriate action to avoid a false trip.
2.	Provide appropriate input-/control signals to the interface modules and verify the expected signal input/output conditions for the interfaces.
3.	Verify if internal fault detection is working in case it is activated.
4.	Provide appropriate input-/control signals to the interface modules and verify that the safety function is carried out correctly.
5.	Remove the bypass and otherwise restore normal operation.

Once the test has been completed, document and archive the results.

10 Appendix: Document history

Document Version	Date	Modifications
1.0	2016-01-20	Initial version
2.0	2018-07-13	More detailed explanation of temperature conditions
3.0	2019-01-03	<ul style="list-style-type: none"> - TÜV Assessment: - In Safety Function note added that external supply and supply via device is possible - In Safety Function note added that only one channel may be used - Product Description -1-2IU deleted - Note with safety function that currents < 3.6 mA are added (from specifications) Safe State adapted (from FMEDA Report) In Assumptions "User must detect < 3.6 mA" added (from FMEDA Report) In FMEDA results DD failures explained (< 3.5 mA) In Terms "Type B" added - cable ends set to 7mm - useful lifetime updated - headings low/high demand corrected - terms updated - note for 61326-3-1 modified: exceed (not increase) - 1 channel device added - splitter devices added - IM (non-X) devices added - power rail renamed in power bridge - cage clamps renamed in spring type - in chapter 2 Intrinsic Safety added

11 Appendix: Certificate

The certificate can be found on the internet at www.turck.com.

TURCK

Over 30 subsidiaries and over
60 representations worldwide!

D201481 | 2019/01



www.turck.com