

Your Global Automation Partner

TURCK

TBPN-L1-FDIO1-2IOL

Safety Block I/O Module

Safety manual - Translation



Table of Content

1	About this document	5
2	Scope	5
3	Safety Integrity Level/Performance Level/Category	5
4	Product description	6
4.1	Intended use	6
4.1.1	Foreseeable misuse	6
4.2	Device overview	6
4.3	Type plate	7
4.4	Switches and connectors	7
4.5	Block diagram	7
5	Safety function	8
5.1	Safe status	8
5.2	Fatal Error	8
6	Safety planning	8
6.1	Prerequisites	8
6.2	Reaction time	8
6.3	Safety characteristic data	9
7	Operating instructions	9
7.1	General	9
7.2	Before operation	10
7.2.1	Mounting	10
7.2.2	Connection	11
7.2.3	Address assignment	12
7.2.4	Configuring	12
7.3	Operation	13
7.3.1	Indication elements	13
7.3.2	Output error behavior	14
7.3.3	Decommissioning	14
8	Appendix: Wiring diagram	14
8.1	Ethernet	14
8.2	Power supply	14
8.3	Safety inputs	14
8.4	Safety in-/outputs	15
8.5	DXP	15
8.6	IO-Link	15
9	Appendix: Connection examples	16
9.1	Inputs	16
9.2	Outputs	16

10	Appendix: Designations and abbreviations	17
11	Appendix: Function tests	17
12	Appendix: Document history	17
13	Appendix: Technical data	18
14	Appendix: Declaration of Conformity	20

1 About this document

This safety manual contains all information that is required by users to operate the device in functional safety systems. Read this manual carefully before using the device.

This document addresses only functional safety according EN ISO 13849-1 and EN/IEC 61508. Other issues are not considered.

All instructions must be followed in order to assure functional safety.

Always make sure that this is the latest version of the safety manual at www.turck.com. The German version is considered the definitive document. Every care was taken in the production of the translations of this document. If there is any uncertainty in its interpretation, refer to the German version of the safety manual or contact TURCK directly.

2 Scope

This safety manual is valid for the Turck PROFIsafe device TBPN-L1-FDIO1-2IOL.

3 Safety Integrity Level/Performance Level/Category

The devices are rated for applications up to:

- SIL3 according to EN/IEC 61508 and EN/IEC 62061
- Category 4/PLe according to EN ISO 13849-1

4 Product description

The TBPN-L1-FDIO1-2IOL is a safety block I/O module for safety applications with PROFIsafe over PROFINET.

The device provides two safety SIL3-inputs (FDI) to connect 2-channel mechanical safety switches and electronic safety sensors (OSSD).

Two further SIL3-channels (FDX) can be freely used as inputs (FDI) or outputs (FDO). The safety outputs serve for the safe shutdown of loads (resistive up to 2 A).

For non-safety functions, the device provides four universal in-/outputs (DXP) at C4 as well as two IO-Link master channels (IOL) at C6 and C7 for connecting IO-Link sensors and IO-Link hubs. Additionally, the IO-Link slots each provide one digital in-/output at pin 2.

The non-safety ports C4, C5 and C7 can be switched-off safe via the internal outputs FSO0 and FSO1 (see „4.5 Block diagram“ on p. 7). This allows a safety shutdown of the connected sensors and actuators.

4.1 Intended use

The TBPN-L1-FDIO1-2IOL is a decentralized PROFIsafe safety module. It collects field signals and transfers the signals safe to a PROFINET master.

Thanks to an extended temperature range from -40 to +70 °C and the protection class IP65/IP67/IP69K, it can be used in harsh environments directly on the machine.

The device is specified for the operation in industrial environment. If it is used in residential or mixing areas, radio interference may occur.

4.1.1 Foreseeable misuse

The device is not suitable for:

- The use in explosive areas
- Outdoor use
- The permanent use in liquids

4.2 Device overview

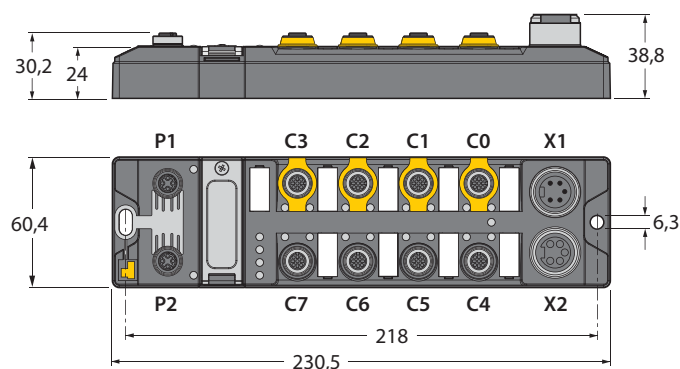

4.3 Type plate

TBPN-L1-FDIO1-2IOL

Ident-No.: 6814053 Hans Turck GmbH & Co. KG
 Charge code: Witzlebenstr.7
 YoC: D-45472 Mülheim a. d. Ruhr
 www.turck.com

4.4 Switches and connectors

		Meaning
	X1	Power IN
	X2	Power OUT
	C0	FDI0/1, safety input
	C1	FDI2/3, safety input
	C2	FDX4/5, safety in-/output
	C3	FDX6/7, safety in-/output
	C4	DXP8/9, standard in-/outputs (safe shutdown via FSO0)
	C5	DXP10/11, standard in-/outputs (safe shutdown via FSO0 possible)
	C6	IOL, IO-Link port1
	C7	IOL, IO-Link port2 (safe shutdown via FSO1 possible)
	F-Address	Rotary coding switch for address setting for PROFI-safe (F-address setting)
	P1	Ethernet 1
	P2	Ethernet 2
	FE	Functional earth

4.5 Block diagram

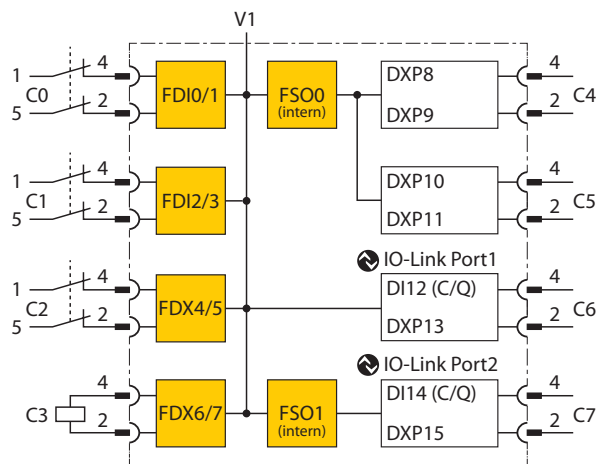

5 Safety function

The device provides two safe digital SIL3 inputs (FDI) and two SIL3-connectors (FDX), configurable as in- or outputs.

The following devices can be connected to the safety inputs:

- Max. four 2-channel safety switches and sensors
- Contact switches, e.g. Emergency stop buttons, protective door switches
- Sensors with OSSD switching outputs with test signals
- Sensors with OSSD switching outputs without test signals

The two safety SIL3 outputs can be used PP- or PM-switching

Additionally, the DXP channels (C4 and C5) as well as the second IO-Link port (C7) can be switched-off safe via the internal outputs FSO0 and FSO1 (see „4.5 Block diagram“ on p. 7).

5.1 Safe status

In the safe state the device outputs are in LOW-state (0).
The inputs report a LOW-state (0) to the logic.

5.2 Fatal Error

The following errors lead to Fatal Error and thus to the safe state:

- Incorrect wiring at the output (e.g. capacitive load, energetic recovery)
- Incorrect power supply
- Strong EMC disturbances
- Internal device error

6 Safety planning

The operator is responsible for the safety planning.

6.1 Prerequisites

- ▶ Perform a hazard and risk analysis.
- ▶ Develop a safety concept for the machine or plant.
- ▶ Calculate the safety integrity for the complete machine or plant.
- ▶ Validate the complete system.

6.2 Reaction time

If the system is operated with higher availability, the max. reaction time is extended (see „6.3 Safety characteristic data“ on p. 9).

In addition to the reaction time in the device, reaction times of the further PROFIsafe components have to be considered eventually. Please find the respective information in the technical data of the respective devices.

Further information about the reaction time can be found in the online help for the software „Turck Safety Configurator“ (see also „7.2.4 Configuring“ on p. 12).

6.3 Safety characteristic data

Characteristic data	Value	Standard
Performance Level (PL)	e	EN/ISO 13849-1
Safety category	4	EN/ISO 13849-1
Safety Integrity Level (SIL)	3	IEC/EN 61508
SIL CL	3	EN/IEC 62061
PFH _D	4×10^{-9} 1/h	IEC/EN 61508; EN/ISO 13849-1
PFD	5×10^{-6}	IEC/EN 61508
MTTF _D	> 2500 years	EN/ISO 13849-1: 2016
DC	99 %	
Permissible duration of use (TM)	20 years	EN ISO 13849-1
Maximum on-time	12 months	IEC/EN 61508
Max. reaction time in case of shutdown		
PROFIsafe > local output	25 ms	IEC/EN 61508
Local input > PROFIsafe	20 ms	
Local input <> local output	35 ms	

7 Operating instructions

7.1 General

- ▶ In case of a safety application, the device has to be registered under www.turck.de/SIL.
- ▶ The device must only be mounted, installed, operated and maintained by trained and qualified personnel.
- ▶ The device is not specified for a certain application. Make sure that application-specific aspects are considered.
- ▶ Before expiration of the permissible duration of use the device must be replaced (see „6.3 Safety characteristic data“ on p. 9).
- ▶ Execute a functional test every twelve months.
- ▶ The device must not be repaired. If problems occur with regard to functional safety, TURCK must be notified immediately and the device must be returned immediately to:

Hans Turck GmbH & Co. KG
 Witzlebenstraße 7
 45472 Mülheim an der Ruhr
 Germany

- ▶ In case of device errors which lead to the safe state, measures have to be taken which guarantee the safe state for the further operation of the complete control system.
- ▶ Dangerous failures have to be reported immediately to Turck.

7.2 Before operation

The operator of the machine or the plant in which the safety related system is used, is responsible for the correct and safe overall function of every single safety component.

- ▶ Carry out a validation of the safety category for the complete system depending on the selection of the used safety components.

7.2.1 Mounting



ATTENTION

Mounting on uneven surfaces

Damage to the device due to mechanical tensions

- ▶ Mount the device onto an even mounting surface.
- ▶ Use two M6 screws to mount the device.
- ▶ Mount the device onto a pre-drilled and grounded mounting surface. The maximum tightening torque for the screws is 1.5 Nm.

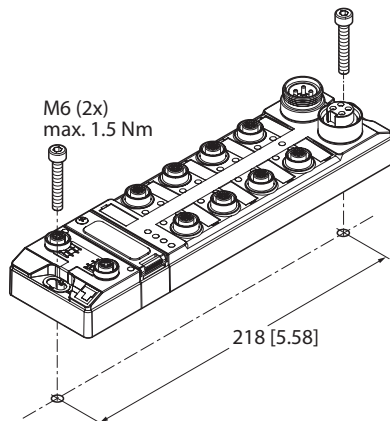

7.2.2 Connection



ATTENTION

Loss of protection class IP65/IP67/IP69K

Damage to the device due to invasive foreign material or liquids

- Seal unused sockets, connectors and covers carefully.
- Use appropriate 7/8" sealing caps, e.g. type RKMV-CCC (not included in the scope of delivery).
- Use appropriate M12-sealing caps (included in the scope of delivery).

Connect the Ethernet

The maximum tightening torque for the Ethernet connectors is 0.6 Nm.

- Connect the device to the field bus according to the pin assignment (see „1 About this document“ on p. 5).

Connect power supply

The externally connectable circuits have to be securely disconnected from the mains supply.



WARNING

Wrong 24 V power supply unit

Dangerous voltage and loss of functional safety

- Exclusively use power supply units with PELV voltage according to EN50178 (PELV).
- Assure that the maximum output voltage of 60 V is not exceeded, even in case of an error.

- Connect the device to the power supply according to the pin assignment (see „8 Appendix: Wiring diagram“ on p. 14). The female connectors at the device have the following function:

- X1: Voltage IN
- X2: Conduct voltage to next node

Connect sensors and actuators



DANGER

Wrong supply of sensors and actuators

Danger to life due to external supply

- Guarantee that no external supply is used.
- Guarantee that the inputs are only supplied through the same 24 V source as the device itself.



DANGER

Connection of fast reacting loads

Danger to life due to connection failures

- Use loads with mechanical or electrical inertia.
- Positive and negative test pulses have to be tolerated.

The maximum tightening torque for the M12 connectors is 0.8 Nm.

- Connect the sensors and actuators to the in- and outputs according to the pin assignment (see „8 Appendix: Wiring diagram“ on p. 14).

7.2.3 Address assignment

- Set the F-address (PROFIsafe address) for the TBPN-L1-FDIO1-2IOL using the three rotary coding switches under the cover at the device.

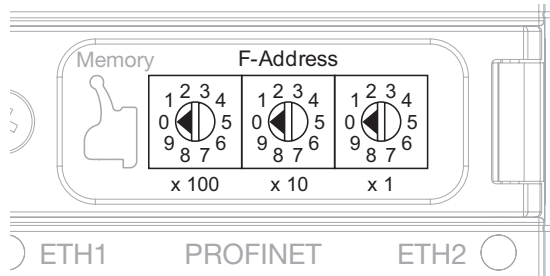

The module is delivered with the switch position 0. The address 0 and the addresses ≥ 900 are no valid F-addresses.

Switch position	Meaning
0	State of delivery, no valid address
1...899	F-address, the setting is accepted after a device restart
900	Factory Reset: reset of the device to factory settings
901	Erase Memory Stick: deletes the content of the configuration memory

7.2.4 Configuring

The safety function of the safe channels can only be configured via the software Turck Safety Configurator.

After the configuration, the device generates a CRC and a configuration protocol. This protocol has to be checked and validated by the user. The CRC is stored as reference in the configuration of the PROFIsafe control and guarantees the correct safety function.





















Further information about the software can be found in the online help.















The configuration of the safe I/O channels set via the Turck Safety Configurator is automatically stored to a pluggable memory stick which is part of the scope of delivery. In case of a device exchange, the device configuration can be transferred to another device using the memory stick.

7.3 Operation

7.3.1 Indication elements

During operation, the LEDs have the following functions:

LED	Color	Meaning
ETH1	 green	Link established, 100 Mbps
	 green blinking	Ethernet Traffic, 100 Mbps
	 yellow	Link established, 10 Mbps
	 yellow blinking	Ethernet Traffic, 10 Mbps
ETH2	 green	Link established, 100 Mbps
	 green blinking	Ethernet Traffic, 100 Mbps
	 yellow	Link established, 10 Mbps
	 yellow blinking	Ethernet Traffic, 10 Mbps
PWR	 green	Voltage OK
	 red	Power supply faulty
ERR	 green	No diagnostics
	 red	Diagnostics pending
BUS	 green	Active connection to a master
	 green blinking	Device ready for operation
	 red	IP address conflict or restore mode or timeout
	 red blinking	Blink-/wink-command active
	 green/red blinking	Autonegotiation and/or waiting for DHCP-/BootP-address assignment.
0...3	 green	Channel active
	 green blinking	Self-test
	 red	Discrepancy
	 red blinking	Cross-connection

LED	Color	Meaning
4...7	 green	Channel active
	 green blinking	Self-test (input only)
	 red	Discrepancy, overload (output only)
	 red blinking	Cross-connection
8...11	 green	Channel active
	 red	Overload (output only)
	 red blinking	Channel inactive (input only), overload of supply
	 green permanent,  red blinking	Channel active and overload of supply (input only)
		
12...15	 green	IO-Link communication or DI active
	 red	Error
0...7	 red all blinking alternating	Fatal Error
WINK	 white flashing	Helps to localize the module if the Blink/Wink command is active.

7.3.2 Output error behavior

In case of an error a switched-off output can be switched on for ≤ 1 ms.

7.3.3 Decommissioning

The decommissioning is described in the user manual (D301379).

8 Appendix: Wiring diagram

The pin assignments can be found on the side of the device.

8.1 Ethernet

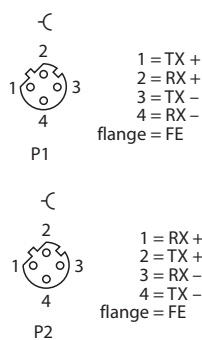

8.2 Power supply

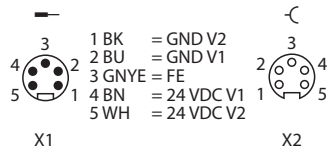

8.3 Safety inputs

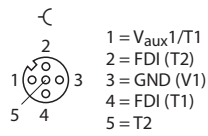

8.4 Safety in-/outputs

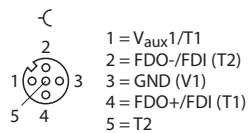

NOTE

For PM-switching outputs, connect the negative pole of the load to the M-connector of the respective output (pin 2).

8.5 DXP

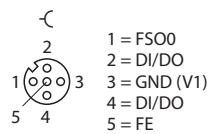

8.6 IO-Link

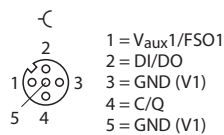

9 Appendix: Connection examples

9.1 Inputs

Safe equivalent inputs for potential free contacts (NC/NC)

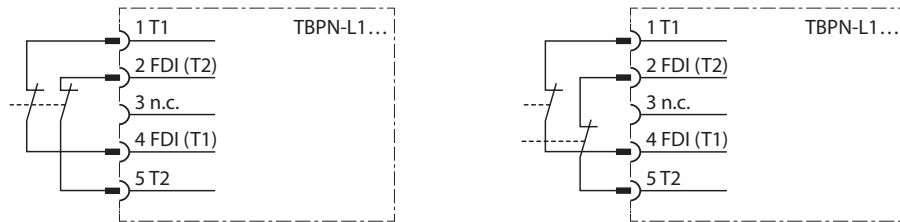

Safe antivalent input for potential free contacts (NC/NO)

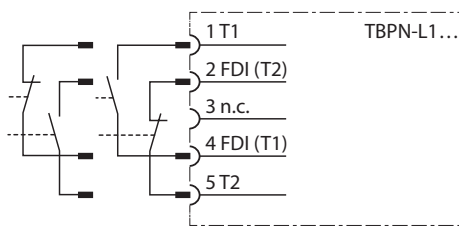

Safe electronic input (OSSD)

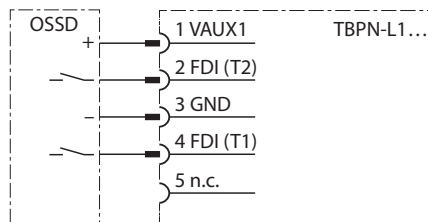

9.2 Outputs

Safe output PP-switching

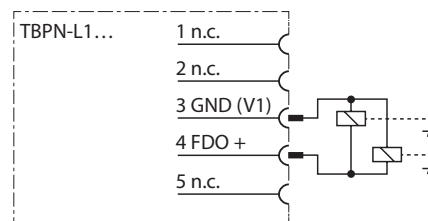

For PP-switching outputs, connect the negative pole of the load to the GND of the respective output (pin 3). Another connection to the GND of the power supply unit is not permitted!

The wiring has to allow an exclusion of faults regarding cross connection.

Safe output PM-switching

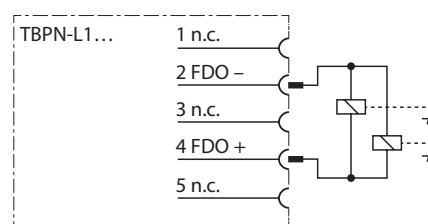

For PM-switching outputs, connect the negative pole of the load to the M-connector of the respective output (pin 2).

10 Appendix: Designations and abbreviations

Abbreviation	Meaning
DC	Diagnostic Coverage
E/E/PE-system	Electrical/electronic/programmable electronic system
HFT	Hardware failure tolerance
MTTF _d	Mean Time To Failure Dangerous
PFD	Probability of dangerous failure on demand
PFH	Average frequency of dangerous failure per hour
PL	Performance Level
SIL	Safety Integrity Level

11 Appendix: Function tests

Ensure that the function test is only carried out by qualified personnel.
A suggested function test consists of the following steps:

Step	Action
1	Switch every safety related input at least once a year.
2	Control the switching behavior by monitoring the output circuits.
3	Observe the maximum duty cycle and the total operation time depending on the selected PFD value.
4	If the maximum duty cycle is reached: request the shutdown function in order to check the function of the safety system

Once the test has been completed, document and archive the results.

12 Appendix: Document history

Version	Date	Modifications
1.0	2016-06-30	First version
2.0	2018-01-17	- Safety characteristic data updated - Connection examples extended

13 Appendix: Technical data

Device	
Technical data	TBPN-L1-FDIO1-2IOL
Ident no.	6814053
YoC	2016
Interfaces	
PROFINET	2 x M12, 4-pin, D coded
Service interface	Ethernet
Power supply	
V1 (incl. electronics supply)	24 VDC
V2	24 VDC, only through connected
Permissible range	20.4...28.8 VDC
Isolation voltages	≥ 500 VAC
Times	
Internal delay time (for calculating the Watchdog time)	10 ms
Reaction times	see „6.3 Safety characteristic data“ on p. 9
Safety inputs for potential free contacts	
Loop resistance	<150 Ω
Max. cable length	max. 1 μF at 150 Ω limited by line capacity
Test pulse typ.	0.6 ms
Test pulse max.	0.8 ms
Interval between 2 test pulses	900 ms (for static inputs)
Safety inputs for OSSD	
Signal voltage, low level	EN 61131-2, type 1 (< 5 V; < 0,5 mA)
Signal voltage, high level	EN 61131-2, type 1 (> 15 V; > 2 mA)
Max. OSSD supply per channel	2 A
Max. tolerated test pulse width	1 ms
Min. interval between 2 test pulses	12 ms at 1 ms test pulse width 8.5 ms at 0.5 ms test pulse width 7.5 ms at 0.2 ms test pulse width
Safety outputs	
Suitable for inputs according to EN 61131-2, type 1	
Output level in OFF-state	< 5 V
Output current in OFF-state	< 1 mA
Test pulse resistive load, max.	0.5 ms
Test pulse, max.	1.25 ms
Interval between 2 test pulses, typical	500 ms
Interval between 2 test pulses, min.	250 ms
Max. output current	2 A (resistive)

Max. total current for device

9 A, derating curve:

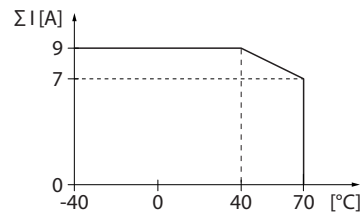

Max. output current

2 A, (DC-load) derating curve:

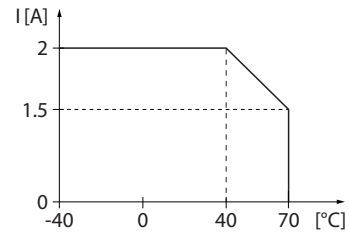

The user has to provide an additional overcurrent protection on site.

General Information

Max. cable length

- Ethernet	100 m (per segment)
- Sensor/actuator	30 m

Operating/storage temperature -40 °C to +70 °C (-40 to + 158 °F)

Protection class IP65/IP67/IP69K

Housing material Fiber-glass reinforced Polyamide (PA6-GF30)

Window material Lexan

Tests

Vibration test according to EN 60068-2-6, IEC 68-2-47, acceleration up to 20 g

Drop and topple according to IEC 60068-2-31/IEC 60068-2-32 1

Shock test according to EN 60068-2-27

Electro-magnetic compatibility according to EN 61131-2/EN 61326-3-1

14 Appendix: Declaration of Conformity

EG Konformitätserklärung Nr. 5126M

EC Declaration of Conformity No.: / Déclaration CE de conformité n° / Declaración CE de conformidad n.º / Dichiarazione CE di conformità N. / deklaracji zgodności WE nr:

TURCK

Wir/We/Nous/Nosotros/Noi/My

HANS TURCK GMBH & CO KG
WITZLEBENSTR. 7
D – 45472 MÜLHEIM A.D. RUHR

erklären in alleiniger Verantwortung, dass die Produkte

declare under our sole responsibility that the products / déclarons sous notre seule responsabilité que les produits / declaramos bajo nuestra propia responsabilidad que los productos / dichiariamo sotto la nostra esclusiva responsabilità, che I / deklaruje z pełną odpowiedzialnością, że produkty

Safety Block I/O Modul

TBPN-L1-FDIO1-2IOL

Safety block I/O Module / Modules de sécurité
E/S / Módulos de E/S de bloque de seguridad /
Moduli I/O di sicurezza / Kompaktowe moduły
bezpieczeństwa I/O

auf die sich die Erklärung bezieht, den Anforderungen der folgenden EU-Richtlinien durch Einhaltung der folgenden Normen genügen:

to which this declaration relates are in conformity with the requirements of the following EU directives by compliance with the following standards: / concernés par la présente déclaration répondent aux exigences des directives européennes suivantes conformément aux normes suivantes: / a los que hace referencia esta declaración cumplen los requisitos de las siguientes directivas de la UE ya que son conformes a las siguientes normas: / cui la presente dichiarazione fa riferimento, soddisfano i requisiti delle seguenti direttive UE in conformità alle seguenti norme: / do których odnosi się ta deklaracja, spełniają wymagania następujących dyrektyw UE poprzez zgodność z następującymi normami

EMV-Richtlinie / EMC Directive / 2014 / 30 / EU 26/2/2014
Directive EMC / Directiva CEM /
Direttiva EMC (compatibilità elettromagnetica) /
Dyrektywa EMC

EN 61000-6-2:2005 EN 61000-6-4:2007 + A1:2011 EN 61131-2:2007

Maschinenrichtlinie / Machinery directive / 2006 / 42 / EC 17/5/2006
Directive machines / Directiva sobre máquinas /
Direttiva macchine / Dyrektywa Maszynowa

EN ISO 13849-1:2015 EN ISO 13849-2:2012 EN 62061:2005/A1:2013/A2:2015

Weitere Normen, Bemerkungen

Additional standards, remarks / Autres normes, remarques / Otras normas, observaciones / Norme aggiuntive, osservazioni / Inne standardy, komentarze

EN 61326-3-1:2008
EN 61508-1...7:2010

Dokumentationsbevollmächtigter:

Authorized representative for documentation: / Représentant pour la documentation: / Rappresentante per la documentazione: / Representante para la documentación: / upoważnionego reprezentatywnie dla dokumentacji:

Dr. M. Linde
Witzlebenstr. 7
45472 Mülheim a. d. Ruhr

Nummer der EG-Baumusterprüfbescheinigung /
Number of EC Type Examination Certificate / Nom du certificat d'examen
de type CE / Número del certificado de examen CE de tipo / Numero del
certificato di esame CE del tipo / numer świadectwa badania typu WE

44 205 16 045401

Benannte Stelle /

Notified body / Organisme notifié / Organismo notificado / Organismo
notificato / Jednostka notyfikowana

0044
TÜV NORD CERT GmbH
Langemarckstraße 20
45151 Essen, Germany

Mülheim, 29.06.2016

i.V. Dr. M. Linde, Leiter Zulassungen / Manager Approvals / Responsable des autorisations / Director de aprobaciones / Direttore Omologazioni / Kierownik Name, Funktion und Unterschrift des Befugten / Name, function and signature of authorized person / Nom, fonction et signature de la personne autorisée / Nombre, cargo y firma del autorizado / Nome e funzione della persona autorizzata / Nazwisko, stanowisko i podpis osoby upoważnionej

Ort und Datum der Ausstellung /
Place and date of issue / Lieu et date
d'émission / Lugar y fecha de expedición /
Luogo e data del rilascio / Miejsce i data
wydania

TURCK

28 subsidiaries and over
60 representations worldwide!

D301391 | 2018/01



www.turck.com