

# Isolating switching amplifier 4-channel IMX18-DI03-4S-4T1R-SPR/24VDC/CC

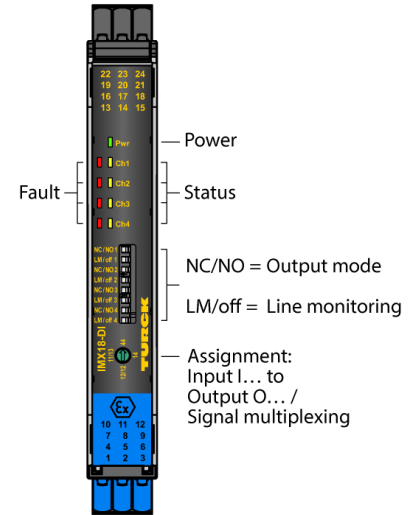
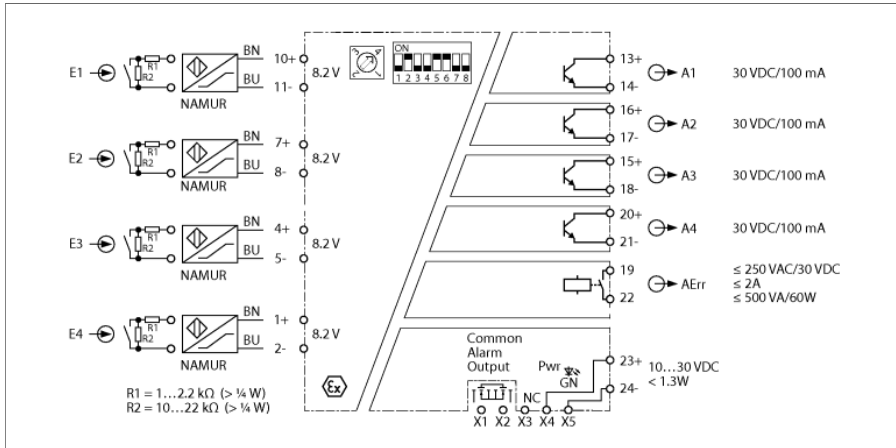

The IMX18-DI03-... isolating switching amplifiers are equipped with intrinsically safe input circuits and transfer binary signals from the explosion-hazardous area to the non-explosion-hazardous area. Sensors according to EN 60947-5-6 (NAMUR) or potential-free contacts can be connected to the devices. The devices are also suitable for operation in Zone 2.

The IMX18-DI03-4S-4T1R-SPR/24VDC/CC isolating switching amplifier has a 4-channel design. The device complies with the requirements of NE21. During transmission, the signals of the connected sensors and mechanical contacts are galvanically isolated. The output circuits are each equipped with a potential-free and short-circuit-proof transistor output (NO/NC configurable). The input signals are interpreted as low or high signals depending on the input level, and are output as a corresponding output signal. A separate relay output (NO) for collective fault signals is also provided. Via the Power-Bridge connection, the device can be supplied and a collective fault signal can be transmitted.

The devices are configured via DIP and rotary coding switches on the front. The following operating modes are possible:

- 4-channel: Each input (E1, E2, E3, E4) is assigned an output (A1, A2, A3, A4)
- 4-way splitter: Input E1 is assigned output A1, A2, A3 and A4
- 2 × 2-way splitter: Input E1 is assigned output A1 and A2; input E3 is assigned output A3 and A4
- 1-channel + 3-way splitter: Input E1 is assigned output A1; input E2 is assigned output A2, A3 and A4

In addition, the input circuit monitoring for wire break and short circuit (on/off) and the output mode of the output circuits (NO/NC) can be configured for each channel. When using mechanical contacts, either line monitoring must be switched off or the contact must be wired with resistors (see wiring diagram).

The devices have a green power LED (Pwr). Each channel has a yellow status LED for the output and a red status LED for the input. A fault in the input circuit causes the red LED to flash according to NE44.

In the event of a fault (wire break or short circuit), the assigned outputs switch to the LOW level and the relay output for collective fault signals is activated. In addition, an error message is output via the Power-Bridge connection.

The device can be used in safety circuits up to SIL 2 (high and low demand according to IEC 61508) (hardware fault tolerance HFT = 0).

The device is equipped with removable spring-type terminals.

- 4-channel
- 4 transistor outputs (potential free)
- Separate relay output for collective fault signals (NO)
- Configuration via rotary and DIP switches
- 4-channel operation or signal multiplexing (switchable)
- Adjustable output mode (NO/NC)
- Input circuits monitored for wire break/short circuit (can be switched ON/OFF)
- Complete galvanic isolation
- Input reverse-polarity protected
- Removable spring-type terminals
- Power-Bridge (connector incl. in delivery)
- ATEX, IECEx
- Use in Zone 2
- SIL 2

ID	100030010
Nominal voltage	24 VDC (SELV/PELV)
Operating voltage $U_o$	10...30 VDC
Power consumption	≤ 1.3 W
Power dissipation, typical	≤ 1.04 W

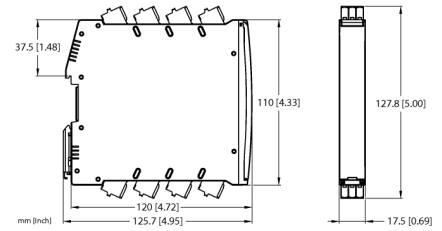

<b>NAMUR input</b>	
NAMUR	EN 60947-5-6
Input circuit monitoring	on/off switchable
No-load voltage	8.2 VDC
Short-circuit current	8.2 mA
Input resistance	1 kΩ
Cable resistance	≤ 50 Ω
Switch-on threshold	1.75 mA
Switch-off threshold	1.55 mA
Wire breakage threshold	≤ 0.06 mA
Short-circuit threshold	≥ 6.4 mA

<b>Output circuits</b>	
Output circuits (digital)	1 x relay (NO)
Output switching voltage relay	≤ 30 VDC / ≤ 250 VAC
Switching current per output	≤ 2 A
Switching capacity per output	≤ 500 VA/60 W
Switching frequency	≤ 15 Hz
Load type	Resistive load

<b>Semiconductor output circuits</b>	
Output circuits (digital)	4 x transistor (potential-free, short-circuit proof)
Switching voltage	≤ 30 VDC
Switching current per output	≤ 0.1 A
Switching frequency	≤ 10000 Hz
Voltage drop	≤ 2.5 V
Power-Bridge common alarm output	MOSFET, $U_{max} = 30 V$ , $I_{max} = 100 mA$

<b>Galvanic isolation</b>	
Test voltage	2.5 kV RMS
Output to supply	100 V RMS acc. to EN 50178 and EN 61010-1
Output to output	100 V RMS acc. to EN 50178 and EN 61010-1
Input to supply	375 V peak value acc. to EN 60079-11
Input to output	375 V peak value acc. to EN 60079-11

<b>Important note</b>	The values provided below indicate the relevant markings associated with the product's Ex certificates.
Ex approval acc. to conformity certificate	TÜV 14 ATEX 147004 X
Application area	II (1) G, II (1) D
Ignition protection category	[Ex ia Ga] IIC; [Ex ia Da] IIIC
Application area	II 3 (1) G
Ignition protection type	Ex nA [ia Ga] IIC T4 Gc
<b>Important note</b>	If the device is used in applications to achieve functional safety according to IEC 61508, the safety manual must be used. Information in the data sheet are not valid for functional safety.
Use in SIL safety circuits	SIL 2 acc. to IEC 61508

Displays/Operating elements	
Operational readiness	Green
Switching state	Yellow
Error indication	red

Mechanical data	
Protection class	IP20
Flammability class acc. to UL 94	V-0
Ambient temperature	-25...+70 °C
Storage temperature	-40...+80 °C
Dimensions	120 x 17.5 x 128 mm
Weight	211 g
Mounting instructions	DIN rail (NS35)
Housing material	Plastic, Polycarbonate/ABS
Electrical connection	Removable spring-type terminals, 3-pin
Connection variant	Power bridge with collective fault signal
Terminal cross-section	2.5 mm <sup>2</sup>

Environmental conditions	
Operating height	Up to 2000 m above sea level
Pollution degree	II
Surge/Overvoltage category	II (EN 61010-1)
Standards used	
Voltage resistance and insulation	
	EN 50178
	EN 61010-1
	EN 50155
	GL VI-7-2
Shock	
	EN 61373 class B
	EN 50155
	GL VI-7-2
	EN 60068-2-6
	EN 60068-2-27
Temperature	
	EN 60068-2-1 Ad
	EN 50155
	GL VI-7-2
	EN 60068-2-2 Bd
	EN 60068-2-1
Air humidity	
	EN 60068-2-38
EMC	
	EN 50155
	GL VI-7-2
	NE21
	EN 61326-1
	EN 61326-3-1
	EN 61000-4-2
	EN 61000-4-3
	EN 61000-4-4
	EN 61000-4-5
	EN 61000-4-6
	EN 61000-4-11
	EN 61000-4-29
	EN 55011
	EN 55016
	EN 50121-3-2
	EN 61000-6-2

## Accessories

Type code	Ident-No.		Dimension drawing
IMX12-PS02-UI-UIR-PR/24VDC/CC	7580611	Power supply module power bridge; Collective fault signal via relay; Single and redundant power supply via terminals; Removable screw terminals	
IM-CC-3X2BU/2BK	6900475	Cage clamp terminals for IM modules (Ex-devices with 18 mm overall width); includes: 2 pcs. 3-pin blue terminals and 2 pcs. 3-pin black terminals.	
IM-CC-3X2BK/2BK	7541218	Cage clamp terminals for IM modules ( Ex-devices with 18 mm overall width); includes: 4 pcs. of 3-pin black terminals	
WM1 WIDER-STANDSMODUL	0912101	The resistor module WM1 meets the requirements for line monitoring between a mechanical contact and a TURCK signal processor. The input circuit of the signal processor is designed for sensors acc. to EN60947-5-6 (NAMUR) and equipped with a wire-break and short-circuit monitoring function.	