

RI-10SA1R-2B600-H1151

Incremental Shaft Encoder

Industrial Line

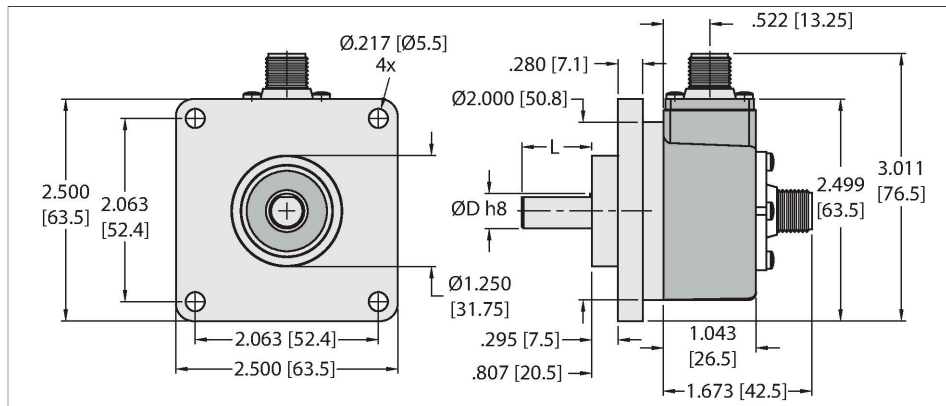

Features

- Square flange, 63.5mm
- Solid shaft, Ø 3/8" x 5/8"
- Optical measuring principle
- Shaft material, stainless steel
- Protection class IP67 on housing and shaft side
- -40...+85 °C
- Max. 6000 rpm (continuous operation 3000 rpm)
- 5...30 VDC
- Male connector, M12 x 1 , 5-pole
- Push-pull, with inverted signals
- Pulse frequency max. 300 kHz
- 600 pulses per revolution

Technical data

Type	RI-10SA1R-2B600-H1151
ID	100030528
Measuring principle	Optical
General data	
Max. rotational speed	6000 rpm
Moment of inertia of the rotor	$1.8 \times 10^{-6} \text{ kgm}^2$
Starting torque	< 0.05 Nm
Output type	Incremental
Resolution incremental	600 ppr
Electrical data	
Operating voltage U_b	10...30 VDC
No-load current	$\leq 100 \text{ mA}$
Output current	$\leq 30 \text{ mA}$
Short-circuit protection	yes
Wire break/reverse polarity protection	yes
Pulse frequency max.	300 kHz
Signal level high	min. $U_b - 1 \text{ V}$
Signal level low	max. 0.5 V
Output function	5-wire, Push-Pull/HTL, with inverted signals
Mechanical data	
Flange type	Synchro flange
Flange diameter	Ø 50.8 mm
Shaft Type	Solid shaft

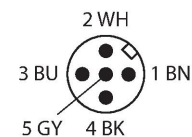
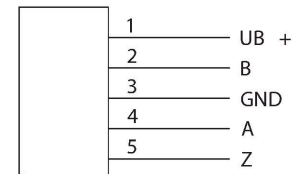

Technical data

Shaft diameter D	0.375 in
Shaft length (L)	0.625 in
Shaft material	Stainless steel
Housing material	Die-cast zinc
Electrical connection	M12 × 1
	5-pin
Axial shaft load	50 N
Radial shaft load	100 N
Environmental conditions	
Ambient temperature	-40...+85 °C
Vibration resistance (EN 60068-2-6)	300 m/s ² , 10...2000 Hz
Shock resistance (EN 60068-2-27)	3000 m/s ² , 6 ms
Protection class	IP67
Protection class shaft	IP67

Accessories

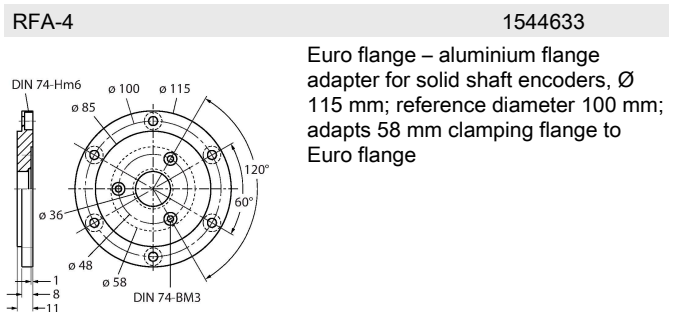
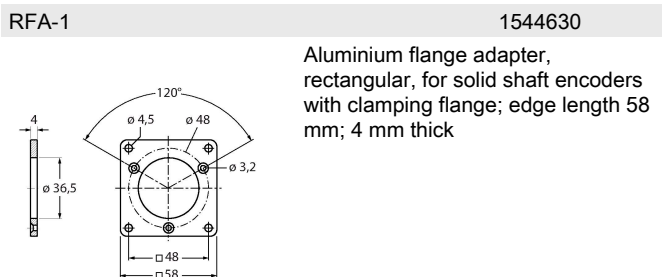
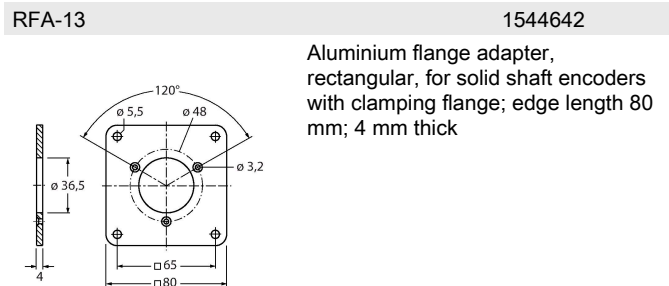
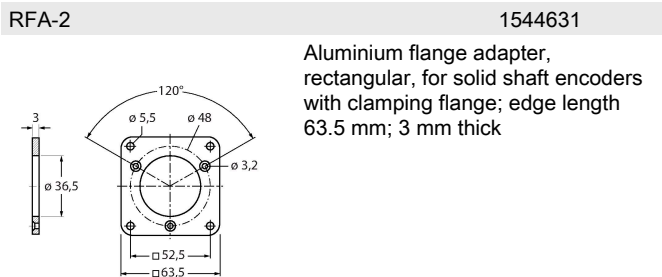

RFA-6 1544635

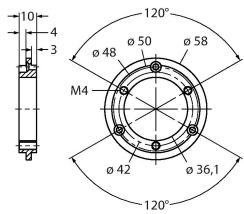

Aluminium flange adapter for solid shaft encoders with clamping flange, Ø 58 mm; adapts clamping flange to synchro flange

RFA-7 1544636

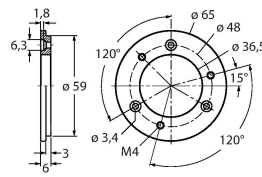

Aluminium flange adapter for solid shaft encoders, Ø 65 mm; adapts to Ø 65 mm flange and 48 mm reference diameter

RFA-8 1544637

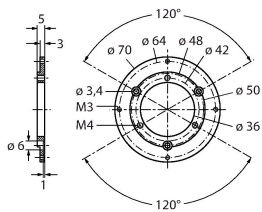

Aluminium flange adapter for solid shaft encoders with clamping flange, Ø 70 mm; thickness 4 mm, adapts to Ø 70 mm flange

RFA-9 1544638

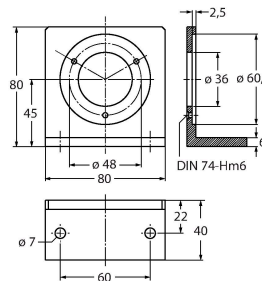

Aluminium angle flange for solid shaft encoders with Ø 58 mm clamping flange

RFA-11 1544640

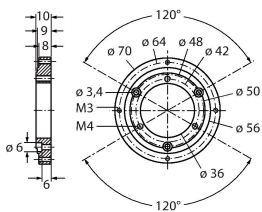

Aluminium flange adapter for solid shaft encoders with clamping flange, Ø 70 mm; thickness 10 mm, adapts to Ø 70 mm flange

RFA-12 1544641

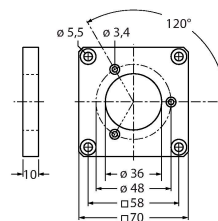

Aluminium flange adapter, rectangular, for solid shaft encoders with clamping flange; edge length 70 mm; 10 mm thick