

B2N85H-Q20L60-2LU3/S97

Inclinometer – With Increased Temperature Range

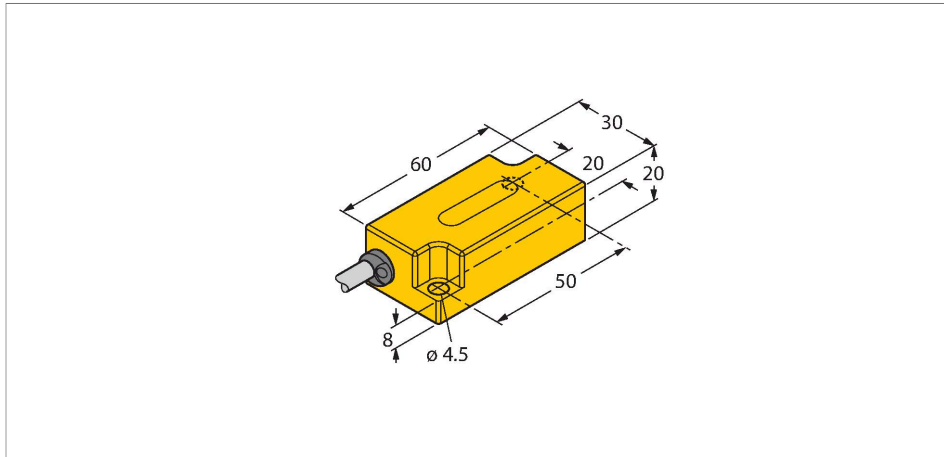

Features

- Plastic, PC
- Zero point calibration +/- 15°
- Two analog outputs
- Cable connection

Wiring diagram

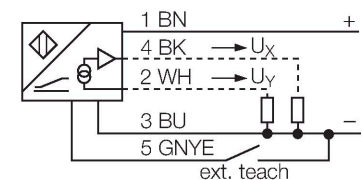

Technical data

Type	B2N85H-Q20L60-2LU3/S97
ID	1534040
Measuring principle	Acceleration
General data	
Measuring range	-85...85 °
Measuring range x-axis	-85...85 °
Measuring range y-axis	-85...85 °
Number of measuring axes	2
Repeatability	≤ 0.2 % of measuring range A - B
Linearity deviation	≤ 1 %
Temperature drift	≤ ± 0.02 %/K for temperature range between -40 °C and +85 °C
Resolution	≤ 0.14 °
Electrical data	
Operating voltage	10...30 VDC
Isolation test voltage	≤ 0.5 kV
Short-circuit protection	yes
Wire breakage/Reverse polarity protection	no / yes
Surge protection	-48...48 VDC [U _{b,max.}]
Output function	4-wire, Analog output
Voltage output	0.1...4.9 V
Load resistance voltage output	≥ 40 kΩ
Response time	0.1 s

Functional principle

Inclination is determined by a wear-free semiconducting sensor element.

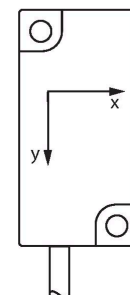
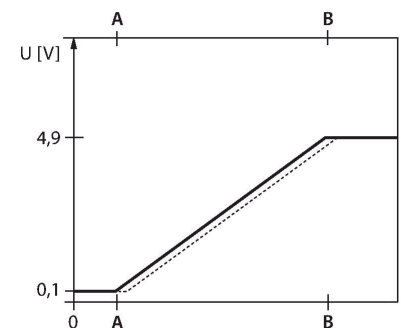
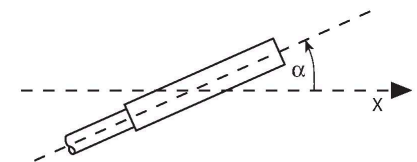

Technical data

time for the output signal to achieve 90% of full scale if the angle changes from -85° to +85°

Current consumption	50 mA
Mechanical data	
Design	Rectangular, Q20L60
Dimensions	60 x 30 x 20 mm
Housing material	Plastic, PC
Active area material	PBT-GF20-V0
Electrical connection	Cable
Cable quality	Ø 5.5 mm, Lif32Y32Y, TPE, 2 m
	Low temp. flexible and E-chain capable
Core cross-section	5 x 0.34 mm ²
Environmental conditions	
Ambient temperature	-40...+70 °C
Vibration resistance	55 Hz (1 mm)
Shock resistance	30 g (11 ms)
Protection class	IP68 IP69K
MTTF	203 years

Mounting instructions

Mounting instructions/Description

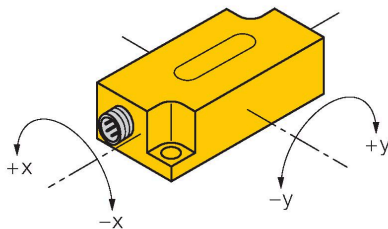

Width active area B 30 mm

Teaching

The zero point can be adjusted with teach adapter TX1-Q20L60.
 Teach-GND is pressed for approx. 1 s to do this. The outputs are switched to 5 V as confirmation.
 Teach-GND is pressed for 6 s to reset the axis zero points. The outputs are switched to 0 V as confirmation.
 Once the teach button is released, the sensor returns to normal operation.

Accessories

SG-Q20L60

6901100

Protective housing for Q20L60
inclinometers for protecting against
mechanical impact; material:
Stainless steel

