

B1N360V-Q20L60-2UP6X3-H1151/3GD

Inclinometer – With two Programmable Switching Points

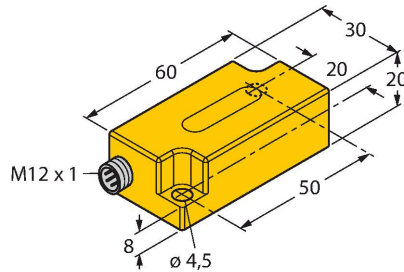

Features

- Rectangular, height 20 mm
- Plastic, PC
- Indication of operating voltage and switching state
- Two programmable switching outputs
- Switchpoints selectable in a range between 0° and 360°
- DC 4-wire, 10...30 VDC
- M12 x 1 male connector
- ATEX category II 3 G, Ex zone 2
- ATEX category II 3 D, Ex zone 22

Wiring diagram

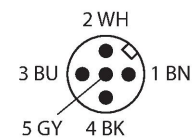
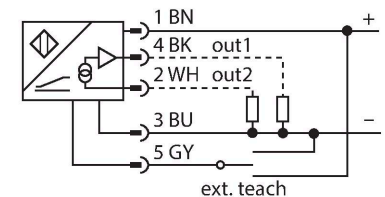

Technical data

Type	B1N360V-Q20L60-2UP6X3-H1151/3GD
ID	1534112
Measuring principle	Acceleration
General data	
Measuring range	0...360 °
Number of measuring axes	1
Mounting conditions	Vertical
Repeat accuracy	≤ 0.2 % of full scale
Absolute accuracy	± 0.5 ° At 25 °C
Temperature coefficient typical	0.03 °/K
Resolution	≤ 0.14 °
Electrical data	
Operating voltage	10...30 VDC
Residual ripple	≤ 10 % U _{ss}
Residual current	≤ 0.1 mA
Isolation test voltage	≤ 0.5 kV
Output current	≤ 500 mA
Response delay	500 ms
Dropout delay	350 ms
Short-circuit protection	yes / Thermal
Wire breakage/Reverse polarity protection	yes / Complete
Output function	5-pin, NO/NC, 2 × PNP
	Surge protection from +U _b to (U _b - 40V)
Current consumption	35 mA

Functional principle

Inclination is determined by a wear-free semiconducting sensor element.

Technical data

Approval acc. to	ATEX declaration of conformity TURCK Ex-12003H X
Device marking	Ex II 3 G Ex nA IIC T5 Gc/II 3 D Ex tc IIIC T85°C Dc
Mechanical data	
Design	Rectangular, Q20L60
Dimensions	60 x 30 x 20 mm
Housing material	Plastic, PC
Electrical connection	Connector, M12 × 1
Environmental conditions	
Ambient temperature	-30...+70 °C
	For explosion hazardous areas see instruction leaflet
Vibration resistance	55 Hz (1 mm)
Shock resistance	30 g (11 ms)
Protection class	IP68 IP69K
MTTF	399 years acc. to SN 29500 (Ed. 99) 40 °C
Power-on indication	LED, Green
Switching state	2 × LEDs, Yellow
Included in delivery	Security clip SC-M12/3GD

Mounting instructions

Mounting instructions/Description

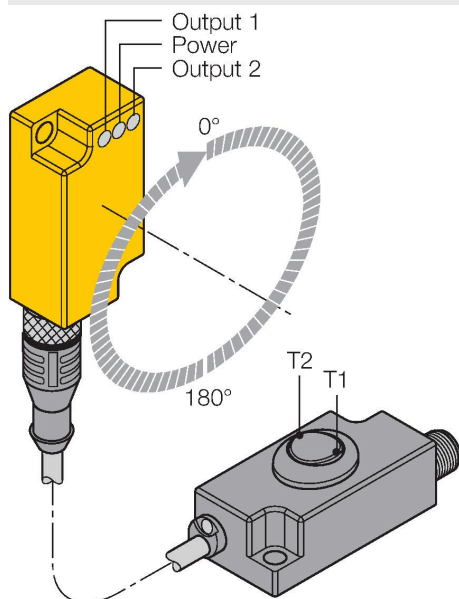

The switchpoints are set with the TX1-Q20L60 teach adapter

By actuating the toggle switch T1 (OUT 1), a bridge is formed between GND and pin 5.
By actuating the toggle switch T2 (OUT 2), a bridge is formed between UB and pin 5.
The switch-on and off points are freely selectable within 360° degrees.

You can teach-in the switching points either clockwise or counter-clockwise.

Before programming the wanted switch-on and off points, move the sensor in start position. For details on programming, please see next page. Should you wish to set the switch-off point yourself, the sensor must also be positioned at this point. The sensor must be installed in vertical position.

A further programming method has already a preset range of 180°. Here, only the switch-on point must be set.

Accessories

GUARD-Q20L60

A9684

Protective housing for Q20L60
inclinometers for protecting against
mechanical impact; material:
Stainless steel

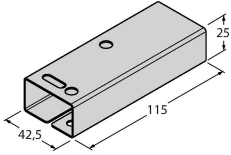

Instructions for use

Switchpoint adjustable as NO contact counter-clockwise or as NC contact clockwise

Press T1 (T2) for 5 s

Power LED flashes

Place the sensor in the wanted start position

Press T1 (T2) for 1 s to set the switch-on point

Power LED and Output 1 (2) LED flash

Place the sensor in the wanted end position

Press T1 (T2) for 3 s to set the switch-off point

Power LED and Output 1 (2) LED flash for 3 s then turn steady

Teach process completed, sensor ready for operation.

Switchpoint adjustable as NO contact clockwise or as NC contact counter-clockwise

Press T1 (T2) for 5 s

Power LED flashes

Place the sensor in the wanted start position

Press T1 (T2) for 3 s to set the switch-on point

Power LED and Output 1 (2) LED flash fast

Place the sensor in the wanted end position

Press T1 (T2) for 1 s to set the switch-off point

Power LED and Output 1 (2) LED flash for 3 s then turn steady

Teach process completed, sensor ready for operation.

Switchpoint adjustable as NO contact counter-clockwise or as NC contact clockwise (180° default setting)

Press T1 (T2) for 5 s

Power LED flashes

Place the sensor in the wanted start position

Press T1 (T2) for 1 s to set the switch-on point

Power LED and Output 1 (2) LED flash

Press T1 (T2) for 1 s to set the travel path 180 ° and the hysteresis 1 °

Power LED and Output 1 (2) LED flash for 3 s then turn steady

Teach process completed, sensor ready for operation.

Switchpoint adjustable as NO contact clockwise or as NC contact counter-clockwise (180° default setting)

Press T1 (T2) for 5 s

Power LED flashes

Place the sensor in the wanted start position

Press T1 (T2) for 3 s to set the switch-on point

Power LED and Output 1 (2) LED flash fast

Press T1 (T2) for 3 s to set the travel path 180 ° and the hysteresis 1 °

Power LED and Output 1 (2) LED flash for 3 s then turn steady

Teach process completed, sensor ready for operation.

T1 = Switching output 1; T2 = Switching output 2

Default settings:

Hysteresis 1°

Intended use

This device fulfills the directive 2014/34/EC and is suited for use in explosion hazardous areas according to EN60079-0:2009, EN60079-15:2010 and EN60079-31:2009. In order to ensure correct operation to the intended purpose it is required to observe the national regulations and directives.

For use in explosion hazardous areas conform to classification

II 3 G and II 3 D (Group II, Category 3 G, electrical equipment for gaseous atmospheres and category 3 D, electrical equipment for dust atmospheres).

Marking (see device or technical data sheet)

Ex II 3 G Ex nA IIC T5 Gc acc. to EN 60079-0:2009 and EN 60079-15:2010 and Ex II 3 D Ex tc IIIC T85°C Dc acc. to EN 60079-0:2009 and EN 60079-31:2009

Local admissible ambient temperature

-30...+70 °C

Installation/Commissioning

These devices may only be installed, connected and operated by trained and qualified staff. Qualified staff must have knowledge of protection classes, directives and regulations concerning electrical equipment designed for use in explosion hazardous areas. Please verify that the classification and the marking on the device comply with the actual application conditions.

Installation and mounting instructions

Avoid static charging of cables and plastic devices. Please only clean the device with a damp cloth. Do not install the device in a dust flow and avoid build-up of dust deposits on the device. If the devices and the cable could be subject to mechanical damage, they must be protected accordingly. They must also be shielded against strong electro-magnetic fields. The pin configuration and the electrical specifications can be taken from the device marking or the technical data sheet. In order to avoid contamination of the device, please remove possible blanking plugs of the cable glands or connectors only shortly before inserting the cable or opening the cable socket.

Special conditions for safe operation

For devices with M12 connectors please use the supplied safety clip SC-M12/3GD. The safety clips SC-M12/3GD are not required when using the protective housing SG-Q20L60. Do not disconnect the plug-in connection or cable under voltage. Please attach a warning label permanently in an appropriate fashion in close proximity to the plug-in connection with the following inscription: Nicht unter Spannung trennen / Do not separate when energized. The device must be protected against any kind of mechanical damage and degrading UV-radiation. On selecting the approval-relevant accessories, always ensure that they are installed conform to the application. Load voltage and operating voltage of this equipment must be supplied from power supplies with safe isolation (IEC 30 364/UL508), to ensure that the rated voltage of the equipment ($24 \text{ VDC} + 20\% = 28.8 \text{ VDC}$) is never exceeded by more than 40%.

Service/Maintenance

Repairs are not possible. The approval expires if the device is repaired or modified by a person other than the manufacturer. The most important data from the approval are listed.

Instructions for use

Switchpoint adjustable as NO contact counter-clockwise or as NC contact clockwise

Press T1 (T2) for 5 s

Power LED flashes

Place the sensor in the wanted start position

Press T1 (T2) for 1 s to set the switch-on point

Power LED and Output 1 (2) LED flash

Place the sensor in the wanted end position

Press T1 (T2) for 3 s to set the switch-off point

Power LED and Output 1 (2) LED flash for 3 s then turn steady

Teach process completed, sensor ready for operation.

Switchpoint adjustable as NO contact clockwise or as NC contact counter-clockwise

Press T1 (T2) for 5 s

Power LED flashes

Place the sensor in the wanted start position
Press T1 (T2) for 3 s to set the switch-on point
Power LED and Output 1 (2) LED flash fast
Place the sensor in the wanted end position
Press T1 (T2) for 1 s to set the switch-off point
Power LED and Output 1 (2) LED flash for 3 s then turn steady
Teach process completed, sensor ready for operation.

Switchpoint adjustable as NO contact counter-clockwise or as NC contact clockwise (180° default setting)
Press T1 (T2) for 5 s
Power LED flashes
Place the sensor in the wanted start position
Press T1 (T2) for 1 s to set the switch-on point
Power LED and Output 1 (2) LED flash
Press T1 (T2) for 1 s to set the travel path 180 ° and the hysteresis 1 °
Power LED and Output 1 (2) LED flash for 3 s then turn steady
Teach process completed, sensor ready for operation.

Switchpoint adjustable as NO contact clockwise or as NC contact counter-clockwise (180° default setting)
Press T1 (T2) for 5 s
Power LED flashes
Place the sensor in the wanted start position
Press T1 (T2) for 3 s to set the switch-on point
Power LED and Output 1 (2) LED flash fast
Press T1 (T2) for 3 s to set the travel path 180 ° and the hysteresis 1 °
Power LED and Output 1 (2) LED flash for 3 s then turn steady
Teach process completed, sensor ready for operation.

T1 = Switching output 1; T2 = Switching output 2

Default settings:

Hysteresis 1°