

RU100U-EMT18M-UP8X2-H1151

Ultrasonic Sensor – Diffuse Mode Sensor

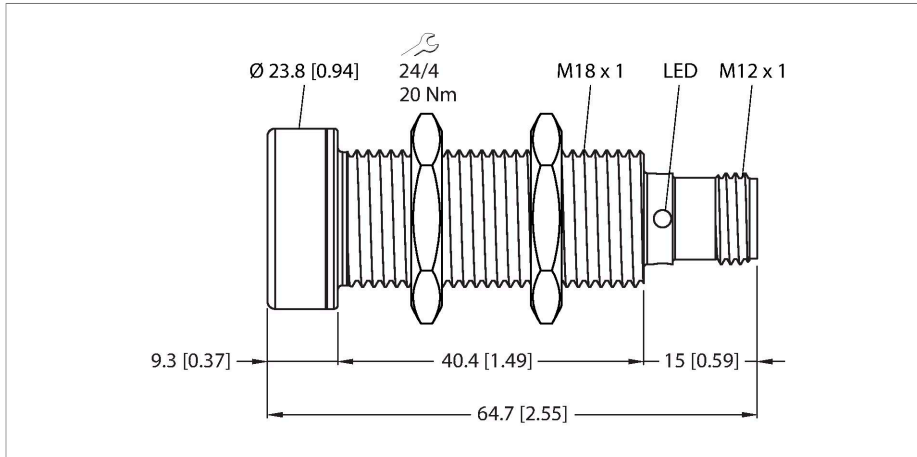

Technical data

| | |
|--------------------------------------|---------------------------|
| Type | RU100U-EMT18M-UP8X2-H1151 |
| ID | 1610115 |
| Ultrasonic data | |
| Function | Proximity |
| Range | 150...1000 mm |
| Resolution | 1 mm |
| Minimum switching range | 10 mm |
| Ultrasound frequency | 200 kHz |
| Repeat accuracy | ≤ 0.15 % of full scale |
| Temperature drift | ± 1.5 % of full scale |
| Linearity error | ≤ ± 0.5 % |
| Edge lengths of the nominal actuator | 100 mm |
| Approach speed | ≤ 8 m/s |
| Pass speed | ≤ 2 m/s |
| Electrical data | |
| Operating voltage U_s | 15...30 VDC |
| Residual ripple | 10 % U_s |
| DC rated operating current I_s | ≤ 150 mA |
| No-load current | ≤ 50 mA |
| Load resistance | ≤ 1000 Ω |
| Residual current | ≤ 0.1 mA |
| Response time typical | < 90 ms |
| Readiness delay | ≤ 300 ms |

Features

- Sonic transducer face with PTFE layer
- • Stainless steel front attachment
- Cylindrical housing M18, potted
- Connection via M12 × 1 male connector
- Temperature compensation
- Blind zone: 15 cm
- Range: 100 cm
- Resolution: 1 mm
- Aperture angle of sonic cone: ±16 °
- 1 × switching output, PNP
- Teachable settings
- NO/NC programmable

Wiring diagram

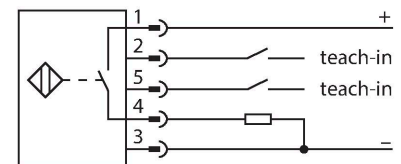

Functional principle

Ultrasonic sensors capture a multitude of objects contactlessly and wear-free with ultrasonic waves. It does not matter whether the object is transparent or opaque, metallic or non-metallic, firm, liquid or powdery. Even environmental conditions such as spray, dust or rain hardly affect their function. The sonic cone diagram indicates the detection range of the sensor. In accordance with standard EN 60947-5-2, quadratic targets in a range of sizes (20 × 20 mm, 100 × 100

Technical data

| | |
|---------------------------------------|--|
| Output function | NO/NC, PNP |
| Output 1 | Switching output |
| Switching frequency | ≤ 6.9 Hz |
| Hysteresis | ≤ 10 mm |
| Voltage drop at I _e | ≤ 2.5 V |
| Short-circuit protection | yes/Cyclic |
| Reverse polarity protection | yes |
| Wire breakage protection | yes |
| Setting option | Remote Teach |
| Mechanical data | |
| Design | Threaded barrel, M18 |
| Radiation direction | straight |
| Dimensions | Ø 18 x 63 mm |
| Housing material | Stainless steel, 1.4404 (AISI 316L), PTFE-coated |
| Max. tightening torque of housing nut | 20 Nm |
| Transducer material | Plastic, Epoxy resin and PU foam with PTFE coating |
| Electrical connection | Connector, M12 × 1, 5-wire |
| Ambient temperature | -5...+50 °C |
| Storage temperature | -40...+50 °C |
| Pressure resistance | 0.5...5 bar |
| Protection class | IP67 |
| Switching state | LED, Yellow |
| Object detected | LED, Green |
| Tests/approvals | |
| MTTF | 281 years acc. to SN 29500 (Ed. 99) 40 °C |
| Declaration of conformity EN ISO/IEC | EN 60947-5-2 |
| Vibration resistance | 20 g, 10...55 Hz, sine, 3 axes, 30 min/axis according to IEC 60068-2-6 |
| Shock test | 30 g, 11 ms, half sine, 3 axes according to IEC 60068-2-27 |
| Approvals | CE cULus |

mm) and a round rod with a diameter of 27 mm are used.
Important: The detection ranges for other targets may differ from those for standard targets due to the different reflection properties and geometries.

Sonic Cone

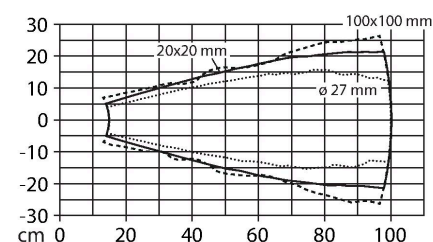

Mounting instructions

Mounting instructions/Description

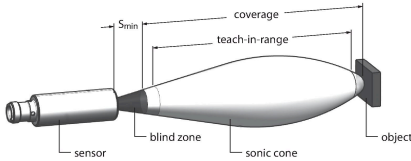

| | | | | |
|---|-----------|----|--|------|
| Single switching point: measure and save | GND > 2 s | OK | | 3 Hz |
| Invert logic | UB > 2 s | OK | | 2 Hz |

Setting the switching point

The ultrasonic sensor features a switching output with a teachable switching point. The green and yellow LEDs indicate whether the sensor has detected the object.

One switching point is taught. This must be within the detection range. In this operating mode the background is suppressed.

Easy-Teach

Connect the TX1-Q20L60 teach adapter between the sensor and connection cable. Place object at the end of the switching range. Press and hold button for at least 2 s against Gnd.

After a successful teach-in, the green LED flashes at 3 Hz and the sensor runs automatically in normal mode.

To invert the output function, press and hold the button against the Ub for 2...7s.

LED response

In standard operating mode, the two LEDs indicate the switching state of the sensor.

Green: Object within the detection range but not in switching range

Yellow: Object is within the switching range

Off: Object is outside the detection range or signal loss

Accessories

MW18

6945004

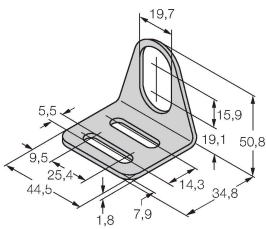

Mounting bracket for threaded barrel sensors; material: Stainless steel A2 1.4301 (AISI 304)

Wiring accessories

| Dimension drawing | Type | ID | |
|-------------------|---------------|---------|--|
| | RKC4.5T-2/TEL | 6625016 | |



Connection cable, M12 female connector, straight, 5-pin, cable length: 2 m, jacket material: PVC, black; cULus approval

| Dimension drawing | Type | ID | |
|-------------------|---------------|---------|---|
| | WKC4.5T-2/TEL | 6625028 | Connection cable, M12 female connector, angled, 5-pin, cable length: 2 m, jacket material: PVC, black; cULus approval |

Accessories

| Dimension drawing | Type | ID | |
|-------------------|------------|---------|---|
| | TX1-Q20L60 | 6967114 | Teach adapter for inductive encoders, linear position, angle, ultrasonic and capacitive sensors |