

BI1-EG04-AP6X Inductive Sensor

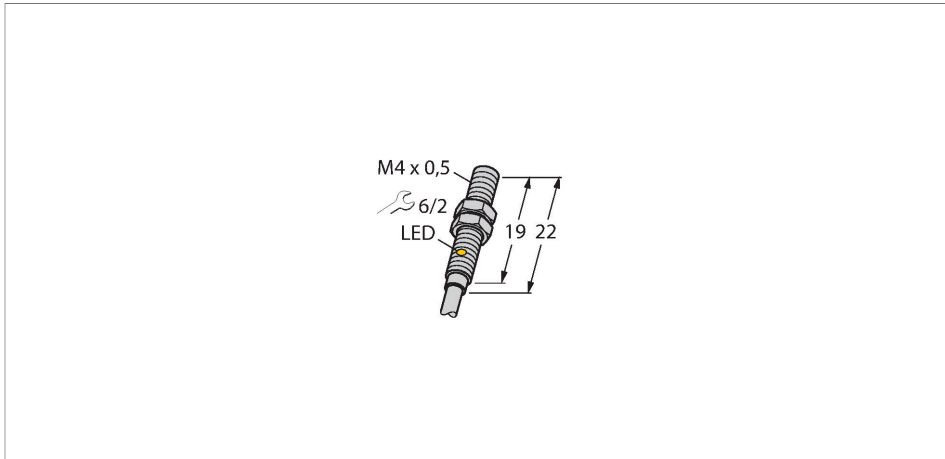

Technical data

Type	BI1-EG04-AP6X
ID	1619327
General data	
Rated switching distance	1 mm
Mounting conditions	Flush
Secured operating distance	$\leq (0.81 \times S_n)$ mm
Correction factors	St37 = 1; Al = 0.5; Cu=0.45; stainless steel = 0.8; Ms = 0.6
Repeat accuracy	≤ 2 % of full scale
Temperature drift	$\leq \pm 10$ %
Hysteresis	3...15 %
Electrical data	
Operating voltage	10...30 VDC
Residual ripple	≤ 20 % U_{ss}
DC rated operational current	≤ 100 mA
No-load current	10 mA
Residual current	≤ 0.1 mA
Isolation test voltage	≤ 0.5 kV
Short-circuit protection	yes / Cyclic
Voltage drop at I_o	≤ 2 V
Wire breakage/Reverse polarity protection	yes / Complete
Output function	3-wire, NO contact, PNP
Switching frequency	3 kHz

Features

- Threaded barrel, M4 × 0.5
- Stainless steel, 1.4305
- DC 3-wire, 10...30 VDC
- NO contact, PNP output
- Cable connection

Wiring diagram

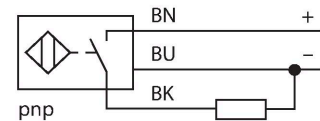

Functional principle

Inductive sensors detect metal objects contactless and wear-free. For this, they use a high-frequency electromagnetic AC field that interacts with the target. Inductive sensors generate this field via an RLC circuit with a ferrite coil.

BI1-EG04-AP6X | 11/07/2023 14-57 | technical changes reserved

Technical data

Mechanical data	
Design	Threaded barrel, M4 x 0.5
Dimensions	22 mm
Housing material	Stainless steel, 1.4427 SO
Active area material	Plastic, Polyester
Max. tightening torque of housing nut	0.8 Nm
Electrical connection	Cable
Cable quality	Ø 2.6 mm, LifY-11Y, PUR, 2 m
Core cross-section	3 x 0.055 mm ²
Environmental conditions	
Ambient temperature	-25...+70 °C
Vibration resistance	55 Hz (1 mm)
Shock resistance	30 g (11 ms)
Protection class	IP67
MTTF	2283 years acc. to SN 29500 (Ed. 99) 40 °C
Switching state	LED, Yellow, Flashes within the limits (>0.8 Sn)

Mounting instructions

Mounting instructions/Description

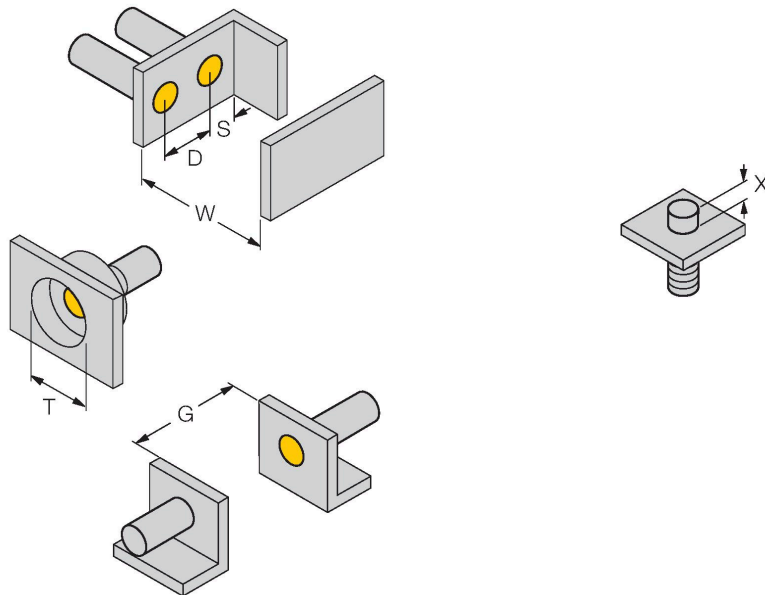

Distance D	2 x B
Distance W	3 x Sn
Distance T	3 x B
Distance S	1.5 x B
Distance G	9 x Sn
Diameter active area B	Ø 4 mm

The sensor can be flush-mounted in non-ferromagnetic material. When mounted in ferromagnetic material the distance X must be observed.

Distance X: 1.0 mm

B11-EG04-AP6X | 11/07/2023 14-57 | technical changes reserved