

RI-12H12T-2B64-H1181

Incremental Encoder

Industrial Line

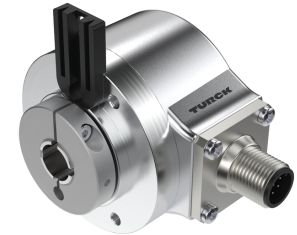
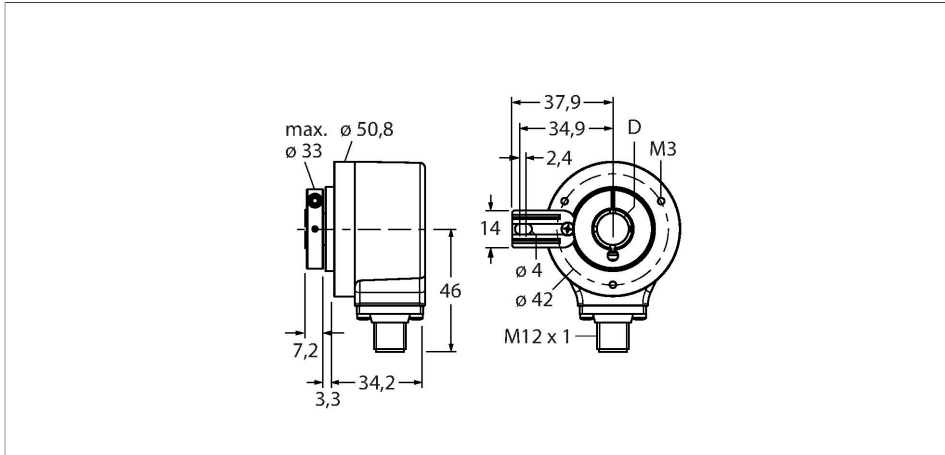

Technical data

Type	RI-12H12T-2B64-H1181
ID	200001027
Measuring principle	Optical
General data	
Max. rotational speed	6000 rpm
Moment of inertia of the rotor	6×10^{-6} kgm ²
Starting torque	< 0.05 Nm
Output type	Incremental
Resolution incremental	64 ppr
Electrical data	
Operating voltage U_b	10...30 VDC
No-load current	≤ 100 mA
Output current	≤ 30 mA
Short-circuit protection	yes
Wire break/reverse polarity protection	yes
Pulse frequency max.	300 kHz
Signal level high	min. $U_b - 1$ V
Signal level low	max. 0.5 V
Output function	Push-Pull/HTL, with inverted signals
Mechanical data	
Flange type	Flange with mounting element
Flange diameter	$\varnothing 50.8$ mm
Shaft Type	Hollow shaft

Features

- Flange with torque stop, $\varnothing 50.8$ mm
- Hollow shaft, $\varnothing 12$ mm
- Optical measuring principle
- Shaft material: stainless steel
- Protection class IP67 on housing and shaft side
- -40...+85 °C
- Max. 6000 rpm (continuous operation 3000 rpm)
- 10...30 VDC
- Male connector, M12 x 1, 8-pole
- Push-pull, with inverted signals
- Pulse frequency max. 300 kHz
- 64 pulses

Wiring diagram

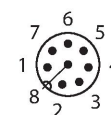
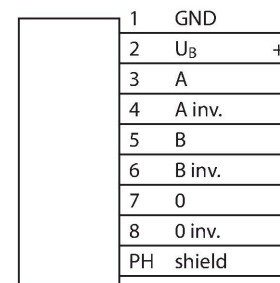

Technical data

Shaft diameter D (mm)	12
Shaft diameter D	0.472 in
Shaft material	Stainless steel
Housing material	Die-cast zinc
Electrical connection	Connector, M12 × 1
	8-pin
Axial shaft load	40 N
Radial shaft load	80 N
Environmental conditions	
Ambient temperature	-40...+85 °C
Vibration resistance (EN 60068-2-6)	300 m/s ² , 10...2000 Hz
Shock resistance (EN 60068-2-27)	3000 m/s ² , 6 ms
Protection class	IP67
Protection class shaft	IP67