

BIM-AKT-AD4X 7M W/KLA-3M

Magnetic Field Sensor – For Pneumatic Cylinders

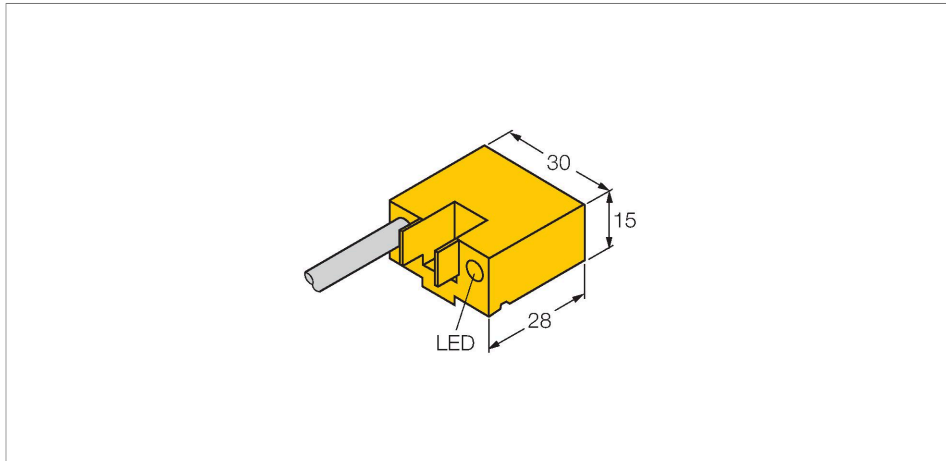

Features

- Rectangular, height 15mm
- Concentric active face
- Plastic, PA12-GF30
- Magnetic-inductive sensor
- DC 2-wire, 10...65 VDC
- NO contact
- Cable connection

Wiring diagram

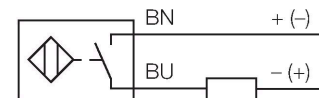

Technical data

Type	BIM-AKT-AD4X 7M W/KLA-3M
ID	4480099
General data	
Pass speed	≤ 3 m/s
Repeatability	≤ ± 0.1 mm
Temperature drift	≤ 0.1 mm
Hysteresis	≤ 1 mm
Electrical data	
Operating voltage	10...65 VDC
Residual ripple	≤ 10 % U _{ss}
DC rated operational current	≤ 100 mA
Residual current	≤ 0.8 mA
Isolation test voltage	≤ 0.5 kV
Short-circuit protection	yes / Cyclic
Voltage drop at I _o	≤ 4 V
Wire breakage/Reverse polarity protection	no / Complete
Output function	NO contact, 2-wire
Switching frequency	0.3 kHz
Mechanical data	
Design	Rectangular, AKT
Dimensions	28 x 30 x 15 mm
Housing material	Plastic, PA12-GF30
Active area material	Plastic, PA12-GF30
Electrical connection	Cable

Functional principle

Magnetic field sensors are activated by magnetic fields and are especially suited for piston position detection in pneumatic cylinders. Based on the fact that magnetic fields can permeate non-magnetizable metals, it is possible to detect a permanent magnet attached to the piston through the aluminium wall of the cylinder.

Technical data

Cable quality	Ø 5.2 mm, LifYY, PVC, 7 m
Core cross-section	2 x 0.34 mm ²
Environmental conditions	
Ambient temperature	-25...+70 °C
Vibration resistance	55 Hz (1 mm)
Shock resistance	30 g (11 ms)
Protection class	IP67
MTTF	2283 years acc. to SN 29500 (Ed. 99) 40 °C
Mounting on the following profiles	
Cylindrical design	#
Switching state	LED, Red
Included in delivery	KLA-3M

Accessories

KLA1

69700

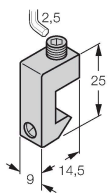

Mounting bracket for mounting magnetic field sensors on tie-rod cylinders; cylinder diameter 32... 50 mm; material: Anodized aluminum

KLA3

69702

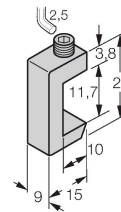

Mounting bracket for mounting magnetic field sensors on tie-rod cylinders; cylinder diameter 32... 63 mm; material: Stainless steel

KLA2

69701

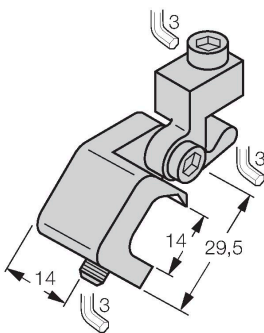

Mounting bracket for mounting magnetic field sensors on tie-rod cylinders; cylinder diameter 40... 125 mm; material: Aluminum