

# BI1-EG05-AN6X-0.2-RS4T

## Inductive Sensor

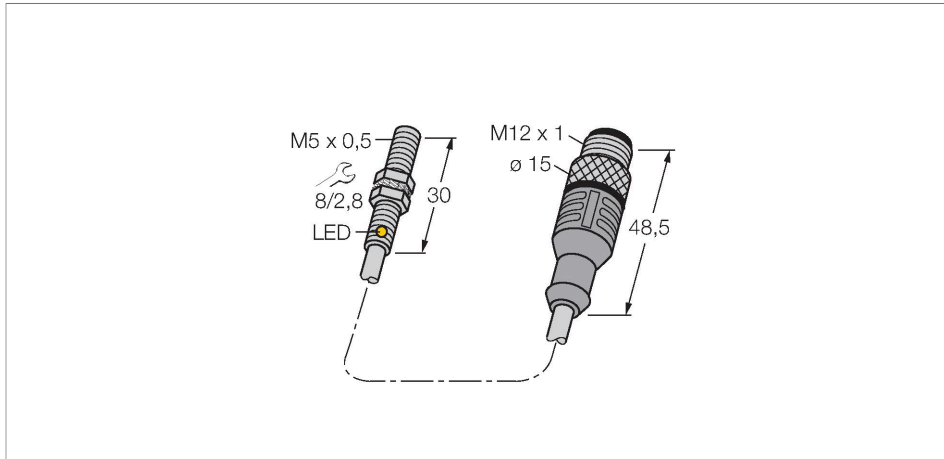

### Features

- Threaded barrel, M5 x 0.5
- Stainless steel, 1.4427 SO
- DC 3-wire, 10...30 VDC
- NO contact, NPN output
- Pigtail with M12 × 1 connector

### Wiring diagram

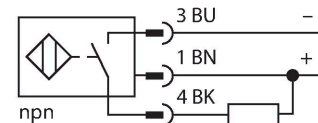

### Technical data

Type	BI1-EG05-AN6X-0.2-RS4T
ID	4609898
<b>General data</b>	
Rated switching distance	1 mm
Mounting conditions	Flush
Secured operating distance	$\leq (0.81 \times S_n)$ mm
Correction factors	St37 = 1; Al = 0.3; stainless steel = 0.7; Ms = 0.4
Repeat accuracy	$\leq 2$ % of full scale
Hysteresis	3...15 %
<b>Electrical data</b>	
Operating voltage	10...30 VDC
Residual ripple	$\leq 10$ % $U_{ss}$
DC rated operational current	$\leq 100$ mA
No-load current	15 mA
Residual current	$\leq 0.1$ mA
Isolation test voltage	$\leq 0.5$ kV
Short-circuit protection	yes / Cyclic
Voltage drop at $I_o$	$\leq 1.8$ V
Wire breakage/Reverse polarity protection	yes / Complete
Output function	3-wire, NO contact, NPN
Switching frequency	3 kHz
<b>Mechanical data</b>	
Design	Threaded barrel, M5 x 0.5

### Functional principle

Inductive sensors detect metal objects contactless and wear-free. For this, they use a high-frequency electromagnetic AC field that interacts with the target. Inductive sensors generate this field via an RLC circuit with a ferrite coil.

## Technical data

Dimensions	30 mm
Housing material	Stainless steel, 1.4427 SO
Active area material	Plastic, PA12
Material coupling nut	metal, CuZn, nickel-plated
Max. tightening torque of housing nut	5 Nm
Electrical connection	Cable with connector, M12 × 1
Cable quality	Ø 3 mm, Gray, Lif9Y-11Y, PUR, 0.2 m
	Suited for E-ChainSystems® acc. to manufacturers declaration H1063M
Core cross-section	3 x 0.14 mm <sup>2</sup>
<b>Environmental conditions</b>	
Ambient temperature	-25...+70 °C
Vibration resistance	55 Hz (1 mm)
Shock resistance	30 g (11 ms)
Protection class	IP67
MTTF	2283 years acc. to SN 29500 (Ed. 99) 40 °C
Switching state	LED, Yellow

## Mounting instructions

### Mounting instructions/Description

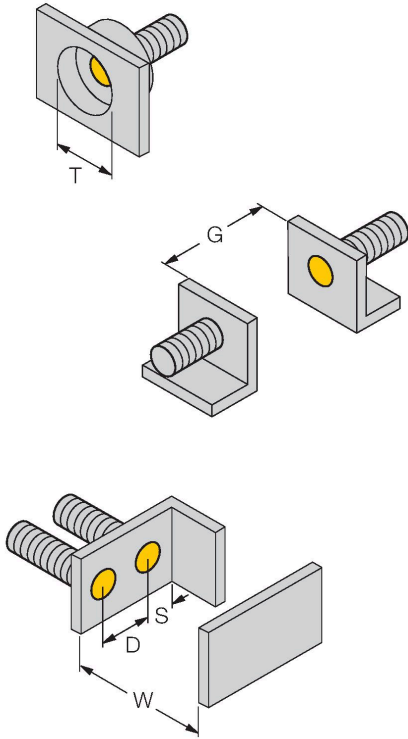

Distance D	$2 \times B$
------------	--------------

Distance W	$3 \times S_n$
------------	----------------

Distance T	$3 \times B$
------------	--------------

Distance S	$1.5 \times B$
------------	----------------

Distance G	$6 \times S_n$
------------	----------------

Diameter active area B	$\varnothing 5 \text{ mm}$
------------------------	----------------------------