

# BI8-Q10-VN6X2

## Inductive Sensor

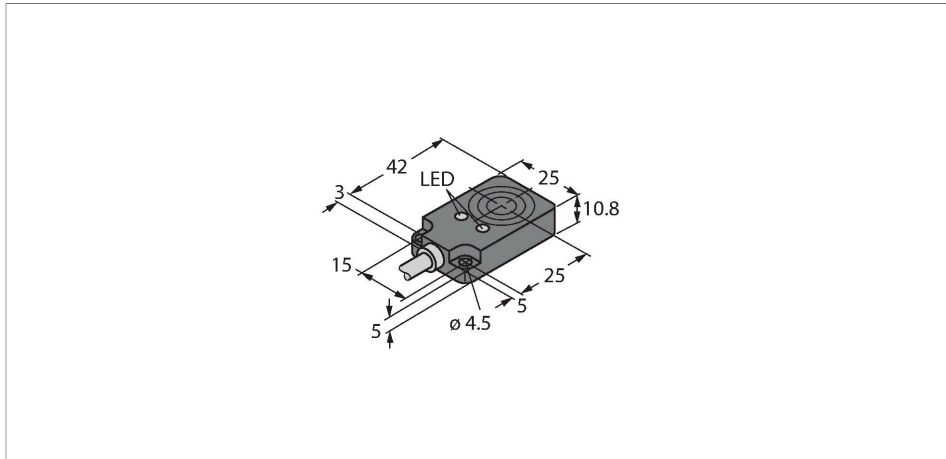

### Features

- Rectangular, height 10.8 mm
- Active face on top
- Plastic, PBT-GF30-V0
- DC 4-wire, 10...30 VDC
- Complementary, NPN output
- Cable connection

### Wiring diagram

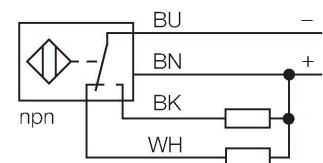

### Technical data

Type	BI8-Q10-VN6X2
ID	4616410
<b>General data</b>	
Rated switching distance	8 mm
Mounting conditions	Flush
Secured operating distance	$\leq (0.81 \times S_n)$ mm
Correction factors	St37 = 1; Al = 0.3; stainless steel = 0.7; Ms = 0.4
Repeat accuracy	$\leq 2$ % of full scale
Temperature drift	$\leq \pm 10$ %
Hysteresis	3...15 %
<b>Electrical data</b>	
Operating voltage	10...30 VDC
Residual ripple	$\leq 10$ % $U_{ss}$
DC rated operational current	$\leq 200$ mA
No-load current	15 mA
Residual current	$\leq 0.1$ mA
Isolation test voltage	$\leq 0.5$ kV
Short-circuit protection	yes / Cyclic
Voltage drop at $I_o$	$\leq 1.8$ V
Wire breakage/Reverse polarity protection	yes / Complete
Output function	4-wire, Complementary contact, NPN
Switching frequency	1 kHz

### Functional principle

Inductive sensors detect metal objects contactless and wear-free. For this, they use a high-frequency electromagnetic AC field that interacts with the target. Inductive sensors generate this field via an RLC circuit with a ferrite coil.

## Technical data

Mechanical data	
Design	Rectangular, Q10
Dimensions	42 x 25 x 10.8 mm
Housing material	Plastic, PBT-GF30-V0
Active area material	PBT-GF30-V0
Electrical connection	Cable
Cable quality	Ø 5.2 mm, LifYY, PVC, 2 m
Core cross-section	4 x 0.25 mm <sup>2</sup>
Environmental conditions	
Ambient temperature	-25...+70 °C
Vibration resistance	55 Hz (1 mm)
Shock resistance	30 g (11 ms)
Protection class	IP67
MTTF	2283 years acc. to SN 29500 (Ed. 99) 40 °C
Power-on indication	LED, Green
Switching state	LED, Yellow

## Mounting instructions

Mounting instructions/Description		
	Distance D	2 x B
	Distance W	3 x Sn
	Distance S	1 x B
	Distance G	6 x Sn
	Width active area B	25 mm