

Inductive Sensor BI5-G18-AP6X 10M

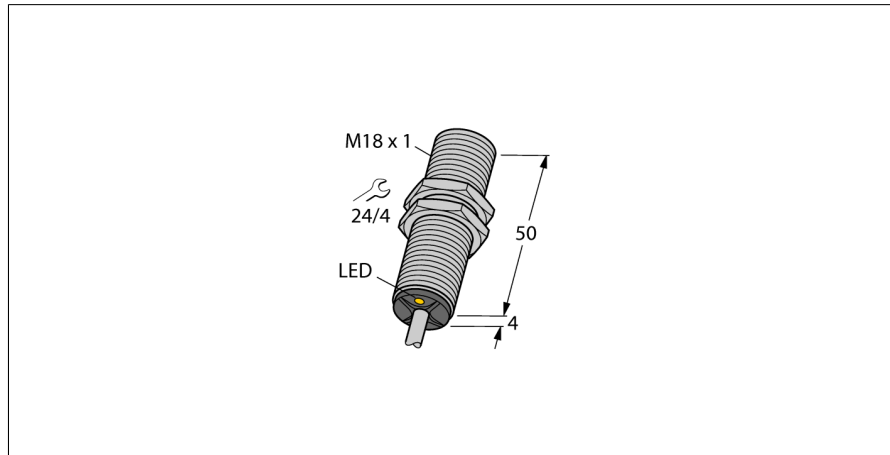

- Threaded barrel, M18 x 1
- Chrome-plated brass
- DC 3-wire, 10...30 VDC
- NO contact, PNP output
- Cable connection

Wiring Diagram

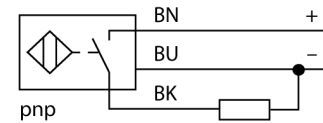

Functional principle

Inductive sensors detect metal objects contactless and wear-free. For this, they use a high-frequency electromagnetic AC field that interacts with the target. Inductive sensors generate this field via an RLC circuit with a ferrite coil.

Type	BI5-G18-AP6X 10M
ID	4641401
General data	
Rated switching distance S_n	5 mm
Mounting conditions	Flush
Secured operating distance	$\leq (0.81 \times S_n)$ mm
Correction factors	St37 = 1; Al = 0.3; stainless steel = 0.7; Ms = 0.4
Repeat accuracy	$\leq 2\%$ of full scale
Temperature drift	$\leq \pm 10\%$
Hysteresis	3...15 %
Electrical data	
Operating voltage	10...30 VDC
Residual ripple	$\leq 10\% U_{is}$
DC rated operational current	≤ 200 mA
Residual current	≤ 0.1 mA
Isolation test voltage	≤ 0.5 kV
Short-circuit protection	yes/ Cyclic
Voltage drop at I_n	≤ 1.8 V
Wire breakage/Reverse polarity protection	yes/ Complete
Output function	3-wire, NO contact, PNP
Switching frequency	0.5 kHz
Mechanical data	
Design	Threaded barrel, M18 x 1
Dimensions	54 mm
Housing material	Metal, CuZn, Chrome-plated
Active area material	Plastic, PA12-GF30
End cap	Plastic, EPTR
Max. tightening torque of housing nut	25 Nm
Electrical connection	Cable
Cable quality	\varnothing 5.2mm, LifYY, PVC, 10 m
Core cross-section	3 x 0.34 mm ²

Environmental conditions	
Ambient temperature	-25...+70 °C
Vibration resistance	55 Hz (1 mm)
Shock resistance	30 g (11 ms)
Protection class	IP67
MTTF	2283 years acc. to SN 29500 (Ed. 99) 40 °C
Switching state	
	LED, Yellow

Accessories

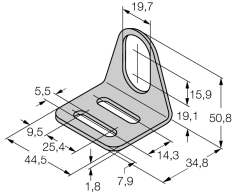
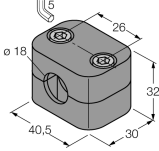
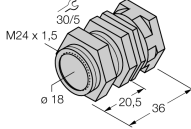
Type code	Ident-No.		Dimension drawing
MW-18	6945004	Mounting bracket for threaded barrel sensors; material: Stainless steel A2 1.4301 (AISI 304)	 <p>Technical drawing of a mounting bracket for threaded barrel sensors. The drawing shows a side view of a U-shaped bracket with a central slot. Dimensions are provided in millimeters: 19.7 (width of the top flange), 15.9 (height of the top flange), 50.8 (total height), 19.1 (width of the central slot), 14.3 (width of the bottom flange), 34.8 (width of the bottom flange), 7.9 (height of the bottom flange), 1.8 (thickness of the bottom flange), 44.5 (total width), 25.4 (width of the central slot), 9.5 (width of the top flange), and 5.5 (width of the top flange).</p>
BSS-18	6901320	Mounting clamp for smooth and threaded barrel sensors; material: Polypropylene	 <p>Technical drawing of a mounting clamp for smooth and threaded barrel sensors. The drawing shows a perspective view of a rectangular clamp with a central slot. Dimensions are provided in millimeters: 26 (width), 32 (height), 30 (width of the bottom flange), 40.5 (total width), and 18 (diameter of the central slot). A small dimension of 5 is also indicated.</p>
QM-18	6945102	Quick-mount bracket with dead-stop; material: Chrome-plated brass. Male thread M24 × 1.5. Note: The switching distance of the proximity switches may change when using quick-mount brackets.	 <p>Technical drawing of a quick-mount bracket with a dead-stop. The drawing shows a perspective view of a cylindrical bracket with a male thread. Dimensions are provided in millimeters: 30.5 (width of the top flange), 20.5 (width of the bottom flange), 36 (total width), 18 (diameter of the central slot), and M24 x 1.5 (thread specification).</p>