

BL67 electronic module

4 Analog Inputs for Current/Voltage

BL67-4AI-V/I

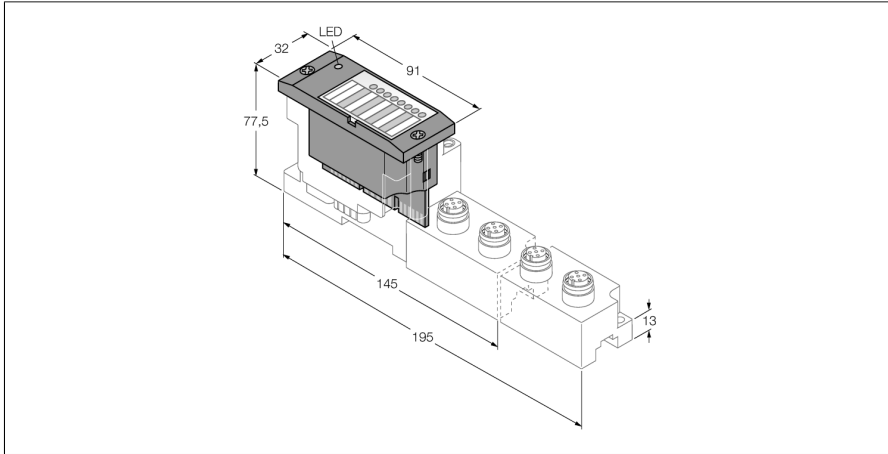

- Independent of the fieldbus and connection technology used
- Protection class IP67
- LEDs indicate status and diagnostic
- Electronics galvanically separated from the field level via optocouplers
- 4 analog inputs, single-ended
- 0/4...20 mA or
- -10/0...+10 VDC
- Selectable per channel

Functional principle





BL67 electronic modules are plugged on the purely passive base modules which in turn are connected to the field devices. The separation of connection level and electronics simplifies maintenance considerably. Flexibility is enhanced because the user can choose between base modules with different connection technologies.

The electronic modules are completely independent of the higher level fieldbus through the use of gateways.

Type	BL67-4AI-V/I
ID	6827222
Number of channels	4
Supply voltage	24 VDC
Nominal voltage V_i	24 VDC
Nominal current from field supply	≤ 12 mA
Nominal current from module bus	≤ 35 mA
Max. sensor supply I_{sens}	4 A electronically limited current supply via gateway or power feed
Power dissipation, typical	≤ 1 W
Inputs	
Input type	0/4...20 mA or -10/0...10 VDC
Input resistance	0.125 or 98.5 k Ω
Output connectivity	M12
Maximum limiting frequency analog	< 20 Hz
Basic fault limit at 23 °C	< 0.3 %
Repeatability	0.05 %
Temperature coefficient	< 300 ppm/°C of full scale
Resolution	16 Bit
Measuring principle	Sigma Delta
Measured-value display	16 bit signed integer
	12 bit full range left justified
Number of diagnostics bytes	4
Number of parameter bytes	4

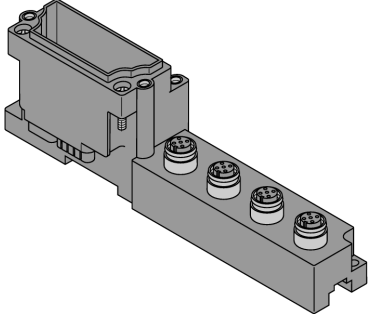
Dimensions (W x L x H)	32 x 91 x 59 mm
Approvals	CE, cULus
Ambient temperature	-40...+70 °C
Storage temperature	-40...+85 °C
Relative humidity	5...95 % (internal), level RH-2, no condensation (when stored at 45 °C)
Vibration test	Acc. to EN 61131
- up to 5 g (at 10 to 150 Hz)	for mounting on DIN rail no drilling according to EN 60715, with end bracket
- up to 20 g (at 10 up to 150 Hz)	for mounting on base plate or machinery Therefore every second module has to be mounted with two screws each.
Shock test	Acc. to IEC 60068-2-27
Drop and topple	acc. to IEC 68-2-31 and free fall to IEC 68-2-32
Electromagnetic compatibility	Acc. to EN 61131-2
Protection class	IP67
Tightening torque fixing screw	0.9...1.2 Nm

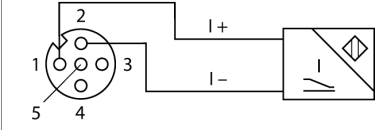
Compatible base modules

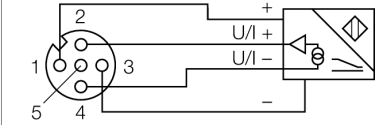
Dimension drawing	Type	Pin configuration
	<p>BL67-B-4M12 6827187 4 x M12, 5-pole, female, a-coded</p> <p>Comments Matching connection cable (for example): RKC5.501T-2-RSC5.501T/TXL Ident-No. 6628831</p> <p>Note Pin 3 (GND) and Pin 4 (AI -) are internally connected!</p>	<p>Pin Assignment</p> <p>⌋</p> <p>  </p> <p> 1 = V_{SENS} 2 = AI + 3 = GND 4 = AI - 5 = PE </p> <p>2-wire Technology</p> <p>  </p> <p>3-wire Technology</p> <p>  </p> <p>4-wire Technology</p> <p>  </p>

LED display

LED	Color	Status	Meaning
D		OFF	No error message or diagnostics active.
	RED	ON	Failure of module bus communication. Check if more than 2 adjacent electronic modules are pulled. Relevant modules are located between gateway and this module.
	RED	FLASHING (0.5 Hz)	Upcoming module diagnostics
AI channel 0...3		OFF	Not active
	GREEN	ON	Active
	GREEN	FLASHING (0.5 Hz)	Underflow in measuring range
	GREEN	FLASHING (4 Hz)	Overflow in measuring range

Data mapping

DATA	BYTE	Bit 7	Bit 6	Bit 5	Bit 4	Bit 3	Bit 2	Bit 1	Bit 0
Input	n	AI 0 LSB							
	n+1	AI 0 MSB							
	n+2	AI 1 LSB							
	n+3	AI 1 MSB							
	n+4	AI 2 LSB							
	n+4	AI 2 MSB							
	n+6	AI 3 LSB							
	n+7	AI 3 MSB							

n = Offset of input data; depending on extension of station and the corresponding fieldbus.

m = Offset of output data; depending on extension of station and the corresponding fieldbus.

With PROFIBUS, PROFINET and CANopen, the I/O data of this module is localized within the process data of the whole station via the hardware configuration tool of the fieldbus master.

With DeviceNet™, EtherNet/IP™ and Modbus TCP a detailed mapping table can be created with the TURCK configuration tool I/O-ASSISTANT.