

# TS-516-LI2UPN8X-H1141-L016

## Temperature Detection – With Current Output and PNP/NPN Transistor Switching Output

### Output 2 Reprogrammable as Switching Output

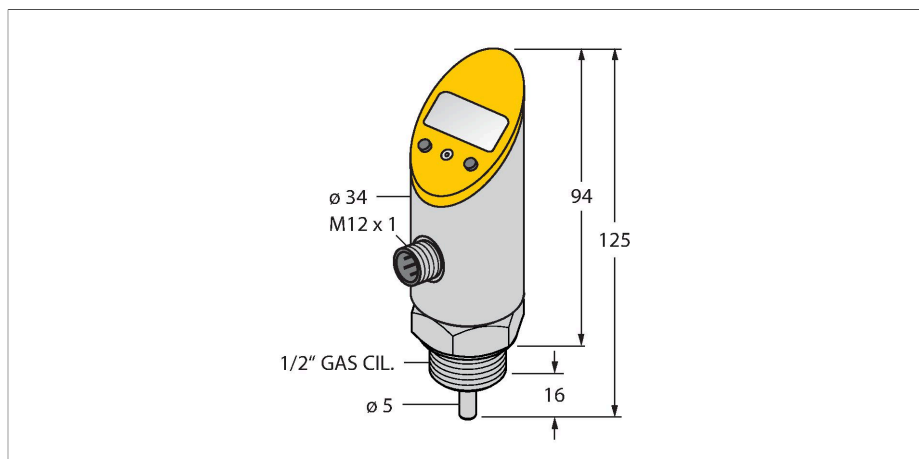

#### Technical data

Type	TS-516-LI2UPN8X-H1141-L016
ID	6840026
<b>Temperature range</b>	
Measuring range	-50...150 °C
Measuring range	-58...302 °F
Accuracy	±0.15 K + 0.002 • t  (-30...300 °C)
Measuring element	Pt-100 probe, DIN EN 60751, class A
Response time	t 0.5 = 6 s / t 0.9 = 15 s in water at 0.2 m/s
Immersion depth (L)	16 mm
Process Pressure	160 bar
<b>Power supply</b>	
Operating voltage	18...30 VDC
Current consumption	≤ 50 mA
Protective measure	SELV; PELV according to EN 50178
Short-circuit/reverse polarity protection	yes / yes
Insulation class	III
<b>Outputs</b>	
Output 1	Switching output or IO-Link mode
Output 2	Analog or switching output
<b>Switching output</b>	
Communication protocol	IO-Link

#### Features

- Housing is rotatable after plugging the process connection
- Reading of adjusted values without tools
- Recessed pushbutton and keylock for secure programming
- Permanent display of temperature unit (°C, °F, K, Ohm)
- Temperature peak memory

#### Wiring diagram

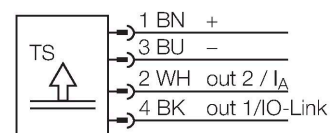

#### Functional principle

The TS series is a compact processing unit with a 4-digit, 7-segment display. Available are versions with non-rotatable (TS400) or rotatable (TS500) body and various output types.

## Technical data

Output function	NO/NC programmable, PNP/NPN
Switching point accuracy	$\pm 0.3$ K
Rated operational current	0.2 A
Switching frequency	$\leq 180$ Hz
Release position	-50...+149.8 °C
Switching point	-49.8...+150 °C
Switching point distance	$\geq 0.2$ K
Switching cycles	$\geq 100$ mil.
<b>Analog output</b>	
Current output	4...20 mA
Load	$\leq 0.5$ k $\Omega$
Accuracy (Lin. + Hys. + Rep.)	$\pm 0.3$ K
Remark	0.1% of full scale applies to temperatures > 200 °C
Repeatability	0.1 K
<b>IO-Link</b>	
IO-Link specification	V 1.0
Transmission physics	corresponds to 3-wire physics (PHY2)
Frame type	2.2
Transmission rate	COM 2 / 38.4 kbps
Process data width	16 bit
Measured value information	14 bit
Switchpoint information	1 bit
Programming	FDT / DTM
Genauigkeit	$\pm 0.2$ K
Included in the SIDI GSDML	Yes
Programming options	switch/release point, hysteresis/window mode, NO/NC; unit
<b>Mechanical data</b>	
Housing material	Stainless-steel/Plastic, 1.4305 (AISI 303)
Process connection	G 1/2" male thread
Wrench size pressure connection / coupling nut	30
Electrical connection	Connector, M12 $\times$ 1
Protection class	IP67 IP69K
<b>Environmental conditions</b>	
Ambient temperature	-40...+80 °C
Storage temperature	-40...+80 °C

## Technical data

Shock resistance	50 g (11 ms) acc. to IEC 68-2-27
Vibration resistance	20 g (9...2000 Hz), according to IEC 68-2-6
EMV	EN 61000-4-2 ESD:4 kV CD / 8 kV AD EN 61000-4-3 HF radiated:15 V/m EN 61000-4-4 Burst:2 kV EN 61000-4-5 Surge: 1 kV, 42 Ohm EN 61000-4-6 HF conducted:10 V
<b>Tests/approvals</b>	
Reference conditions acc. to IEC 61298-1	
Temperature	15...+25 °C
Atmospheric pressure	860...1060 hPa abs.
Humidity	45...75 % rel.
Auxiliary power	24 VDC
<b>Displays/Operating elements</b>	
Display	4-digit 7-segment display, rotatable by 180°
Switching state	2 × LEDs, Yellow
Unit display	4 x green LED (°C, °F, K, Ohm)
<b>Temperature behaviour</b>	
Temperature coefficient range $TK_s$	± 0.15 % of full scale/10 K
Temperature coefficient zero point $TK_0$	± 0.15 % of full scale/10 K
MTTF	255 years acc. to SN 29500 (Ed. 99) 20 °C

## Technical data

Type	TS-516-LI2UPN8X-H1141-L016
ID	6840026
<b>Temperature range</b>	
Measuring range	-50...150 °C
Measuring range	-58...302 °F
Accuracy	±0.15 K + 0.002 • t  (-30...300 °C)
Measuring element	Pt-100 probe, DIN EN 60751, class A
Response time	t 0.5 = 6 s / t 0.9 = 15 s in water at 0.2 m/s
Immersion depth (L)	16 mm
Outer diameter	6 mm
<b>Power supply</b>	
Operating voltage	18...30 VDC
Current consumption	≤ 50 mA
Voltage drop at $I_o$	≤ 2 V

## Technical data

Protective measure	SELV; PELV according to EN 50178
Short-circuit/reverse polarity protection	yes / yes
Protection type and class	IP67 IP69K / III
<b>Outputs</b>	
Output 1	Switching output or IO-Link mode
Output 2	Analog or switching output
<b>Switching output</b>	
Communication protocol	IO-Link
Output function	NO/NC programmable, PNP/NPN
Switching point accuracy	± 0.3 K
Rated operational current	0.2 A
Switching frequency	≤ 180 Hz
Switching point distance	≥ 0.2 K
Switching cycles	≥ 100 mil.
Release position	-50...+149.8 °C
Switching point	-49.8...+150 °C
<b>Analog output</b>	
Current output	4...20 mA
Load	≤ 0.5 kΩ
Accuracy (Lin. + Hys. + Rep.)	± 0.3 K
Remark	0.1% of full scale applies to temperatures > 200 °C
Repeatability	0.1 K
<b>IO-Link</b>	
IO-Link specification	V 1.0
Programming	FDT / DTM
Transmission physics	corresponds to 3-wire physics (PHY2)
Transmission rate	COM 2 / 38.4 kbps
Process data width	16 bit
Measured value information	14 bit
Switchpoint information	1 bit
Frame type	2.2
Genauigkeit	± 0.2 K
Included in the SIDI GSDML	Yes
<b>Temperature behaviour</b>	
Temperature coefficient zero point TK <sub>0</sub>	± 0.15 % of full scale/10 K
Temperature coefficient range TK <sub>s</sub>	± 0.15 % of full scale/10 K

## Technical data

Environmental conditions	
Ambient temperature	-40...+80 °C
Storage temperature	-40...+80 °C
Vibration resistance	20 g (9...2000 Hz), according to IEC 68-2-6
Shock resistance	50 g (11 ms) acc. to IEC 68-2-27
EMV	EN 61000-4-2 ESD:4 kV CD / 8 kV AD EN 61000-4-3 HF radiated:15 V/m EN 61000-4-4 Burst:2 kV EN 61000-4-5 Surge: 1 kV, 42 Ohm EN 61000-4-6 HF conducted:10 V
Mechanical data	
Housing material	Stainless-steel/Plastic, 1.4305 (AISI 303)
Process connection	G 1/2" male thread
Process Pressure	160 bar
Wrench size pressure connection / coupling nut	30
Electrical connection	Connector, M12 × 1
Reference conditions acc. to IEC 61298-1	
Temperature	15...+25 °C
Atmospheric pressure	860...1060 hPa abs.
Humidity	45...75 % rel.
Auxiliary power	24 VDC
Displays/Operating elements	
Display	4-digit 7-segment display, rotatable by 180°
Switching state	2 × LEDs, Yellow
Unit display	4 x green LED (°C, °F, K, Ohm)
Programming options	switch/release point, hysteresis/window mode, NO/NC; unit
Tests/approvals	
MTTF	255 years acc. to SN 29500 (Ed. 99) 20 °C