

FCS-G1/2A4-AP8X-H1141/L065

Flow Monitoring – Immersion Sensor with Integrated Processor

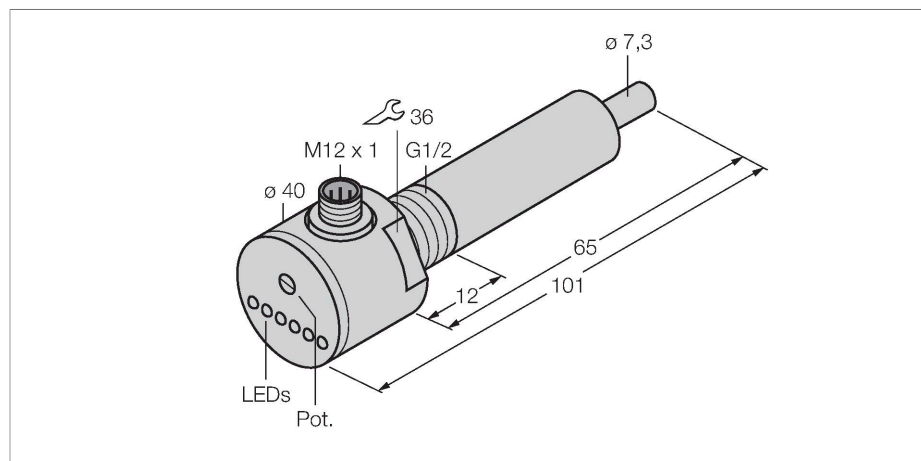

Features

- Sensor for liquid media
- Calorimetric principle
- Adjustment via potentiometer
- Status indicated via LED chain
- Sensor length 65 mm
- DC 3-wire, 19.2...28.8 VDC
- NO contact, PNP output
- Connector device, M12 × 1

Wiring diagram

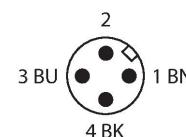
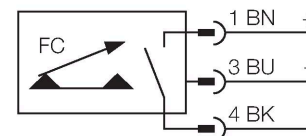

Functional principle

The function of immersion flow sensors is based on the thermodynamic principle. The sensor is heated up by a few degrees Celsius compared to the flow medium. If the medium flows past the sensor, the heat generated in the sensor is dissipated. The resulting temperature is measured and compared with the temperature of the medium. The flow condition of each medium can be derived from the temperature difference obtained. Thus, TURCK flow sensors reliably and wear-free monitor the flow of liquid or gaseous media.

Technical data

ID	6870017
Type	FCS-G1/2A4-AP8X-H1141/L065
Mounting	Immersion sensor
Water Operating Range	1...150 cm/s
Oil Operating Range	3...300 cm/s
Stand-by time	typ. 8 s (2...15 s)
Switch-on time	typ. 2 s (1...15 s)
Switch-off time	typ. 2 s (1...15 s)
Temperature jump, response time	max. 12 s
Temperature gradient	≤ 250 K/min
Medium temperature	-20...+80 °C
Ambient temperature	-20...+80 °C
Electrical data	
Operating voltage	19.2...28.8 VDC
Output function	PNP, NO contact
Rated operational current	0.4 A
Voltage drop at I _o	≤ 1.5 V
Short-circuit protection	yes
Reverse polarity protection	yes
Protection class	IP67
Mechanical data	
Design	Immersion
Housing material	Stainless steel, 1.4571 (AISI 316Ti)
Sensor material	Stainless steel, 1.4571 (AISI 316Ti)

Technical data

Max. tightening torque of housing nut	30 Nm
Electrical connection	Connector, M12 × 1
Process Pressure	100 bar
Process connection	G 1/2"
Switching state	LED chain, Green/yellow/red
Flow state display	LED chain
Indication: Drop below setpoint	LED Red
Indication: Setpoint reached	LED Yellow
Indication: Setpoint exceeded	4 × LEDs Green
Tests/approvals	
Approvals	cULus
UL registration number	E210608