

FCS-M18-LIX/D067

Flow Monitoring – Immersion Sensor with Integrated Processor

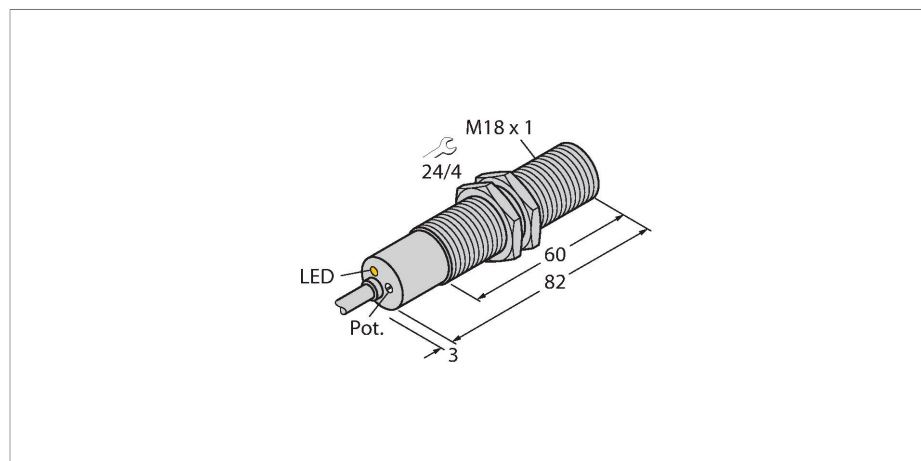

Features

- Flow sensor for gaseous media
- Calorimetric principle
- Adjustment via potentiometer
- Power-on LED
- Nickel-plated brass sensor
- DC 3-wire, 19.2...28.8 VDC
- 4...20 mA analog output

Wiring diagram

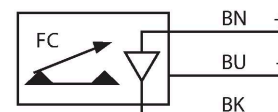

Technical data

ID	6870712
Type	FCS-M18-LIX/D067
Special version	D067 Corresponds to: FCS-M18-LIX mit erweitertem Arbeitsbereich 0,5...50 m/s
Mounting	Immersion sensor
Air Operating Range	0.5...50 m/s
Stand-by time	20...40 s
Setting time	typ. 2 s
Temperature gradient	≤ 200 K/min
Medium temperature	-20...+70 °C
Ambient temperature	-20...+70 °C
Electrical data	
Operating voltage U_b	19.2...28.8 VDC
Current consumption	≤ 70 mA
Output function	Analog output
Short-circuit protection	yes
Reverse polarity protection	yes
Current output	4...20 mA
Load	200...500 Ω
Protection class	IP67
Mechanical data	
Design	Immersion
Housing material	Metal, CuZn
Sensor material	Brass, brass, nickel-plated

Functional principle

The function of immersion flow sensors is based on the thermodynamic principle. The sensor is heated up by a few degrees Celsius compared to the flow medium. If the medium flows past the sensor, the heat generated in the sensor is dissipated. The resulting temperature is measured and compared with the temperature of the medium. The flow condition of each medium can be derived from the temperature difference obtained. Thus, TURCK flow sensors reliably and wear-free monitor the flow of liquid or gaseous media.

Technical data

Electrical connection	Cable
Cable length (L)	2 m
Core cross-section	3 x 0.5 mm ²
Process connection	M18 × 1
Power on display	LED, Green
Tests/approvals	