

FCS-N1/2A4P-AP8X-H1141

Flow Monitoring – Immersion Sensor with Integrated Processor

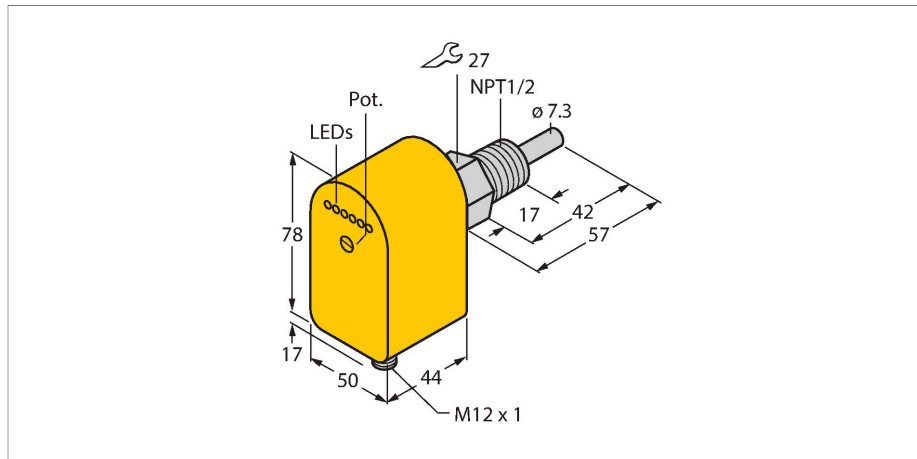

Features

- Sensor for liquid media
- Calorimetric principle
- Adjustment via potentiometer
- Status indicated via LED chain
- DC 3-wire, 19.2...28.8 VDC
- NO contact, PNP output
- Connector device, M12 × 1

Wiring diagram

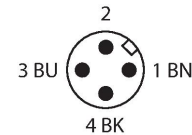
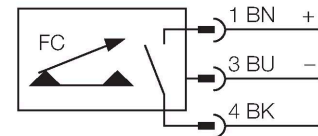

Technical data

| | |
|---------------------------------|------------------------|
| ID | 6871032 |
| Type | FCS-N1/2A4P-AP8X-H1141 |
| Mounting | Immersion sensor |
| Water Operating Range | 1...150 cm/s |
| Oil Operating Range | 3...300 cm/s |
| Stand-by time | typ. 8 s (2...15 s) |
| Switch-on time | typ. 2 s (1...15 s) |
| Switch-off time | typ. 2 s (1...15 s) |
| Temperature jump, response time | max. 12 s |
| Temperature gradient | ≤ 250 K/min |
| Medium temperature | -20...+80 °C |
| Ambient temperature | -20...+70 °C |
| Electrical data | |
| Operating voltage | 19.2...28.8 VDC |
| Current consumption | ≤ 60 mA |
| Output function | PNP, NO contact |
| Rated operational current | 0.4 A |
| Voltage drop at I _o | ≤ 1.5 V |
| Short-circuit protection | yes |
| Reverse polarity protection | yes |
| Protection class | IP67 |
| Mechanical data | |
| Design | Immersion |
| Housing material | Plastic, PBT |

Functional principle

The function of immersion flow sensors is based on the thermodynamic principle. The sensor is heated up by a few degrees Celsius compared to the flow medium. If the medium flows past the sensor, the heat generated in the sensor is dissipated. The resulting temperature is measured and compared with the temperature of the medium. The flow condition of each medium can be derived from the temperature difference obtained. Thus, TURCK flow sensors reliably and wear-free monitor the flow of liquid or gaseous media.

Technical data

| | |
|---------------------------------------|--------------------------------------|
| Sensor material | Stainless steel, 1.4571 (AISI 316Ti) |
| Max. tightening torque of housing nut | 30 Nm |
| Electrical connection | Connector, M12 × 1 |
| Process Pressure | 100 bar |
| Process connection | 1/2" NPT |
| Switching state | LED chain, Green/Yellow/Red |
| Flow state display | LED chain |
| Indication: Drop below setpoint | LED Red |
| Indication: Setpoint reached | LED Yellow |
| Indication: Setpoint exceeded | 4 × LEDs Green |
| Tests/approvals | |
| Approvals | cULus |
| UL registration number | E210608 |