

TW-R20-K2 HF Tag

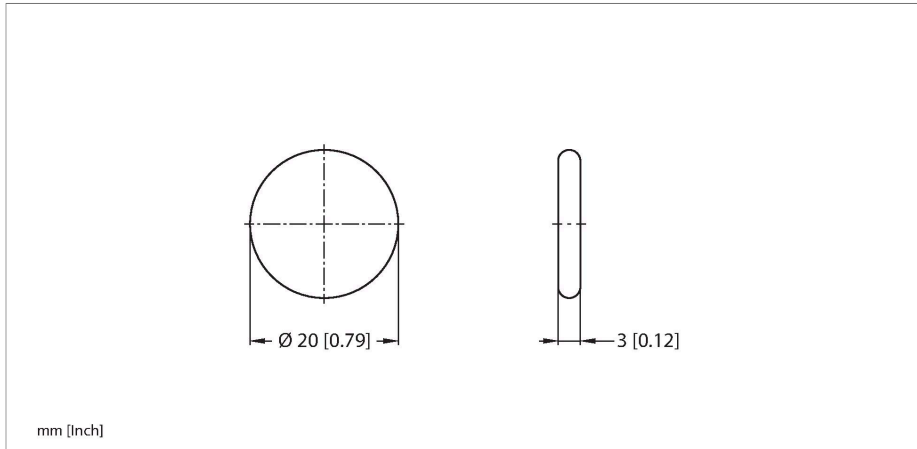

Technical data

Type	TW-R20-K2
ID	6900505
Remark to product	Not suitable for direct mounting on metal
Data transfer	Inductive coupling
Technology	HF RFID
Operating frequency	13.56 MHz
Memory type	FRAM
Chip	Fujitsu MB89R118
Memory size	2048 Byte
Memory	Read/Write
Freely usable memory	2000 Byte
Number of read operations	unlimited
Number of write operations	10 ¹⁰
Typical read time	0.5 ms/Byte
Typical write time	0.5 ms/Byte
Radio communication and protocol standards	ISO 15693 NFC Typ 5
Minimum distance to metal	10 mm
Temperature during read/write access	-40...+85 °C
Temperature outside detection range	-40...+90 °C
	140 °C, 1 × 100 h
Design	Hard tag, R20
Diameter	20 mm +0.7/-0.5 mm
Housing height	3 mm +0.7/-0.5 mm
Housing material	Plastic, PA6

Features

- The tags must undergo adequate stress tests within the proposed temperature processes before deployment.
- The following stress test was performed on this tag:
Cyclic temperature stress: 5 min at -40 °C – 5 min at 90 °C
Number of tested cycles: 100, transition period: 30 seconds
Continuous load: 140 °C for 100 hours
- This successfully performed test does not imply suitability for a specific application, but merely serves as proof of the basic usability.
- FRAM memory 2 kB
- Not for direct mounting on metal

Functional principle

The HF read/write devices operating at a frequency of 13.56 MHz form a transmission zone the size of which (0...500 mm) varies, depending on the combination of read/write head and tag used.

The read/write distances mentioned here only represent standard values measured under laboratory conditions, free from any influences caused by surrounding materials.

The read/write distances of tags suitable for mounting in/on metal were determined in/on metal.

Attainable distances may vary by up to 30 % due to component tolerances, mounting conditions, ambient conditions and material qualities (especially when mounted in metal). Testing of the application under real operating conditions is therefore essential, especially with on-the-fly reading and writing!

Technical data

Active area material	Plastic, PA6, black
Protection class	IP69K
Packaging unit	1