

TW-R12-M-B146

HF Tag

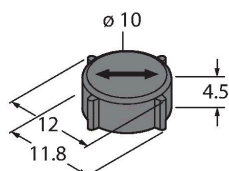

Technical data

Type	TW-R12-M-B146
ID	7030500
Remark to product	Tag for direct mounting on/in metal. A recommendation for adhesives, the requirements of the FDA and the EU for incidental food contact can be requested from TURCK. This recommendation does not relieve the user of an examination with regard to the suitability for his application.
Data transfer	Inductive coupling
Technology	HF RFID
Operating frequency	13.56 MHz
Memory type	EEPROM
Chip	EM4233SLIC
Memory	146 Byte
Memory	Read/Write
Freely usable memory	128 Byte
Number of read operations	unlimited
Number of write operations	10 ⁵
Typical read time	2 ms/Byte
Typical write time	3 ms/Byte
Radio communication and protocol standards	ISO 15693 NFC Typ 5
Minimum distance to metal	0 mm
Temperature during read/write access	-40...+85 °C
Temperature outside detection range	-40...+130 °C

Features

- Tag for direct mounting on metal
- The mounting position (arrow) as well as the alignment of the tag towards the read/write head must be observed under all circumstances in order to achieve a maximum read/write distance
- When installed recessed in metal by 1 mm, the write/read distance reduces to 30%
- Extended storage temperature range: The tags must undergo adequate stress tests within the proposed temperature processes before deployment.
- The following stress test was performed on this tag:
Cyclic temperature stress: 5 min. at 20 °C – 5 min. at 160 °C.
Number of tested cycles: 100T
This successfully performed test does not imply suitability for a specific high-temperature application, but merely serves as proof of the basic usability.
- EEPROM, memory 146 byte
- For direct mounting on metal

Functional principle

The HF read/write devices operating at a frequency of 13.56 MHz form a transmission zone the size of which (0...500 mm) varies, depending on the combination of read/write head and tag used.

The read/write distances mentioned here only represent standard values measured under laboratory conditions, free from any influences caused by surrounding materials.

The read/write distances of tags suitable for mounting in/on metal were determined in/on metal.

Attainable distances may vary by up to 30 % due to component tolerances, mounting conditions, ambient conditions and material qualities (especially when mounted in metal).

Technical data

	130 °C, 1000 h
	160 °C
Design	Hard tag, R12
Diameter	12 mm ± 0.25 mm
Housing height	4.5 mm +/-0.3mm
Housing material	Plastic, open housing, potted, PPS Epoxy
Active area material	Plastic, PPS, black
Protection class	IP68
Packaging unit	1

Testing of the application under real operating conditions is therefore essential, especially with on-the-fly reading and writing!

Mounting instructions/Description

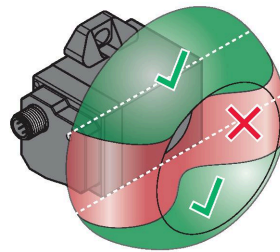
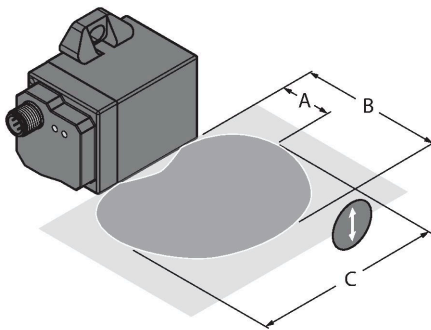

The left figure shows how the read/write head must be aligned towards the data carrier.

As an example here the read/write head TNSLR-Q42TWD-H1147 is shown (instructions valid for all suitable read/write heads).

The orientation of the data carrier (arrow) is to be observed.

A: Recommended distance

B: Maximum distance

C: Length of the transmission zone at recommended distance

The corresponding values are listed in the table.

To achieve the largest possible distance, the data carrier must be positioned off-center to the read/write head, or rather move along the housing edges during the readwrite process.

The figure on the right shows the typical spread of a data transmission zone

Glueing the data carrier:

Step 1: First, mill a sufficiently large bore hole (see drawing)

Step 2: Fill the hole with sufficient adhesive or potting material

Step 3: Press the data carrier into the hole.

Observe

the orientation of the data carrier (see arrow)

A subsequent alignment of the data carrier in the hole is not possible.

Step 4: In order to avoid holes and undercuts, first, let harden the adhesive after inserting the data carrier. This also avoids any unintentional rotation of the data carrier. Then, fill up with adhesive and flush with the surface.