

GSDFA 40-xM/14.5/NPT Power Receptacle – Front Mount

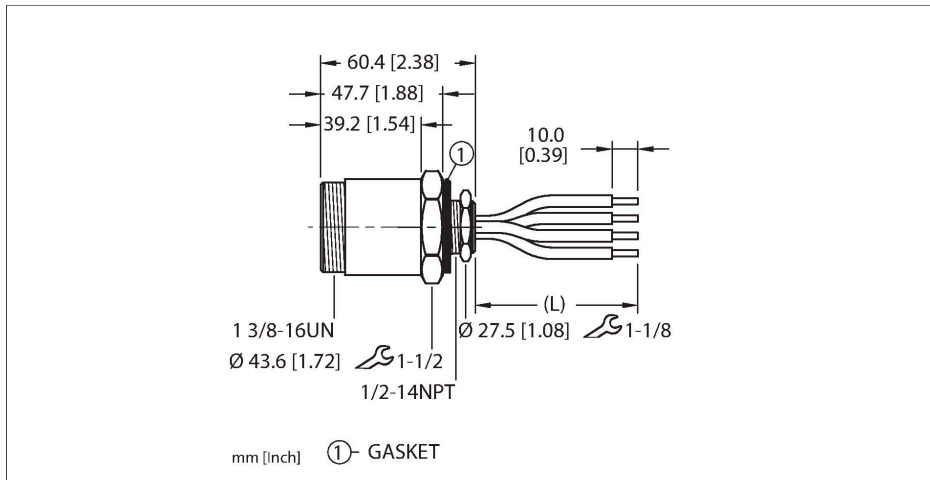

Features



- Male 1 3/8" powerfast Receptacle, 4 pin
- Mounting thread: 1/2"-14 NPT

Contact assignment

Connector A

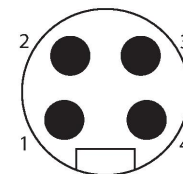

Circuit Diagram



Mounting hole - Through

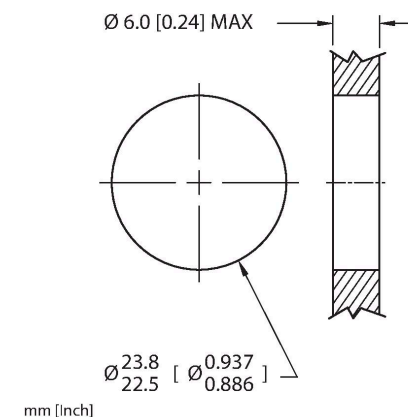

Technical data

Type	GSDFA 40-xM/14.5/NPT
ID	777023448
Connector A	Male, 1 3/8"-16 UN
Number of contacts	4
Contacts	Brass, CuZn, Gold-plated
Contact carriers	Plastic, PVC, Black
Housing material/finish	Aluminum, Aluminum, Anodized
Tightening torque (range)	0.8 ... 2 Nm (note max. torque of mating connector!)
Mounting orientation	Front mount
Panel seal	Gasket
Mounting thread	1/2"-14 NPT
Locknut	Brass, CuZn, Nickel-plated
Mechanical life	> 100 Mating cycles
Pollution degree	3
Protection class (When coupled)	IP67, IP68, IP69K
	NEMA: 1, 3, 4, 6P
Total number of conductors	4
Conductor material	TC (tinned copper)
Conductor insulation material	PVC
Conductor size	10 AWG [Similar to 6.00 mm ²]
Conductor colors	RD, BK, WH, GN/YL
Electrical properties at +20 °C	
Rated voltage	600 V

Technical data

Current	35 A
Mechanical and chemical properties	
Ambient temperature range (static)	-40 °C...+105 °C
Approvals	CE RoHS UL 2237
Note	
- CAUTION: RISK OF ELECTRICAL SHOCK. DO NOT DISCONNECT UNDER LOAD.	
- We reserve the right to make technical alterations without prior notice.	

Front panel mounting

