

8MB12Z-5-CS19H

Passive Actuator/Sensor Box, M12 × 1 – 8-port, with M23 homerun connector

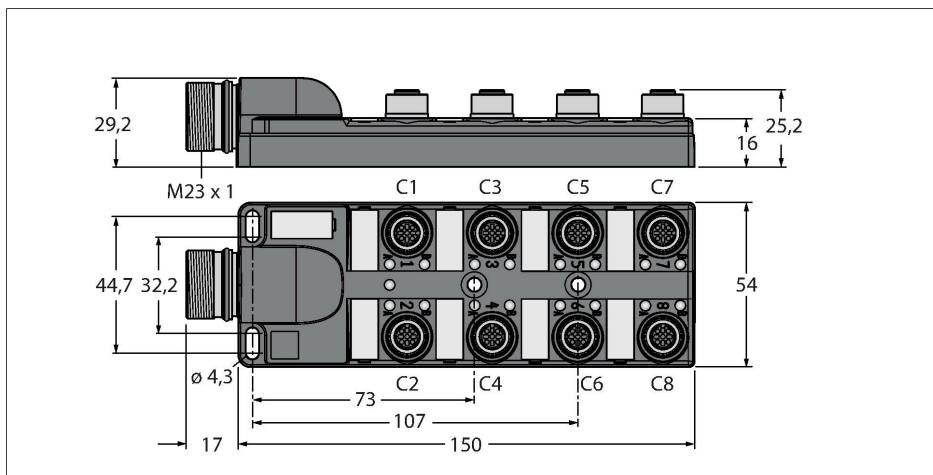

Technical data

Type	8MB12Z-5-CS19H
ID	E8033448
Distributed I/O	Junction box, 8 -port, with integral M23 x 1 connector
Housing	Plastic, PA6-GF30, Black
I/O Port	Female, M12 × 1
Number of contacts	4+PE
Contacts	Brass, CuZn, Gold-plated
Contact carriers	Plastic, PA 4.6 GF30, Black
Connector seal	O-ring, Plastic, FKM/FPM
Housing material/finish	Brass, CuZn, Nickel-plated
Tightening torque (range)	0.8 ... 1 Nm
Mechanical life	> 100 Mating cycles
Pollution degree	3
Protection class (When coupled)	IP67
Homerun connector	Male, M23 × 1, Side exit
Number of contacts	19
Contacts	Brass, CuZn, Gold-plated
Contact carriers	Plastic, PBT, Black
Seal	Plastic, NBR
Tightening torque	2 Nm
Mechanical life	> 100 Mating cycles
Pollution degree	3

Features



- Housing material: PA 6 GF30
- Housing color: Black
- Fully encapsulated
- Protection class: IEC: IP67; NEMA: 1, 3, 4, 6P
- CE compliant
- RoHS compliant
- I/O port: 5-pin

Contact assignment

I/O Connector

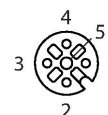

Homerun connector

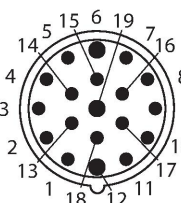

Technical data

Protection class (When coupled)	IP67
Electrical properties at +20 °C	
Rated voltage	60 VDC
Current	2 A per signal contact, total current 9 A
Mechanical and chemical properties	
Ambient temperature range (static)	-40...+85 °C
Approvals	UL Listed RoHS
Note	
- We reserve the right to make technical alterations without prior notice.	

Circuit Diagram

