

RSM RKM 50-2M

power cable – PVC Cable Jacket

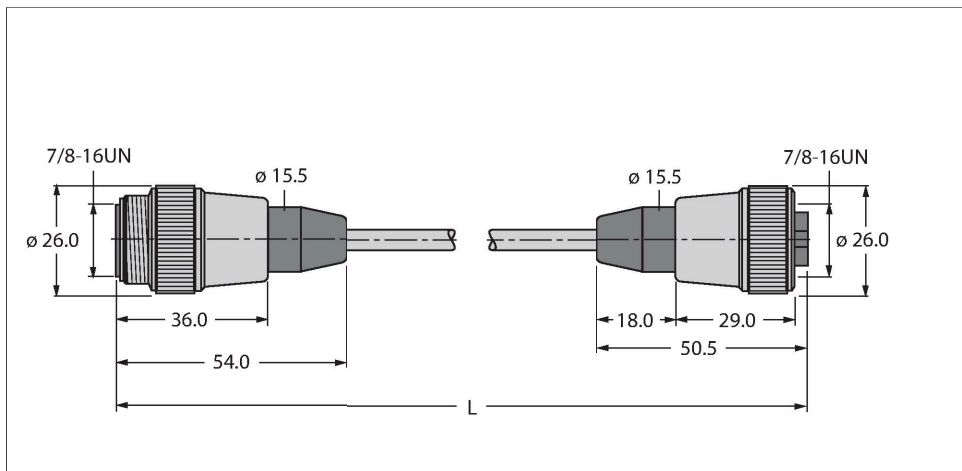

Features



- Power cable: 5 x 0.83 mm², 5 x 18 AWG
- Jacket material: PVC
- Jacket color: yellow
- Jacket diameter: 7.6 mm
- UV-resistant
- Flame-retardant acc. to CSA FT4
- UL, CSA approval
- RoHS-compliant
- Protection class: NEMA 1, 3, 4, 6P and IEC IP67
- 7/8" female, straight
- 7/8" male, straight
- Cable length: 2.0 m

Technical data

Type	RSM RKM 50-2M
Ident. no.	U2282-0
Connector A	Male, 7/8", Straight
Number of contacts	4+PE
Contacts	Metal, CuZn, Gold-plated
Contact carriers	Plastic, TPU, Yellow
Connector body	Plastic, TPU, Yellow
Coupling nut	Brass, CuZn, Nickel-plated
Mechanical life	> 100 Mating cycles
Pollution degree	3
Protection class	When coupled - IP67, Only in screwed condition
Connector B	Female, 7/8", Straight
Number of contacts	4+PE
Contacts	Metal, CuZn, Gold-plated
Contact carriers	Plastic, TPU, Yellow
Connector body	Plastic, TPU, Yellow
Coupling nut	Brass, CuZn, Nickel-plated
Mechanical lifespan	> 100 Mating cycles
Pollution degree	3
Protection class	When coupled - IP67, Only when screwed tight
Cable data	
Cable diameter	Ø 7.6 mm ± 0.30



Technical data

Cable length (L)	2 m
Cable jacket	PVC, Yellow
Conductor insulation material	PVC
Conductor size	5 x 0.83 mm ²
Number of strands x O.D.	19 x 0.25 mm
Conductor colors	BN, WH, BU, BK, GNYE
Electrical properties at +20 °C	
Rated voltage	600 V
Current	9 A
Mechanical and chemical properties	
Bending radius (static)	≥ 5 x Ø
Bending radius (dynamic)	≥ 10 x Ø
Ambient temperature	
Temperature range (static)	-40 °C...+105 °C
Other Features	
UV resistance	yes
Flame-retardant	yes