

Industrial Ethernet Managed Switch SE20-84MT-RJ822

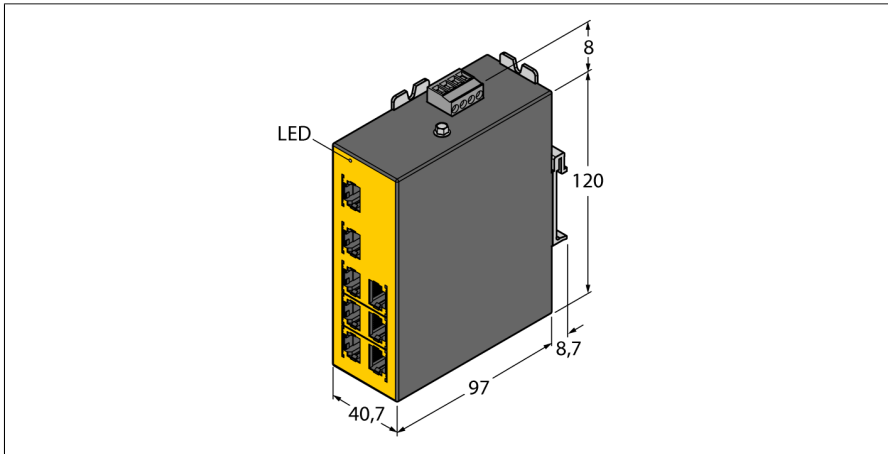

- 10/100 Mbps
- Auto-sensing, 10/100M, half/full duplex, auto-negotiating
- Auto cross-over, auto-polarity
- Automatic address learning, aging and migration
- Store and forward wire-speed switching
- IEEE 802.3, 802.3u, 802.3x, 802.3D/w, 802.3p, 802.3Q
- Real-Time-Ring™ or Rapid Spanning Tree (RSTP)
- SNMPv1 and v2 network management
- SNMPv3 authentication & encryption for security
- SNMP notifications
- IGMP for multicast filtering (snooping and querying)
- Broadcast and multicast storm protection
- RMON and port mirroring
- Security with HTTPS, SSL, SSH, SNMPv3
- Easy configuration via web
- 8 ports
- Ethernet connection: shielded RJ45 sockets
- Power supply: removable screw terminal
- Protection class: IP20

Type	SE20-84MT-RJ822
ID	U3-10865
Supply voltage	24 VDC
Admissible range	10...30 VDC
Power consumption	≤ 4.3 W
Transient Protection	15,000 Watts Peak
Spike Protection	5,000 Watts (10 times for 10 μs)
Voltage supply connection	Pluggable screw terminal strip
Transmission rate Ethernet	10/100 Mbps
Ethernet Compliance	IEEE 802.3 (10 Mbps Ethernet) IEEE 802.3u (100 Mbps Ethernet) IEEE 802.3.3 x (Full-Duplex with Flow Control) IEEE 802.1D/w (RSTP for redundant rings) IEEE 802.1p (Priority Queuing - Qos, CoS, ToS/DS) IEEE 802.1Q (VLAN for traffic segregation)
Number of Ethernet ports	8 ports
Connection technology Ethernet	8 × RJ45
Web server	Default 192.168.0.1
MAC Addresses	2048
Memory bandwidth	3.2 Gbps
Latency (typical)	@100 Mbps: 5 μs + frame time; @10 Mbps: 16 μs + frame time
Electrical isolation	1500 VRMS 1 minute
Electromagnetic compatibility (EMC)	FCC part 15, ICES-003, EN6100-6-4, IEC61000-6-2, CE
Dimensions	38.1 x 82.8 x 101.6 mm
Weight	455 g
Ambient temperature	-40...+75 °C
Storage temperature	-40...+85 °C
Relative humidity	5 to 95% (non-condensing)
Vibration test	Acc. to IEC 60068-2-6
Protection class	IP20
Mounting	Din-rail or direct panel mounting
Housing material	Aluminum

RJ45 Fieldbus

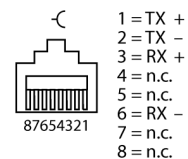

Power Supply

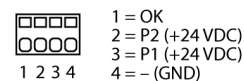

Functional principle

Ethernet switches can be used to simplify Ethernet networks and reduce traffic. They perform an important role in traffic management by forwarding messages only to the port that needs them.

Approvals and certificates	UL508/CSA C22.2/14; EN61010-1; UL1604/CSA C22.2/213 (Class I, Div. 2); EN60079-15 (Zone 2, Category 3); CE (ATEX)
Life cycle MTBF	>2M Std. GB bei 40°C gemäß MIL-HNDBK-217F2