

Industrial Ethernet Unmanaged Switch SE20-84XT-RJ422-FO

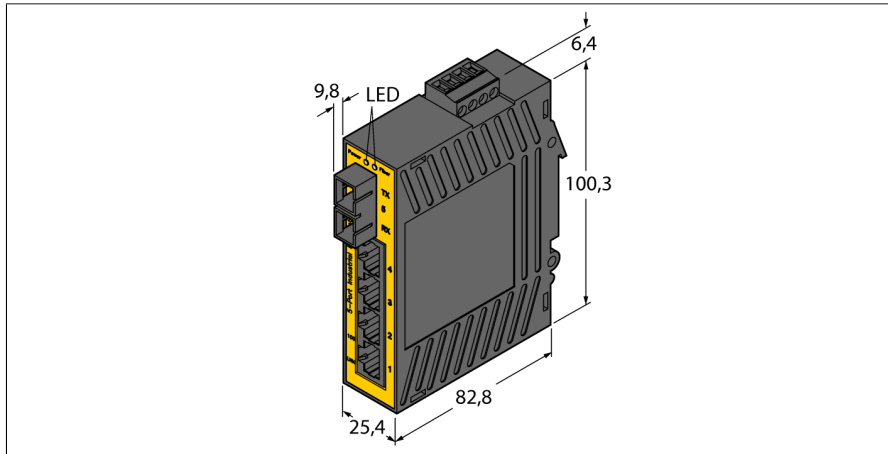

- 10/100 Mbps
- Auto-sensing, 10/100M, half/full duplex, auto-negotiating
- Auto cross-over, auto-polarity
- Automatic address learning, aging and migration
- Store and forward wire-speed switching
- IEEE 802.3, 802.3u, 802.3x
- 4 ports + 1 multi-mode fiber
- Ethernet connection: shielded RJ45 sockets
- Power supply: removable screw terminal
- Protection class: IP20

Type	SE20-84XT-RJ422-FO
ID	U3-10873
Supply voltage	24 VDC
Admissible range	10...30 VDC
Power consumption	≤ 3 W
Transient Protection	15,000 Watts Peak
Spike Protection	5,000 Watts (10 times for 10 µs)
Voltage supply connection	Pluggable screw terminal strip

Transmission rate Ethernet	10/100 Mbps
Ethernet Compliance	IEEE 802.3 (10 Mbps Ethernet) IEEE 802.3u (100 Mbps Ethernet) IEEE 802.3.3 x (Full-Duplex with Flow Control)
Number of Ethernet ports	4 ports (unmanaged) + 1 multi-mode fiber
Connection technology Ethernet	4 × RJ45, 1 × Duplex SC
MAC Addresses	1024
Memory bandwidth	3.2 Gbps
Latency (typical)	@100 Mbps: 5 µs + frame time; @10 Mbps: 16 µs + frame time
Electrical isolation	1500 VRMS 1 minute
Electromagnetic compatibility (EMC)	FCC part 15, ICES-003, EN55022, EN61000-6, CE
Fiber wavelength	1300 nm center (typical)
Fiber maximum distance (full duplex)	4km for multimode 50 or 62.5/125 µm

Dimensions	25.4 x 82.8 x 101.6 mm
Weight	223 g
Ambient temperature	-40...+60 °C
Storage temperature	-40...+85 °C
Relative humidity	5 to 95% (non-condensing)
Vibration test	Acc. to IEC 60068-2-6
Protection class	IP20
Mounting	Din-rail or direct panel mounting
Housing material	UL94V0 Lexan

RJ45 Fieldbus

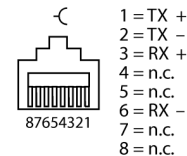

Power Supply

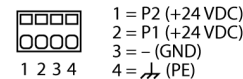

Functional principle

Ethernet switches can be used to simplify Ethernet networks and reduce traffic. They perform an important role in traffic management by forwarding messages only to the port that needs them.

Approvals and certificates	UL508/CSA C22.2/14; EN61010-1; UL1604/CSA C22.2/213 (Class I, Div. 2); EN60079-15 (Zone 2, Category 3); CE (ATEX); IEC60825-1, Class 1; FDA 21 CFR 1040.10 and 1040.11
Life cycle MTBF	>1M Hours GB at 35°C per MIL-HNDBK-217F2