

BS 8151-0/PG9

Actuator and Sensor Field Wireable – M12 Connection

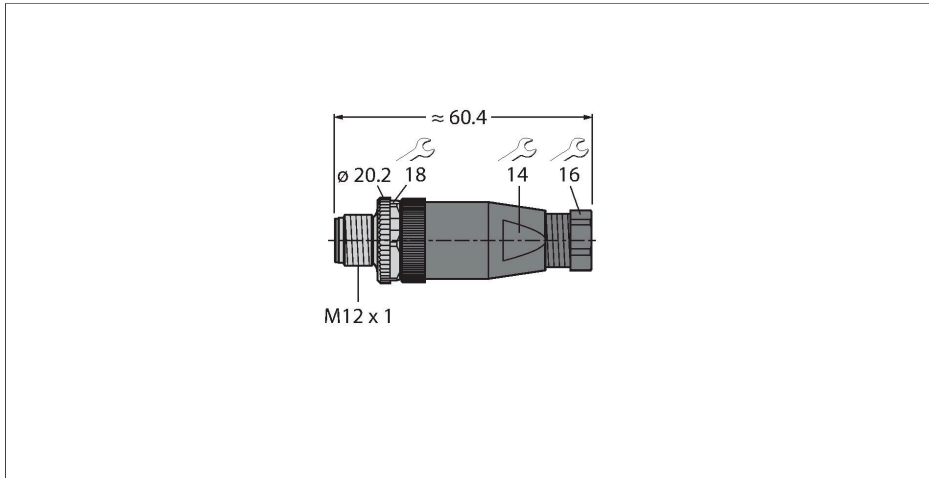

Features



- Zinc-Aluminum coupling nut
- UL approval
- Screw terminal Wire Termination
- Plastic housing
- M12, Male, Straight, 5-pin
- PG9 screw-in thread
- Cable feedthrough 6.0...8.0 mm

Contact assignment

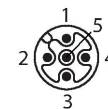

Technische Daten

Type	BS 8151-0/PG9
ID	U6570
Connector A	Male, M12 × 1, Straight, A-code
Number of contacts	5
Contacts	Brass, CuZn, Optalloy Coating
Contact carriers	Plastic, PA, Black
Connector body	Plastic, PA, Black
Coupling nut	Brass, CuZn, Nickel-plated
Acceptable cable diameter	6...8 mm
Core cross-section/Clamping ability	0.14...18 mm ²
Core cross-section/terminal capacity	26...18 AWG
Connection mode	Screw/clamp connection
Mechanical life	> 50 Mating cycles
Pollution degree	3
Protection class (When coupled)	IP67, (screwed together)
Cable data	
Electrical properties at +20 °C	
Rated voltage	250 V
Current	4 A
Mechanical and chemical properties	
Ambient temperature range (static)	-40...+85 °C
Approvals	UL Recognized RoHS

Technische Daten

Note

- We reserve the right to make technical alterations without prior notice.
