

Your Global Automation Partner

TURCK

BEEP

Reference Manual

555T00129
1117A

1	General Information	4
1.1	About these instructions	4
1.2	Explanation of symbols used	4
1.2.1	Warnings	4
1.3	Contents	5
1.3.1	Hardware	5
1.3.2	Software	5
1.4	Feedback about these instructions	5
1.5	Technical support	5
2	Introduction	6
2.1	What is BEEP?	6
2.2	BEEP Advantages	6
2.3	BEEP Limitations	6
3	Getting Started	7
3.1	BEEP Line Topology Configuration	7
3.2	Alternative Line Topology Configurations	8
3.3	BEEP Masters	9
3.4	BEEP Slaves	9
4	Explaining the Webserver – BEEP Master	11
4.1	Logging into the BEEP Master	11
4.2	Navigation Menu	11
4.2.1	BEEP Network Configuration	11
4.2.1.1	BEEP Network Configuration Functions	11
4.2.2	Device information	11
4.2.3	Node Parameters	12
4.2.3.1	Failsafe Mode Configuration	12
5	Configuring the BEEP Master – Ethernet/IP	14
5.1	Logging into the BEEP Master	14
5.2	BEEP Network Configuration	14
5.3	Enable Master	14
5.4	Discover/Update Network	14
5.5	Ethernet/IP Memory Map	15
5.6	Connecting to Allen Bradley PLC via RSLogix	15
6	Configuring the BEEP Master – Modbus TCP/IP	17
6.1	Logging into the BEEP Master	17
6.2	BEEP Network Configuration	17
6.3	Enable Master	17
6.4	Discover/Update Network	17

6.5	Modbus TCP Memory Map	18
6.6	Connecting to Turck HMI/PLC via CODESYS 3	18
7	Configuring the BEEP Master – ProfiNet	20
7.1	Logging into the BEEP Master	20
7.2	BEEP Network Configuration	20
7.3	Enable Master	20
7.4	Discover/Update Network	20
7.5	ProfiNet Memory Map	21
7.6	Connecting to SIEMANS PLC via TIA Portal Version 13	21
8	Device Replacement	23
8.1	Slave Device Replacement	23

1 General Information

1.1 About these instructions

The following user manual describes the setup, functions, and use of the system. It helps you to plan, design, and implement the system for its intended purpose.

Note*: Please read this manual carefully before using the system. This will prevent the risk of personal injury or damage to property or equipment. Keep this manual safe during the service life of the system. If the system is passed on, be sure to transfer this manual to the new owner as well.

1.2 Explanation of symbols used

1.2.1 Warnings

Action-related warnings are placed next to potentially dangerous work steps and are marked by graphic symbols. Each warning is initiated by a warning sign and a signal word that expresses the gravity of the danger. The warnings have absolutely to be observed:



DANGER!

DANGER indicates an immediately dangerous situation, with high risk, the death or severe injury, if not avoided.



WARNING!

WARNING indicates a potentially dangerous situation with medium risk, the death or severe injury, if not avoided.



ATTENTION!

ATTENTION indicates a situation that may lead to property damage, if it is not avoid-ed.



NOTE

In NOTES you find tips, recommendations and important information. The notes facilitate work, provide more information on specific actions and help to avoid overtime by not following the correct procedure.

➤ **CALL TO ACTION**

This symbol identifies steps that the user has to perform.

➔ **RESULTS OF ACTION**

This symbol identifies relevant results of steps

1.3 Contents

1.3.1 Hardware

- TBEN-S1-8DXP
- Compact Logix L16ER
- SIEMENS S7-1200
- Turck TX507 HMI

1.3.2 Software

- BEEP Webserver
- Studio 5000, Version 28
- TIA Portal, Version 14
- CoDeSys Version 3.5

1.4 Feedback about these instructions

We make every effort to ensure that these instructions are as informative and as clear as possible. If you have any suggestions for improving the design or if some information is missing in the document, please send your suggestions to techdoc@turck.com.

1.5 Technical support

For additional support, email inquiries to appsupport@turck.com, or call Application Support at 763-553-7300, Monday-Friday 8AM-5PM CST.

2 Introduction

- What is BEEP?
- What are BEEP's advantages and limitations?

2.1 What is BEEP?

BEEP (Backplane Ethernet Extension Protocol) is a new technology that has been added to many Turck Multiprotocol digital block I/O modules. BEEP allows a network, of up to 33 devices (1 Master + 32 Slaves) or 480 bytes of data, to appear to the PLC as a single device on a single connection using a single IP Address.

2.2 BEEP Advantages

- Consolidation of IP addressing — BEEP allows a network, of up to 33 devices (1 Master + 32 Slaves) or 480 bytes of data, to appear to the PLC as a single device on a single connection using a single IP Address.
- Less downtime — BEEP supports drop-in replacement of slave devices.
- Cost savings — BEEP allows the user an opportunity to invest in a lower cost PLC that supports less connections.
- Unique selling point — BEEP works with standard Ethernet components and requires no special equipment.
- Unique selling point — BEEP is available to the user at no additional cost. It is up to the user if they want to use BEEP or not.

2.3 BEEP Limitations

- Network topology — BEEP must be setup in a line topology. BEEP does not support DLR or ring configuration.
- Localized addressing— BEEP Master device communicates exclusively with slaves. The PLC will not see the slave devices at all.

3 Getting Started

A **BEEP** network consists of one master and at least one slave device. A BEEP master must be assigned a static IP address, while the BEEP slave devices must be set to DHCP mode and have no IP address assigned.

3.1 BEEP Line Topology Configuration

The following line topology must be observed:

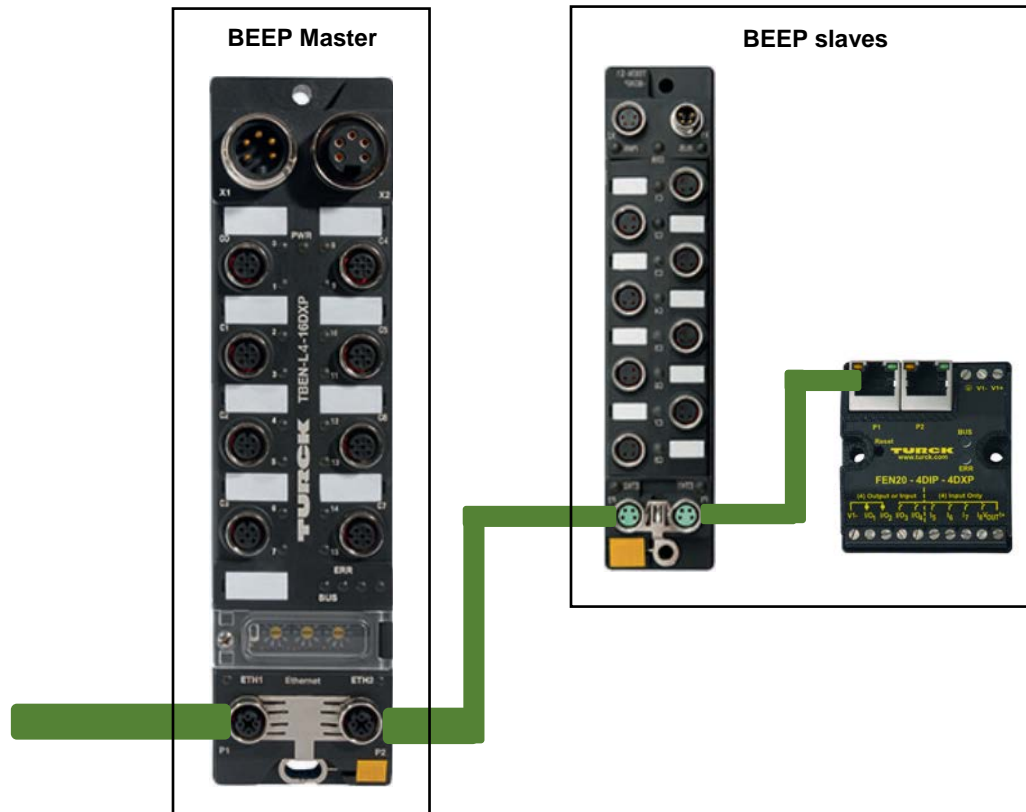

NOTES

- For available list of BEEP master devices see [Section 3.2](#)
- For available list of BEEP slave devices see [Section 3.3](#)
- **Port 2** on the BEEP master must go to **Port 1** on the first BEEP slave.
- BEEP does not work in a ring or DLR configuration.

3.2 Alternative Line Topology Configurations

A line topology using a BEEP master and a competitor device.

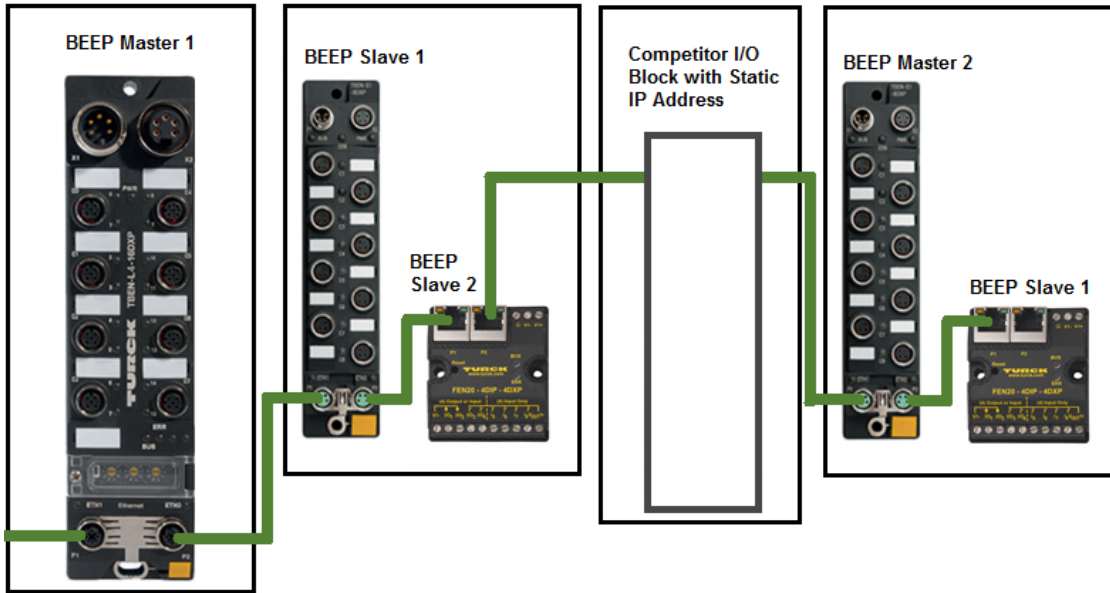

NOTES

- The BEEP master ignores competitor devices that are scattered throughout the line topology.
- The BEEP master is just looking for Turck devices that are in DHCP mode.

A line topology using multiple BEEP masters.

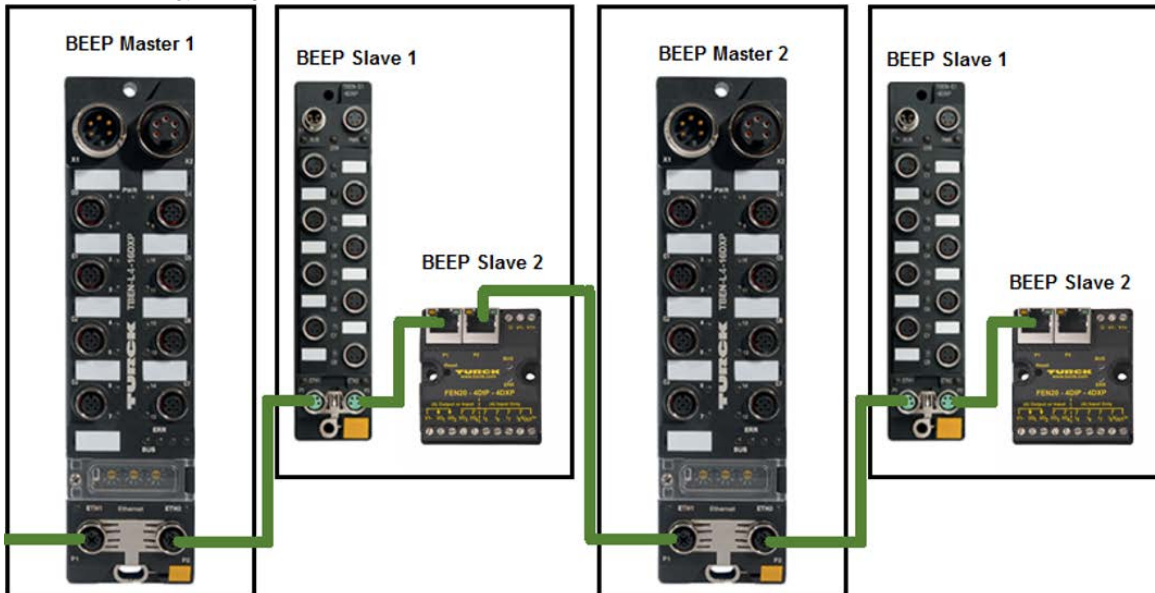

3.3 BEEP Masters

The following devices are BEEP Master capable:

- M6814009 TBEN-L4-16DIP
- 6814011 TBEN-L4-16DOP
- M6814012 TBEN-L4-16DXP
- 6814010 TBEN-L4-8DIP-8DOP
- 6814061 TBEN-L4-16DIN
- 6814063 TBEN-L4-16DON
- 6814064 TBEN-L4-16DXN
- 6814085 TBEN-L5-16DIP
- 6814087 TBEN-L5-16DOP
- 6814088 TBEN-L5-16DXP
- 6814086 TBEN-L5-8DIP-8DOP
- M6814020 TBEN-S1-8DIP
- M6814034 TBEN-S1-8DIP-D
- 6814022 TBEN-S1-8DOP
- M6814023 TBEN-S1-8DXP
- M6814021 TBEN-S1-4DIP-4DOP
- 6814073 TBEN-S2-8DIP
- 6814076 TBEN-S2-8DXP
- F6931090 FEN20-4DIP-4DXP
- 6814129 FEN20-4DIN-4DXN
- 6811493 BLCEN-8PBLT



NOTE

- A BEEP master must have a static IP Address.
- All slave I/O data is mapped inside the webserver of the BEEP master.

3.4 BEEP Slaves

The following devices are BEEP slave capable:

- M6814009 TBEN-L4-16DIP
- 6814011 TBEN-L4-16DOP
- M6814012 TBEN-L4-16DXP
- 6814010 TBEN-L4-8DIP-8DOP
- 6814061 TBEN-L4-16DIN
- 6814063 TBEN-L4-16DON
- 6814064 TBEN-L4-16DXN

- 6814085 TBEN-L5-16DIP
 - 6814087 TBEN-L5-16DOP
 - 6814088 TBEN-L5-16DXP
 - 6814086 TBEN-L5-8DIP-8DOP
 - M6814020 TBEN-S1-8DIP
 - M6814034 TBEN-S1-8DIP-D
 - 6814022 TBEN-S1-8DOP
 - M6814023 TBEN-S1-8DXP
 - M6814021 TBEN-S1-4DIP-4DOP
 - 6814073 TBEN-S2-8DIP
 - 6814076 TBEN-S2-8DXP
 - F6931090 FEN20-4DIP-4DXP
 - 6814129 FEN20-4DIN-4DXN
 - 6811493 BLCEN-8PBLT
-



NOTE

- BEEP slaves must be in DHCP mode
 - BEEP slave capable devices come configured in DHCP mode out of box. If a slave device needs to be put back in DHCP mode, this can be accomplished by doing a factory reset from the device webserver or using Turck Service Tool.
-

4 Explaining the Webserver – BEEP Master

4.1 Logging into the BEEP Master

- Log into the webserver to access BEEP functionality



NOTE

- You must log into the Webserver to access the BEEP Network Configuration.
- The default password for the webserver is “password”.

4.2 Navigation Menu

4.2.1 BEEP Network Configuration

- Select **BEEP Network Configuration**, to start configuration process

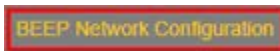

- Select **Enable Master**, to enable BEEP master.



4.2.1.1 BEEP Network Configuration Functions

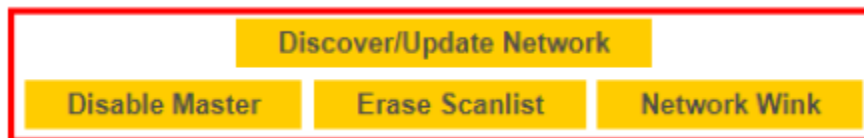

- **Discover/Update Network:** Used to discover a new network or update a network.
- **Disable Master:** Used to disable the Master functionality.
- **Erase Scanlist:** Clear the BEEP Master Scanlist.
- **Network Wink:** Master and all slaves will have Wink or BUS LED flash. Click to turn on Wink function, click again to turn off Wink function.

4.2.2 Device information

- In the grey table of contents, select **Device Information**.





NOTE

The device used in this example was a TBEN-S1-8DXP. The user may see different product numbers depending on what product they are using.

➔ You should see the following:

Master Device Information	
Master description	TBEN-S1-8DXP
MAC address	00:07:46:02:96:9C
Order number	6814023
Version number	V3.3.4.0
IO mode	Simple

4.2.3 Node Parameters

➤ In the grey table of contents, select **Node Parameters**

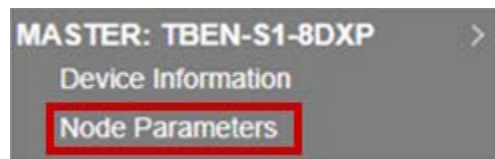

4.2.3.1 Failsafe Mode Configuration

Failsafe Mode Configuration determines how the I/O will respond during a loss of the fieldbus connection.

Node Parameters

Failsafe Mode Configuration	
Master: TBEN-S1-8DXP	<div style="border: 1px solid #ccc; padding: 2px; display: inline-block;"> set outputs to 0 ▼ </div>
<div style="background-color: #FFD700; padding: 5px 15px; display: inline-block; border: 1px solid #ccc;">Submit</div>	<div style="border: 1px solid #ccc; padding: 2px; display: inline-block; background-color: #ADD8E6;"> set outputs to 0 </div> <div style="border: 1px solid #ccc; padding: 2px; display: inline-block; margin-top: 2px;"> substitute value </div> <div style="border: 1px solid #ccc; padding: 2px; display: inline-block; margin-top: 2px;"> hold current value </div>

- **Set outputs to 0:** Outputs are set to zero with loss of fieldbus connection.
- **Substitute value:** Use a substitute value when fieldbus connection is lost.
- **Hold current value:** Holds the current value of the output when fieldbus connection is lost.

- Select the desired I/O condition for each device, then click **Submit**

Node Parameters

Failsafe Mode Configuration	
Master: TBEN-S1-8DXP	hold current value ▼
<input type="button" value="Submit"/> <input type="button" value="Reset"/>	

**NOTE**

- Selecting **Reset** will reset the dropdown menus to their default values.
 - BEEP Masters and Slaves can each have their own individual Failsafe Mode Configuration.
-

5 Configuring the BEEP Master – Ethernet/IP

5.1 Logging into the BEEP Master

- Log into the webserver to access BEEP functionality.



NOTE

The default password for the webserver is “password”.

5.2 BEEP Network Configuration

- Click on BEEP Network Configuration.

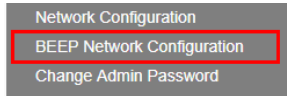

5.3 Enable Master

- Click Enable Master.

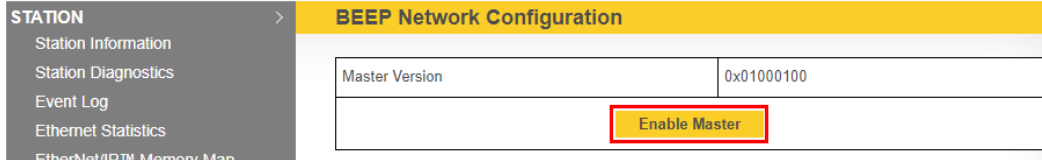

5.4 Discover/Update Network

- Click Discover/Update Network to scan for slaves.

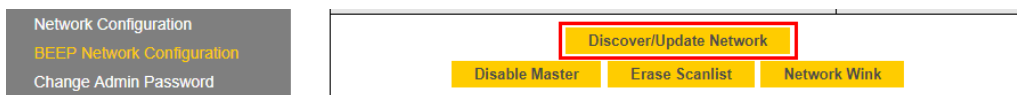

5.5 Ethernet/IP Memory Map

- Click Ethernet/IP Memory Map to see the Assemble Instance and Size of the BEEP network.

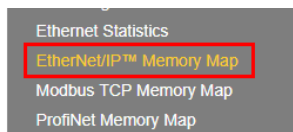

Connection	Assembly Instance	Size (in words)
Input	101	11
Output	112	2



NOTE

- Notice the webserver is updated with a new I/O data map which includes all slave devices.
- Notice the new input connection point: Input Assembly: 101 (0x65), Size: 11 (words)
- Notice the new output connection point: Output Assembly: 112 (0x70), Size: 2 (words)

5.6 Connecting to Allen Bradley PLC via RSLogix

- Create a Generic Ethernet Module in RSLogix.

New Module

Type: ETHERNET-MODULE Generic Ethernet Module
 Vendor: Allen-Bradley
 Parent: Local
 Name: TBEN_BEEP
 Description: BEEP Master
 Comm Format: Data - INT
 Address / Host Name
 IP Address: 192 . 168 . 1 . 124
 Host Name:
 Connection Parameters
 Input: Assembly Instance: 101, Size: 11 (16-bit)
 Output: Assembly Instance: 112, Size: 2 (16-bit)
 Configuration: Assembly Instance: 1, Size: 0 (8-bit)
 Status Input:
 Status Output:
 Open Module Properties
 OK Cancel Help



NOTE

- Due to all the BEEP network configuration being done in the webserver of the BEEP master, the Configuration Assemble Instance can be set to 1 and the Size can be set to 0.

- Use Ethernet/IP Memory Map from webserver to identify tags in RSLogix.

The screenshot shows the RSLogix 5000 Controller Tags window. The main window title is "Controller Tags - BEEP_project1(controller)". The left pane shows the "BEEP Master: TBEN-S1-8DXP Slot 1: Basic (Input Data Mapping)". The main table displays the memory map with columns: Description, Word Offset, Bit Offset, Bit Length, Value, Force Mas, Style, Data Type, and Description. A red arrow points to the "Bit Offset" column.

Description	Word Offset	Bit Offset	Bit Length	Value	Force Mas	Style	Data Type	Description
Channel 0 - Input value	9	0	1	EN_BEEP1.Data[0]	0	Decimal	INT	
Channel 1 - Input value	9	1	1	EN_BEEP1.Data[1]	0	Decimal	INT	
Channel 2 - Input value	9	2	1	EN_BEEP1.Data[2]	0	Decimal	INT	
Channel 3 - Input value	9	3	1	EN_BEEP1.Data[3]	0	Decimal	INT	
Channel 4 - Input value	9	4	1	EN_BEEP1.Data[4]	0	Decimal	INT	
Channel 5 - Input value	9	5	1	EN_BEEP1.Data[5]	0	Decimal	INT	
Channel 6 - Input value	9	6	1	EN_BEEP1.Data[6]	0	Decimal	INT	
Channel 7 - Input value	9	7	1	EN_BEEP1.Data[7]	0	Decimal	INT	
Overcurrent VAUX1 Ch0-3	10	0	1	IBEN_BEEP1.Data[9].0	0	Decimal	BOOL	Master Input 0
Overcurrent VAUX2 Ch4-7	10	1	1	IBEN_BEEP1.Data[9].1	0	Decimal	BOOL	Master Input 1
Channel 0 - Overcurrent	10	8	1	IBEN_BEEP1.Data[9].2	0	Decimal	BOOL	Master Input 2
Channel 1 - Overcurrent	10	9	1	IBEN_BEEP1.Data[9].3	0	Decimal	BOOL	Master Input 3
Channel 2 - Overcurrent	10	10	1	IBEN_BEEP1.Data[9].4	0	Decimal	BOOL	Master Input 4
Channel 3 - Overcurrent	10	11	1	IBEN_BEEP1.Data[9].5	0	Decimal	BOOL	Master Input 5
Channel 4 - Overcurrent	10	12	1	IBEN_BEEP1.Data[9].6	0	Decimal	BOOL	Master Input 6
Channel 5 - Overcurrent	10	13	1	IBEN_BEEP1.Data[9].7	0	Decimal	BOOL	Master Input 7
Channel 6 - Overcurrent	10	14	1	IBEN_BEEP1.Data[9].8	0	Decimal	BOOL	
Channel 7 - Overcurrent	10	15	1	IBEN_BEEP1.Data[9].9	0	Decimal	BOOL	
				EN_BEEP1.Data[10]	255	Decimal	INT	
				EN_BEEP1.Data[11]	0	Decimal	INT	

6 Configuring the BEEP Master – Modbus TCP/IP

6.1 Logging into the BEEP Master

- Log into the webserver to access BEEP functionality.



NOTE

The default password for the webserver is “password”.

6.2 BEEP Network Configuration

- Click on BEEP Network Configuration.

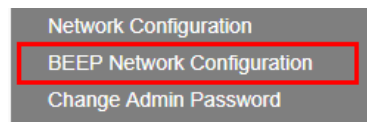

6.3 Enable Master

- Click Enable Master.

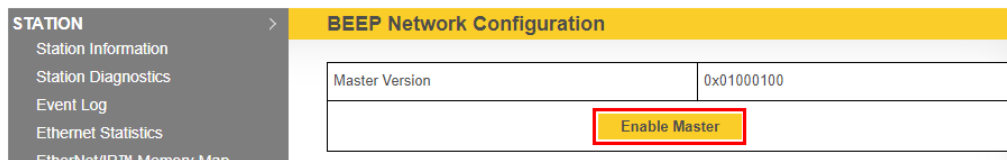

6.4 Discover/Update Network

- Click Discover/Update Network to scan for slaves.

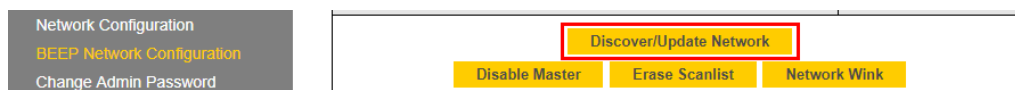

6.5 Modbus TCP Memory Map

- Click on Modbus TCP Memory Map to see the size of the BEEP network.

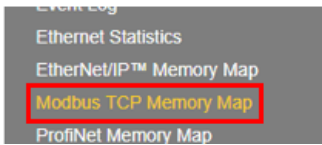

Connection	Size (in words)
Input	11
Output	2



NOTE

- Modbus input registers start at 0x4800 (18432)
- Modbus output registers start at 0x4C04 (19456)

6.6 Connecting to Turck HMI/PLC via CODESYS 3

- Enter IP Address of BEEP Master

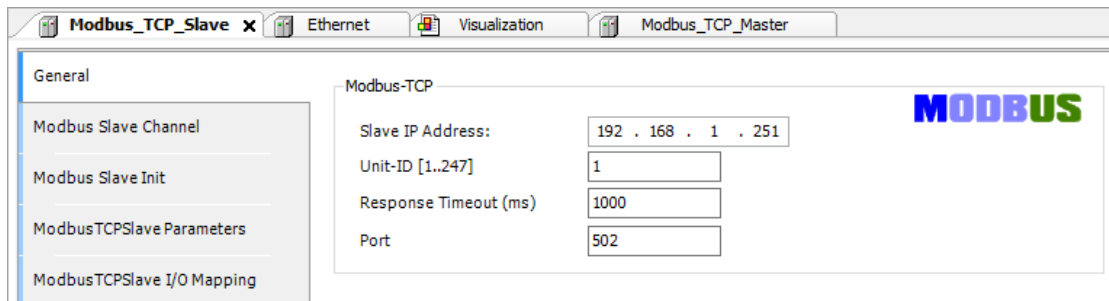

- Enter Read and Write registers and length.

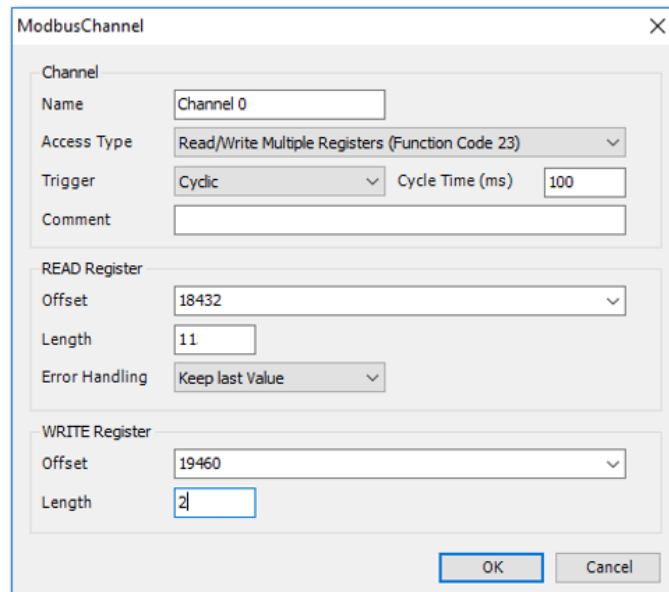

- Use the Modbus TCP Memory Map from webserver to label inputs and outputs in project.

CODESYS

Build Online Debug Tools Window Help

Modbus_TCP_Slave x Ethernet Visualization Modbus_TCP_Master

3CV01)

tion
jePool
ry Manager
PRG (PRG)
Configuration
MainTask
PLC_PRG
VISU_TASK
VisuElems_Visu_Prg
List
alization Manager
TargetVisualization
alization
ernet)
.TCP_Master (Modbus TCP Master)
us_TCP_Slave (Modbus TCP Slave)

BEEP Master: TBEN-S1-8DXP Slot 1: Basic (Input Data Mapping)				Channel	Address	Type	Default Value	Unit	Description
Description	Register	Bit Offset	Bit Length						
Channel 0 - Input value	0x4809 (18441)	0	1	Channel 0[3]	%IW53	WORD			18435:
Channel 1 - Input value	0x4809 (18441)	1	1	Channel 0[4]	%IW54	WORD			18436:
Channel 2 - Input value	0x4809 (18441)	2	1	Channel 0[5]	%IW55	WORD			18437:
Channel 3 - Input value	0x4809 (18441)	3	1	Channel 0[6]	%IW56	WORD			18438:
Channel 4 - Input value	0x4809 (18441)	4	1	Channel 0[7]	%IW57	WORD			18439:
Channel 5 - Input value	0x4809 (18441)	5	1	Channel 0[8]	%IW58	WORD			18440:
Channel 6 - Input value	0x4809 (18441)	6	1	Channel 0[9]	%IW59	WORD			18441:
Channel 7 - Input value	0x4809 (18441)	7	1	Bit0	%IX118.0	BOOL	FALSE		Master Input 0
Overcurrent VAUX1 Ch0-3	0x480A (18442)	0	1	Bit1	%IX118.1	BOOL	FALSE		Master Input 1
Overcurrent VAUX2 Ch4-7	0x480A (18442)	1	1	Bit2	%IX118.2	BOOL	FALSE		Master Input 2
Channel 0 - Overcurrent	0x480A (18442)	8	1	Bit3	%IX118.3	BOOL	FALSE		Master Input 3
Channel 1 - Overcurrent	0x480A (18442)	9	1	Bit4	%IX118.4	BOOL	FALSE		Master Input 4
Channel 2 - Overcurrent	0x480A (18442)	10	1	Bit5	%IX118.5	BOOL	FALSE		Master Input 5
Channel 3 - Overcurrent	0x480A (18442)	11	1	Bit6	%IX118.6	BOOL	FALSE		Master Input 6
Channel 4 - Overcurrent	0x480A (18442)	12	1	Bit7	%IX118.7	BOOL	FALSE		Master Input 7
Channel 5 - Overcurrent	0x480A (18442)	13	1	Bit8	%IX119.0	BOOL	FALSE		
Channel 6 - Overcurrent	0x480A (18442)	14	1	Bit9	%IX119.1	BOOL	FALSE		
Channel 7 - Overcurrent	0x480A (18442)	15	1	Bit10	%IX119.2	BOOL	FALSE		
				Bit11	%IX119.3	BOOL	FALSE		
				Bit12	%IX119.4	BOOL	FALSE		
				Bit13	%IX119.5	BOOL	FALSE		
				Bit14	%IX119.6	BOOL	FALSE		
				Bit15	%IX119.7	BOOL	FALSE		
				Channel 0[10]	%IW60	WORD			18442:
				Channel 0[11]	%IW61	WORD			18443:
				Channel 0[12]	%IW62	WORD			18444:

Reset Mapping Always update variables: Enabled 2 (always in bus cycle task)

Type
ModbusTCPSlave

7 Configuring the BEEP Master – ProfiNet

7.1 Logging into the BEEP Master

- Log into the webserver to access BEEP functionality.



A screenshot of a web interface showing a login form. The word "LOGIN" is written in a small box to the left of a rectangular input field. The entire login area is highlighted with a red and yellow border.



NOTE

The default password for the webserver is “password”.

7.2 BEEP Network Configuration

- Click on BEEP Network Configuration.

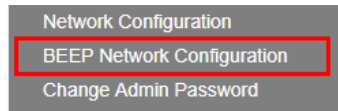

7.3 Enable Master

- Click Enable Master.

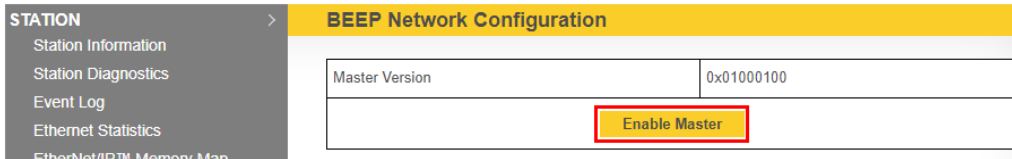

7.4 Discover/Update Network

- Click Discover/Update Network to scan for slaves.

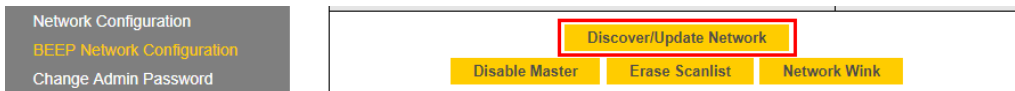

7.5 ProfiNet Memory Map

- Click on ProfiNet Memory Map to see the size of the BEEP network.

STATION

- Station Information
- Station Diagnostics
- Event Log
- Ethernet Statistics
- EtherNet/IP™ Memory Map
- Modbus TCP Memory Map
- ProfiNet Memory Map

ProfiNet Memory Map

Input Data Map | Output Data Map

Connection	BEEP Master Status/Control Data (in bytes)	Process Data (in bytes)
Input	16	24
Output	2	6



NOTE

- ProfiNet integration will have one fully generic GSDML file, which will be the same for all BEEP master nodes
- The BEEP GSDML will provide generic data length modules that can be dragged and dropped in multiple slots.

7.6 Connecting to SIEMANS PLC via TIA Portal Version 13

- In TIA Portal, install BEEP GSDML to update Hardware Catalog.
- Select input and output size from device catalog.

The screenshot shows the 'Device overview' table with the following data:

Module	Rack	Slot	I address	Q address	Type	Article no.
turck-beep-device	0	0			BEEP PN Device	
▶ beep	0	0 X1			turck-beep-device	
BEEP Master Status/Control_1	0	1	256...271	256...263	BEEP Master Status/...	
IN 24 BYTE_1	0	2	68...91		IN 24 BYTE	
OUT 6 BYTE_1	0	3		64...69	OUT 6 BYTE	

The 'Options' panel on the right shows the 'Catalog' with a search bar and a 'Filter' checkbox. Under 'output', various output sizes are listed, including OUT 2 BYTE, OUT 6 BYTE, OUT 12 BYTE, and OUT 192 BYTE.

- In the device properties, select **IP Address is set at the device**.

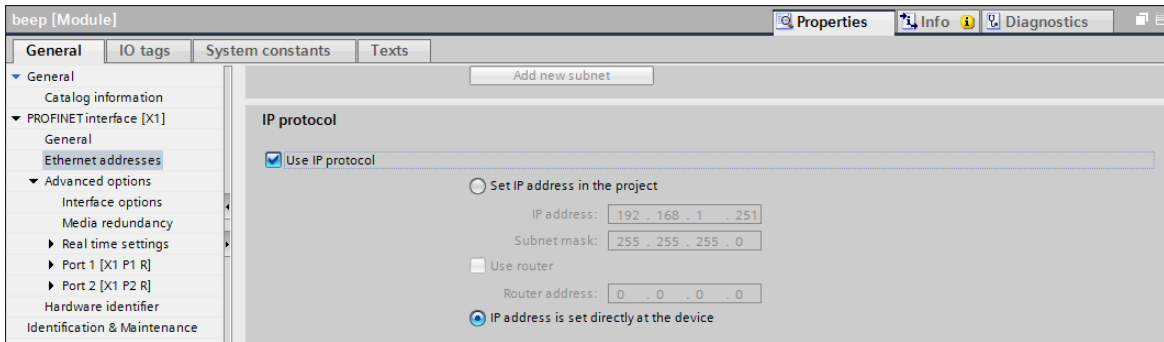

NOTE

DO NOT set or select Set IP Address in the project. The IP Address of the BEEP Master must be set in the webserver only.

8 Device Replacement

8.1 Slave Device Replacement

BEEP supports drop-in replacement of slave devices. If a slave device goes bad, the user will see the following diagnostics message in the webserver:

STATION		Station Diagnostics										
<ul style="list-style-type: none"> Station Information ! Station Diagnostics Event Log Ethernet Statistics EtherNet/IP™ Memory Map Modbus TCP Memory Map 		<table border="1"> <thead> <tr> <th>Device</th> <th>Slot</th> <th>Source</th> <th>Diagnostics</th> </tr> </thead> <tbody> <tr> <td>Master: TBEN-S1-8DXP</td> <td>0</td> <td>Gateway</td> <td> BEEP Status Word: Slave communication lost Diagnostic summary Slave 1 communication lost </td> </tr> </tbody> </table>			Device	Slot	Source	Diagnostics	Master: TBEN-S1-8DXP	0	Gateway	BEEP Status Word: Slave communication lost Diagnostic summary Slave 1 communication lost
Device	Slot	Source	Diagnostics									
Master: TBEN-S1-8DXP	0	Gateway	BEEP Status Word: Slave communication lost Diagnostic summary Slave 1 communication lost									

Simply remove the bad device and replace it with an identical device. The BEEP master will sense the new device and download the parametrization. Station Diagnostics will automatically clear after the device is replaced.



NOTE

- BEEP slaves must be in DHCP mode.
- BEEP slave capable devices come configured in DHCP mode out of box. If a slave device needs to be put back in DHCP mode, this can be accomplished by doing a factory reset from the device webserver or by using the Turck Service Tool.